

HygienicMaster FEH610 Electromagnetic flowmeter

The standard flowmeter:
The clean choice for all hygienic
standard applications.

Measurement made easy



ABB common look and feel

- Easy Set-up function
- Simple and intuitive configuration
- Through-the-glass configuration with capacitive switches
- Backlit, rotatable LCD display
- Configurable display pages

SensorApplicationMemory

- Secure storage of calibration and application specific data
- Quick change-out of transmitter without reprogramming

Verification und Online Diagnostic

- Easy to check based on Fingerprint Technology - the reference signature of the device
- Service Interval Monitoring. Message at end of service interval
- Function and Simulation routines for all outputs

Easy-to-understand diagnostic messages

- Continuous monitoring of sensor and transmitter integrity and process conditions
- Text in help menu in response to diagnostic results for fast and efficient error handling

One single transmitter fits all design types

- Integral mount design or remote mount design
- With or without LCD display
- Universal wide-range power supply

Easily customizable output signals

- Analog current output
- Two fully configurable digital outputs

Ideally suited for hygienic applications

- Field-proven, versatile sensor design
- Modular sensor design with uniform flowmeter body for simplified spare parts
- Variable connection concept
- Wide variety of industry specific process connections
- Worldwide hygienic & food approvals 3A
- FDA approved materials
- Hermetically sealed sensor - optimal Protection against Condensation, vibration and corrosion
- Smallest outer dimensions

Simplified Spare Parts Handling

- Common transmitter electronic results in significant cost reduction
- Simplified stock keeping

HygienicMaster FEH610

Electromagnetic flowmeter

The Company

ABB is an established world force in the design and manufacture of instrumentation for industrial process control, flow measurement, gas and liquid analysis and environmental applications. As a world leader in process automation technology our worldwide presence, comprehensive service and application oriented know-how make ABB a leading supplier of flow measurement products.

Introduction

The industrial standard

HygienicMaster is designed specifically to meet the requirements of the food and beverages and the pharmaceutical industries. The modular design concept offers flexibility, cost-saving operation and reliability whilst providing a long service life and exceptionally low maintenance.

Advanced diagnostic functions

The device monitors its integrity and operability continuously. When limits are exceeded, a corresponding alarm is flagged. Critical states are recognized at an early stage allowing to take appropriate measures.

As a result, productivity is increased and downtimes are avoided. The status messages are classified in accordance with the NAMUR recommendations.

In the event of an error, clear text messages appear on the display considerably simplifying and accelerating the troubleshooting procedure. This gives maximum safety for the process.

Superior and reliable sensor

HygienicMaster provides a great deal of flexibility to the users. The variable process connections simplify installation, reduce inventory requirements and lower replacement costs.

The electrodes are embedded into the liner, ensuring a smooth surface without gaps or crevices.

The reinforced PFA liner improves vacuum stability and prevents potential liner deformation. The sensor is fully CIP/SIP cleanable. A large selection of electrode materials, electrode shapes and process connections makes HygienicMaster ideally suited for any process.

HygienicMaster is manufactured from FDA approved materials and certified in accordance with 3A.

Intuitive, convenient navigation

The user-friendly interface allows quick and simple data entry for all process parameters.

“Easy Set-up” guides the operator step by step through the menu to set parameters as fast as possible. During configuration, the limit of each parameter is indicated on the display and invalid configurations rejected.

HygienicMaster is manufactured from FDA approved materials and certified in accordance with 3A.

Universal transmitter - powerful and flexible

All product versions utilize a common electronic to lower inventory costs and spare parts.

This same cartridge can be deployed in integral and remote installations and features current, status and pulsed outputs.

The backlit, graphical display can be easily rotated through 270° allowing field teams to customize the display that best fits their needs.

TTG (Through-the-glass) operation allows local operator interface to input short, quick data for all user specific parameters.

The universal ABB Human Machine Interface (HMI) simplifies operation, maintenance and training; thereby reducing cost of ownership and providing one common user experience.

Overview – models

Integral mount design



Remote mount design

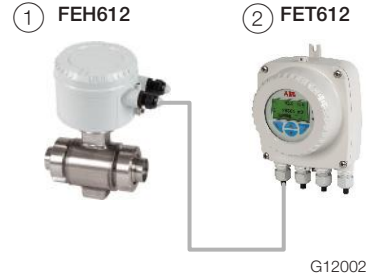

Fig. 1: Designs

① Flowmeter sensor ② Remote transmitter

Flowmeter sensor	
Model	HygienicMaster FEH611, FEH612
Housing	Integral mount design, remote mount design
Measuring accuracy for liquids	0.5 % of measured value
Permissible measuring medium temperature T_{medium}	-25 ... 130 °C (-13 ... 266 °F)
Minimum conductivity	> 20 µS/cm (20 µS/cm for demineralized water)
Nominal pressure	PN 10 ... 40, ASME CL 150, 300, JIS 10K
Nominal diameter	DN 3 ... 100 (1/10 " ... 4 ")
Process connection	Wafer type design: DN 3 ... 100 (1/10 ... 4") Flange in acc. with DIN, ASME or JIS: DN 3 ... 100 (1/10 ... 4"), PN 10 ... 40 Threaded pipe connection in acc. with DIN 11851 ¹⁾ : DN 3 ... 100 (1/10 ... 4"), PN 10 ... 40 Weld stubs ¹⁾ : DN 3 ... 100 (1/10 ... 4"), PN 10 ... 40 Tri-Clamp in acc. with DIN 32676 ¹⁾ : DN 3 ... 100 (1/10 ... 4"), PN 10 ... 16 Tri-Clamp in acc. with ASME BPE ¹⁾ : DN 3 ... 100 (1/10 ... 4"), PN 10 External thread in acc. with ISO 228 / DIN 2999: DN 3 ... 25 (1/10 ... 1"), PN 16
Process connection material	Stainless steel
Liner material	PFA (vakuum tight)
Electrode material	CrNi steel 1.4571 (AISI 316Ti), 1.4539 [904L], Hastelloy B, Hastelloy C, platinum-iridium, tantalum, titanium
IP rating	Integral mount design: IP 65 / IP 67 Remote mount design: IP 65 / IP 67 / IP 68 (sensor only)

Approvals

Pressure Equipment Directive 2014/68/EU	Conformity assessment in accordance with category III, fluid group 1
CRN (Canadian Reg.Number)	On request
Hygienic design approvals	3A, FDA-approved materials
Further approvals	At www.abb.com/flow or on request.

1) 3A approved

HygienicMaster FEH610

Electromagnetic flowmeter

Transmitter	
Model	FET612
Housing	Integral mount design (see Fig. 1), remote mount design.
IP rating	IP 65 / IP 67
Cable length	Maximum 50 m (164 ft), remote mount design only
Power supply	100 ... 240 V AC (-15 / +10 %), 24 ... 48 V DC (-10% / +10 %)
Outputs	Current output: 4 ... 20 mA, active Digital output 1: passive, configurable as pulse, frequency or switch output Digital output 2: passive, configurable as pulse or switch output
Local display	Configurable graphical display (option)
Approvals	
— Further approvals	At www.abb.com/flow or on request.

Measuring principle

Measurements performed by the electromagnetic flowmeter are based on Faraday's law of induction. A voltage is generated in a conductor when it moves through a magnetic field.

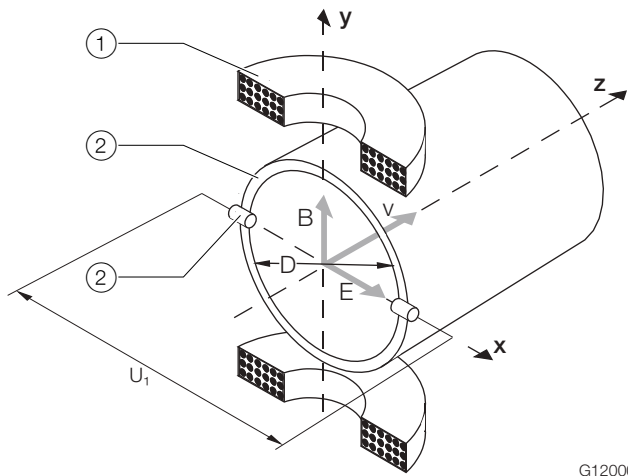

G12000

Fig. 2: Electromagnetic flowmeter schematic

① Magnet coil ② Measuring tube in electrode plane ③ Signal electrode

$$U_1 \sim B \times D \times v \quad qv = \frac{D^2 \times \pi}{4} \times v \quad U_1 \sim qv$$

U_1 Signal voltage v Average flow velocity
 B Magnetic induction qv Volume flow
 D Electrode spacing

This principle is applied to a conductive fluid in the measuring tube through which a magnetic field is generated perpendicular to the flow direction (see Fig. 2). The voltage induced in the fluid is measured by two electrodes located diametrically opposite each other. This signal voltage is proportional to the magnetic induction, the electrode spacing and the average flow velocity. Considering that the magnetic induction and the electrode spacing are constant values, a proportionality exists between the signal voltage U_E and the average flow velocity. From the equation for calculating the volume flowrate, it follows that the signal voltage is linearly proportional to the volume flowrate. The induced voltage is converted by the transmitter to standardized, analog and digital signals.

Flowmeter sensor

Measuring accuracy Reference conditions

According to EN 29104

Measuring medium temperature	20 °C (68 °F) ±2 K
Ambient temperature	20 °C (68 °F) ±2 K
Power supply	Nominal voltage acc. to name plate U = ±1 %, Frequency f = ±1 %
Installation condition	– Upstream >10 x DN, straight section – Downstream >5 x DN, straight section
Warm-up phase	30 min

Measuring error and repeatability Measuring error

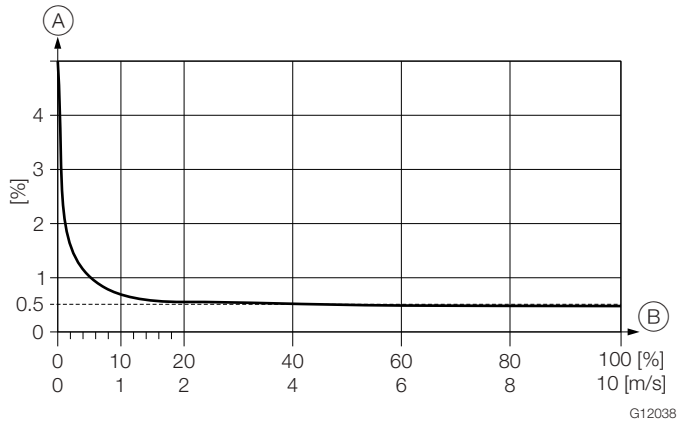

Fig. 3: Measuring error

- (A) Accuracy ± of measured value in %
- (B) Flow velocity v in m/s, Q / Q_{maxDN} in %

Impulse output

±0.5 % of measured value, ±0.02 % Q_{maxDN}¹⁾

1) Q_{maxDN}: See table in chapter "Measuring range table" on page 7.

Current output

Same as pulse output plus ±0.1 % of measured value ±0.01 mA

Repeatability, response time

Repeatability	≤ 0.11 % of measured value, t _{meas} = 100 s, v = 0.5 ... 10 m/s
Response time ¹⁾	As step function 0 ... 99 % 5 τ ≥ 200 ms at 25 Hz excitation frequency 5 τ ≥ 400 ms at 12.5 Hz excitation frequency 5 τ ≥ 500 ms at 6.25 Hz excitation frequency

1) Of current output with damping of 0.02 seconds.

HygienicMaster FEH610

Electromagnetic flowmeter

Permitted pipe vibration

In accordance with EN 60068-2-6.

Applicable to sensors in remote mount design and sensors in integral mount design.

- Maximum deflection: 0.15 mm (0.006 inch) in the 10 ... 58 Hz range
- Maximum acceleration: 2 g, in the 58 ... 150 Hz range

IP rating

- IP 65 / IP 67 in accordance with EN 60529
- IP 68 in accordance with EN 60529 (for remote mount design only)

Signal cables

For remote mount design only.

The maximum signal cable length between flowmeter sensor and transmitter is 50 m (164 ft).

A 5 m (16.4 ft) cable is included in the scope of delivery.

If more than 5 m (16.4 ft) is required, the cable can be ordered separately (Part no. D173D031U01).

Temperature data

The temperature range offered by the device is dependent on a number of different factors.

These factors include the measuring medium temperature T_{medium} , the ambient temperature $T_{\text{amb.}}$, the operating pressure P_{medium} , the liner material and the approvals for the explosion protection.

Storage temperature range

-30 ... 70 °C (-22 ... 158 °F)

Maximum permissible cleaning temperature

CIP medium	Liner material	Cleaning temperature
Steam	PTFE, PFA	150 °C (302 °F)
Cleaning fluid	PTFE, PFA	140 °C (284 °F)

- The specified cleaning temperature applies for a maximum ambient temperature of 25 °C (77 °F).
If the ambient temperature is > 25 °C (> 77 °F), the difference to the actual ambient temperature must be subtracted from the maximum cleaning temperature.
- The specified cleaning temperature may be applied for a maximum of 60 minutes.

Maximum permissible temperature shock

- Maximum temperature shock temperature difference in °C: Any
- Temperature gradient °C/min: Any

Ambient temperature as a function of measuring medium temperature

Process connection	Ambient temperature range ($T_{amb.}$)		Measuring medium temperature range (T_{medium})	
	Minimum	Maximum	Minimum	Maximum ¹⁾
Flange	-20 °C (-4 °F)	60 °C (140 °F)	-25 °C (-13 °F)	95 °C (203 °F)
	-20 °C (-4 °F)	45 °C (113 °F)	-25 °C (-13 °F)	130 °C (266 °F)
Variable process connections	-20 °C (-4 °F)	60 °C (140 °F)	-25 °C (-13 °F)	95 °C (203 °F)
	-20 °C (-4 °F)	45 °C (113 °F)	-25 °C (-13 °F)	130 °C (266 °F)
Flange	-20 °C (-4 °F)	60 °C (140 °F)	-25 °C (-13 °F)	95 °C (203 °F)
	-20 °C (-4 °F)	45 °C (113 °F)	-25 °C (-13 °F)	130 °C (266 °F)
Variable process connections	-20 °C (-4 °F)	60 °C (140 °F)	-25 °C (-13 °F)	95 °C (203 °F)
	-20 °C (-4 °F)	45 °C (113 °F)	-25 °C (-13 °F)	130 °C (266 °F)

1) For CIP/SIP cleaning, higher temperatures are permitted for limited time periods; refer to chapter "Maximum permissible cleaning temperature" on page 6.

Measuring range table

The flow range end value can be set between $0.02 \times Q_{max}DN$ and $2 \times Q_{max}DN$.

Nominal diameter		Minimum flow range end value	$Q_{max}DN$	Maximum flow range end value
DN	inch	$0.02 \times Q_{max}DN$ (≈ 0.2 m/s)	0 ... ≈ 10 m/s	$2 \times Q_{max}DN$ (≈ 20 m/s)
3	1/10	0.08 l/min (0.02 US gal/min)	4 l/min (1.06 US gal/min)	8 l/min (2.11 US gal/min)
4	5/32	0.16 l/min (0.04 US gal/min)	8 l/min (2.11 US gal/min)	16 l/min (4.23 US gal/min)
6	1/4	0.4 l/min (0.11 US gal/min)	20 l/min (5.28 US gal/min)	40 l/min (10.57 US gal/min)
8	5/16	0.6 l/min (0.16 US gal/min)	30 l/min (7.93 US gal/min)	60 l/min (15.85 US gal/min)
10	3/8	0.9 l/min (0.24 US gal/min)	45 l/min (11.9 US gal/min)	90 l/min (23.78 US gal/min)
15	1/2	2 l/min (0.53 US gal/min)	100 l/min (26.4 US gal/min)	200 l/min (52.8 US gal/min)
20	3/4	3 l/min (0.79 US gal/min)	150 l/min (39.6 US gal/min)	300 l/min (79.3 US gal/min)
25	1	4 l/min (1.06 US gal/min)	200 l/min (52.8 US gal/min)	400 l/min (106 US gal/min)
32	1 1/4	8 l/min (2.11 US gal/min)	400 l/min (106 US gal/min)	800 l/min (211 US gal/min)
40	1 1/2	12 l/min (3.17 US gal/min)	600 l/min (159 US gal/min)	1200 l/min (317 US gal/min)
50	2	1.2 m ³ /h (5.28 US gal/min)	60 m ³ /h (264 US gal/min)	120 m ³ /h (528 US gal/min)
65	2 1/2	2.4 m ³ /h (10.57 US gal/min)	120 m ³ /h (528 US gal/min)	240 m ³ /h (1057 US gal/min)
80	3	3.6 m ³ /h (15.9 US gal/min)	180 m ³ /h (793 US gal/min)	360 m ³ /h (1585 US gal/min)
100	4	4.8 m ³ /h (21.1 US gal/min)	240 m ³ /h (1057 US gal/min)	480 m ³ /h (2113 US gal/min)

HygienicMaster FEH610

Electromagnetic flowmeter

Process connections

For an overview of the available process connection variants, see the chapter entitled "Overview – models" on page 3.

Installation length

The flange devices comply with the installation lengths specified in ISO 13359, or according to DVGW (process sheet W420, design WP, ISO 4064 short).

For further details, refer to chapter "Dimensions" on page 16.

Materials

Wetted parts		
Part	Standard	Option
Liner material	PFA	—
Measurement and grounding electrode		
	CrNi steel 1.4539 (AISI 904L)	CrNi steel 1.4571 (AISI 316Ti), Hastelloy C-4 (2.4610), Hastelloy B-3 (2.4600), Titanium, tantalum, Platinum-iridium
Gaskets (for Weld stubs, threaded connection, Tri-Clamp, external threads)		
	EPDM (Ethylene-Propylene) with FDA approval, silicone with FDA approval (CIP-resistant, no oils or grease)	Silicone with FDA approval (option, oil or grease resistant) PTFE with FDA approval (DN 3 ... 8)
Process connection		
Welded spuds, Tri-Clamp, etc.	CrNi steel 1.4404 (AISI 316L)	—
OD tubing	CrNi steel 1.4435 (AISI 316L)	—

Non-wetted parts (process connection)

Part	Standard	Option
Process connection	CrNi steel 1.4571 (AISI 316Ti)	—

Sensor housing

Part	Material
Housing	Deep-drawn housing CrNi steel 1.4301 (AISI 304), 1.4308
Meter tube	Stainless steel
Terminal box	Plastic, gray white, RAL 9002
Cable gland ¹⁾	Polyamide

1) Cable gland with M 20 x 1.5 or NPT thread, to be selected via the order number.

Material loads for process connections

The limits for the permissible measuring medium temperature (T_{medium}) and permissible pressure (P_{medium}) are calculated on the basis of the lining and flange material used in the device (refer to the name plate on the device).

Minimum permissible operating pressure

The following tables show the minimum permissible operating pressure (P_{medium}) depending on measuring medium temperature (T_{medium}) and the liner material.

Liner material	Nominal diameter	P_{medium} [mbar abs]	T_{medium} ¹⁾
PFA	DN 3 ... 100 (1/10 ... 4")	0	< 130 °C (266 °F)

1) For CIP/SIP cleaning, higher temperatures are permitted for limited time periods; refer to the chapter "Maximum permissible cleaning temperature" on page 6.

Liner approvals on request; please contact ABB.

Overview - Material load

Process connection	DN	P _{medium max.}	T _{medium}
Wafer type	DN 3 ... 50 (1/10 ... 2")	40 bar (580 psi)	-25 ... 130 °C (-13 ... 266 °F)
	DN 65 ... 100 (2 1/2 ... 4")	16 bar (232 psi)	
Welded spuds DIN 2463, ISO 1127, DIN 11850	DN 3 ... 40 (1/10 ... 1 1/2")	40 bar (580 psi)	-25 ... 130 °C (-13 ... 266 °F)
	DN 50, DN 80 (2", 3")	16 bar (232 psi)	
	DN 65, DN 100 (2 1/2", 4")	10 bar (145 psi)	
Welded spuds SMS 1145	DN 25, DN 40 ... 100 (1", 1.5 ... 4")	6 bar (87 psi)	-25 ... 130 °C (-13 ... 266 °F)
Threaded pipe connection DIN 11851	DN 3 ... 40 (1/10 ... 1 1/2")	40 bar (580 psi)	-25 ... 130 °C (-13 ... 266 °F)
	DN 50, DN 80 (2", 3")	16 bar (232 psi)	
	DN 65, DN 100 (2 1/2", 4")	10 bar (145 psi)	
Tri-Clamp DIN 32676	DN 3 ... 50 (1/10 ... 2")	16 bar (232 psi)	-25 ... 130 °C (-13 ... 266 °F)
	DN 65 ... 100 (2 1/2 ... 4")	10 bar (145 psi)	
Tri-Clamp ASME BPE	DN 3 ... 80 (1/10 ... 3")	10 bar (145 psi)	-25 ... 121 °C (-13 ... 250 °F)
	DN 100 (4")	8.6 bar (124.7 psi)	
External thread ISO 228, DIN 2999	DN 3 ... 25 (1/10 ... 1")	16 bar (232 psi)	-25 ... 130 °C (-13 ... 266 °F)
Welded spuds OD tubing	DN 3 ... 50 (1/10 ... 2")	10 bar (145 psi)	-25 ... 130 °C (-13 ... 266 °F)

Flange devices

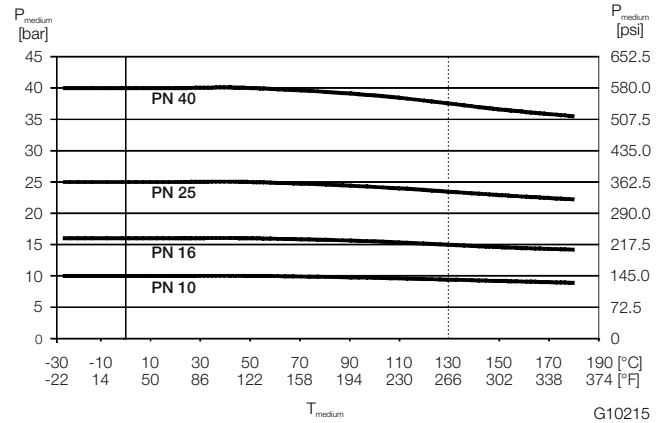

Fig. 4: DIN flange stainless steel to DN 100 (4")

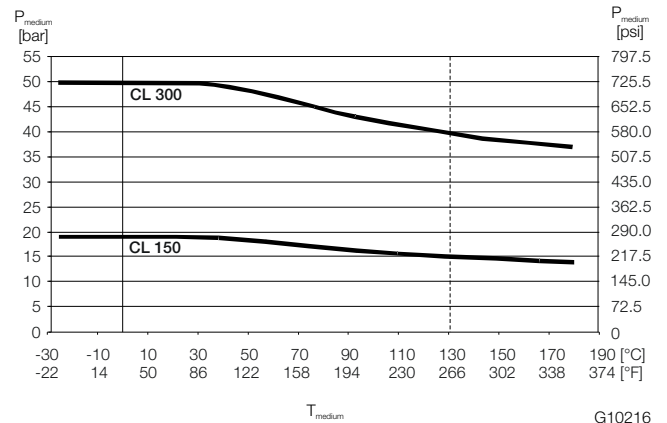

Fig. 5: ASME flange, stainless steel, up to DN 100 (4") (CL 150 / CL 300)

JIS 10K-B2210 flange

DN	Material	PN	T _{medium}	P _{medium}
DN 25 ... 100 (1 ... 4")	Stainless steel	10	-25 ... 130 °C (-13 ... 266 °F)	10 bar (145 psi)

HygienicMaster FEH610

Electromagnetic flowmeter

Wafer type devices

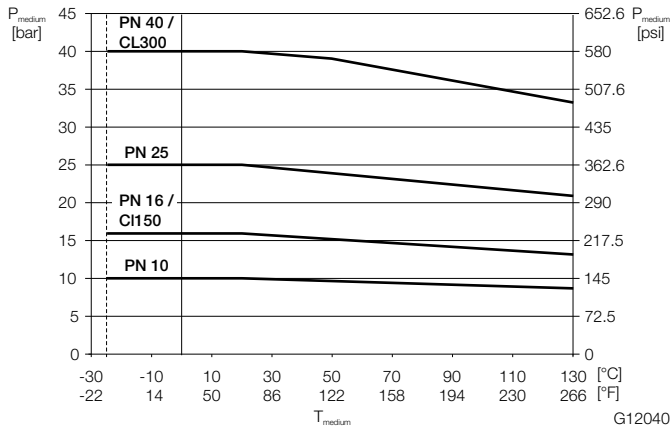

Fig. 6: Wafer type design

JIS 10K-B2210 wafer type design				
DN	Material	PN	T _{medium}	P _{medium}
DN 32 ... 100 (1 1/4 ... 4")	1.4404 1.4435 1.4301	10	-25 ... 130 °C (-13 ... 266 °F)	10 bar (145 psi)

Installation conditions

General information

The following points must be observed during installation:

- The flow direction must correspond to the marking, if present.
- The maximum torque for all flange screws must be complied with.
- Secure the flange bolts and nuts against pipe vibration.
- The devices must be installed without mechanical tension (torsion, bending).
- Install flange devices / wafer-type devices with plane parallel counterflanges and use appropriate gaskets only.
- Only gaskets made from a material that is compatible with the measuring medium and measuring medium temperature may be used.
- Gaskets must not extend into the flow area, since possible turbulence could influence the accuracy of the device.
- The piping may not exert any inadmissible forces or torques on the device.
- Make sure temperature limits are not exceeded operating the device.
- Vacuum shocks in the piping should be avoided to prevent damage to the liners (PTFE). Vacuum shocks can destroy the device.
- Do not remove the sealing plugs in the cable glands until you are ready to install the electrical cable.
- Make sure the gaskets for the housing cover are seated correctly. Carefully gasket the cover. Tighten the cover fittings.
- The transmitter with a remote mount design must be installed at a largely vibration-free location.
- Do not expose the transmitter and sensor to direct sunlight. Provide appropriate sun protection as necessary.
- When installing the transmitter in a control cabinet, make sure adequate cooling is provided.
- In case of a remote mounted transmitter make sure that the sensor and the transmitter have been assigned correctly. Compatible devices have the same end numbers on the name plate, e.g. flowmeter sensor X001 belongs to transmitter Y001 or flowmeter sensor X002 belongs to transmitter Y002.

Gaskets

The following points must be observed when installing gaskets:

- For achieve the best results, ensure the gaskets fit concentrically with the meter tube
- To ensure that the flow profile is not distorted, the gaskets must not protrude into the piping.
- The use of graphite with the flange or process connection gaskets is prohibited, because an electrically conductive coating may form on the inside of the meter tube.

Devices with a PFA liner

- In principle, devices with a PFA liner do not require additional gaskets.

Devices with a wafer-type design

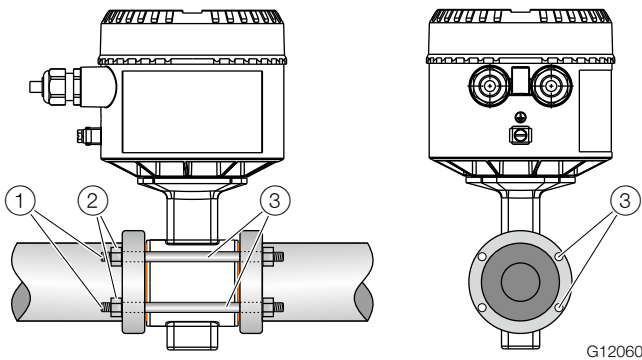

Fig. 7: Installation set for wafer-type installation (example)
① Threaded rod ② Nut with washer ③ Centering sleeves

For devices with a wafer-type design, ABB offers an installation set as an accessory that comprises threaded rods, nuts, washers and centering sleeves for installation.

Flow direction

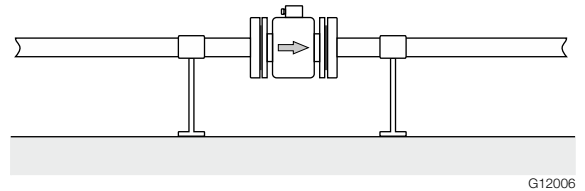

Fig. 8: Flow direction

The device measures the flowrate in both directions. Forward flow is the factory setting, as shown in Fig. 8.

Elektrode axis

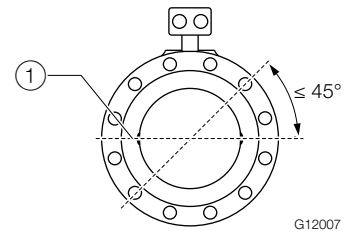

Fig. 9: Orientation of the electrode axis
① Elektrode axis

The electrode axis should be horizontal if at all possible or no more than 45° from horizontal.

HygienicMaster FEH610

Electromagnetic flowmeter

Mounting position

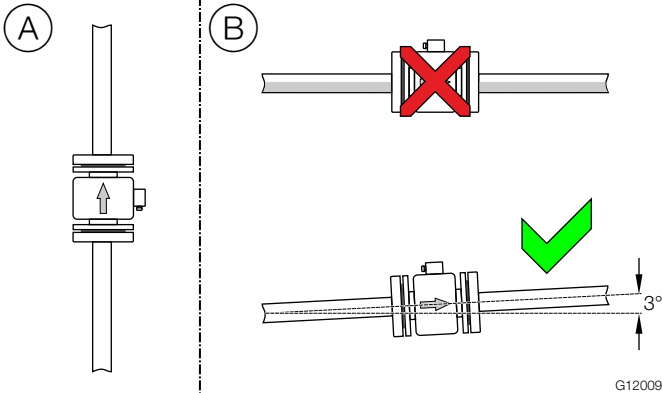

G12009

Fig. 10: Mounting position

- (A) Vertical installation for measuring abrasive fluids, preferably with flow in upward direction.
- (B) In case of horizontal installation, the Meter tube must always be completely full.
Provide for a slight incline of the connection for degassing.

NOTE

Prefer vertical installation in hygienic applications!
With horizontal installation assure the sensor is self-drainable.

Minimum distance

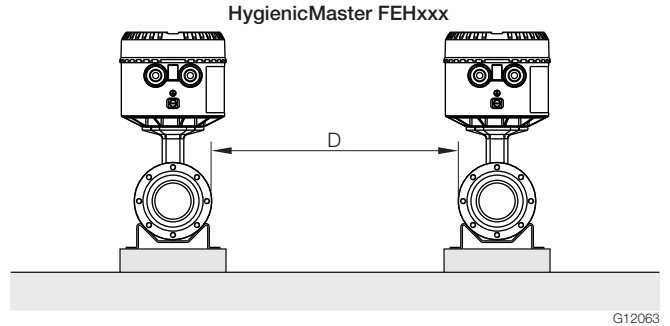

Distance D: $\geq 1.0 \text{ m}$ ($\geq 3.3 \text{ ft}$)

Fig. 11: Minimum distance

- In order to prevent the devices from interfering with each other, a minimum distance as shown in Fig. 11 must be maintained between the devices.
- The flowmeter sensor may not be operated in the vicinity of powerful electromagnetic fields, e.g., motors, pumps, transformers, etc. A minimum spacing of approx. 1 m (3.28 ft) should be maintained.
- For installation on or to steel parts (e.g. steel brackets), a minimum spacing of approx. 100 mm (3.94 inch) should be maintained (based on IEC801-2 and IECTC77B).

Inlet and outlet sections

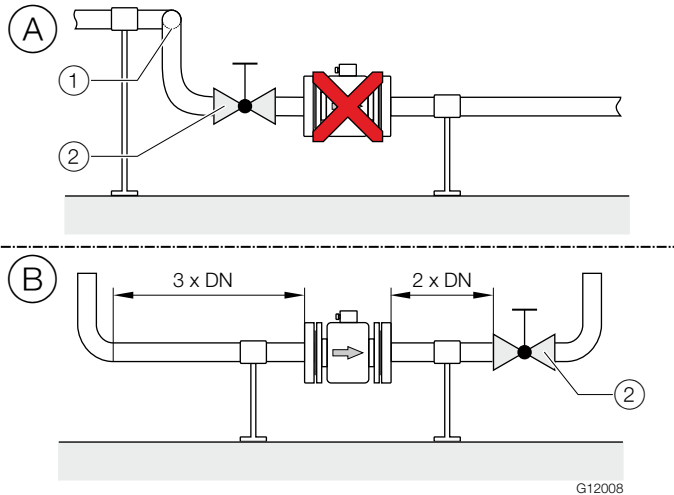

Fig. 12: In- and outlet section, turn-off component
 ① Double elbow ② Turn-off component

The metering principle is independent of the flow profile as long as standing eddies do not extend into the metering section, such as may occur after double elbows, in the event of tangential inflow, or where half-open gate valves are located upstream of the flowmeter sensor.

In such cases, measures must be put in place to normalize the flow profile.

- Ⓐ Do not install fittings, manifolds, valves, etc., directly in front of the flowmeter sensor.
- Ⓑ Inlet and outlet section: Length of straight inlet and outlet section of the flowmeter sensor.

Experience has shown that, in most installations, inlet sections 3 x DN long and outlet sections 2 x DN long are sufficient (DN = nominal diameter of the flowmeter sensor). For test stands, the reference conditions of 10 x DN inlet section and 5 x DN outlet section must be provided, in accordance with EN 29104 / ISO 9104.

Valves or other turn-off components should be installed in the outlet section.

Butterfly valves must be installed so that the valve plate does not extend into the flowmeter sensor.

Free inlet or outlet

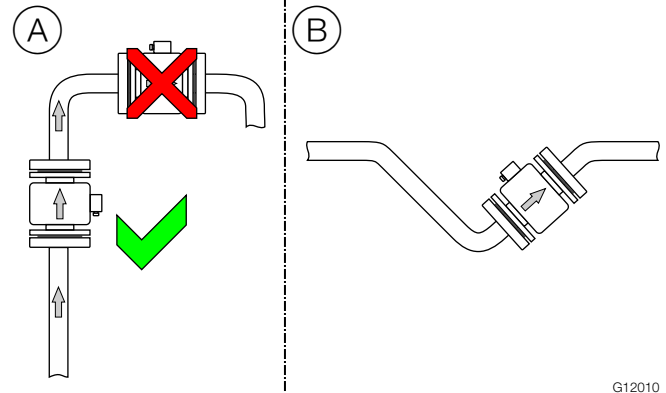

Fig. 13: Free inlet or outlet

- Ⓐ Do not install the flowmeter at the highest point or in the draining off side of the pipeline, flowmeter runs empty, air bubbles can form.
- Ⓑ Provide for a siphon fluid intake for free inlets or outlets so that the pipeline is always full.

Strongly contaminated measuring media

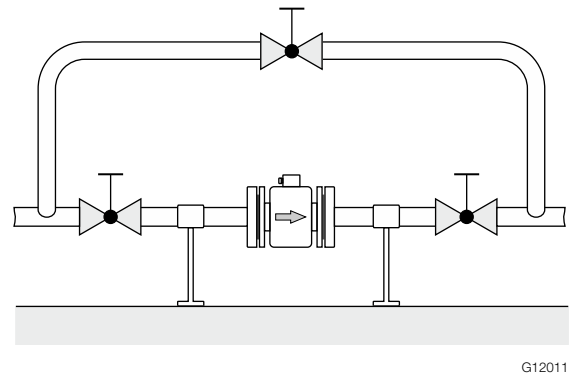

Fig. 14: Bypass connection

For strongly contaminated measuring media, a bypass connection according to the figure is recommended so that operation of the system can continue to run without interruption during the mechanical cleaning.

HygienicMaster FEH610 Electromagnetic flowmeter

Installation in the vicinity of pumps

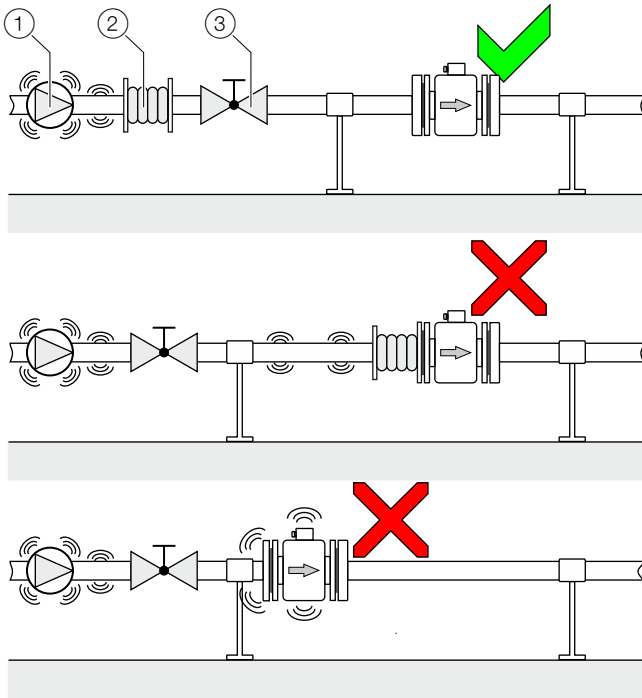

Fig. 15: Vibration damping

① Pump ② Damping device ③ Shut-off device

Strong vibrations in the pipeline must be damped using flexible damping devices.

The damping devices must be installed beyond the supported flowmeter section and outside of the section between the shut-off devices.

Do not connect flexible damping devices directly to the flowmeter sensor.

G12012

Installation in pipelines with larger nominal diameters

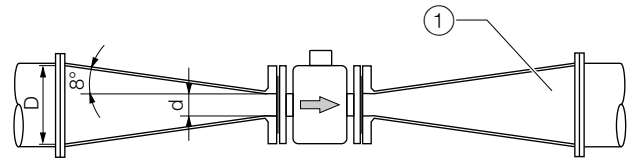

G12014

Fig. 16: using reduction pieces

① Transition piece

Determine the resulting pressure loss when using transition pieces:

1. Calculate the diameter ratio d/D .
2. Determine the flow velocity based on the flow range nomograph (Fig. 17).
3. Read the pressure drop on the Y-axis in Fig. 17.

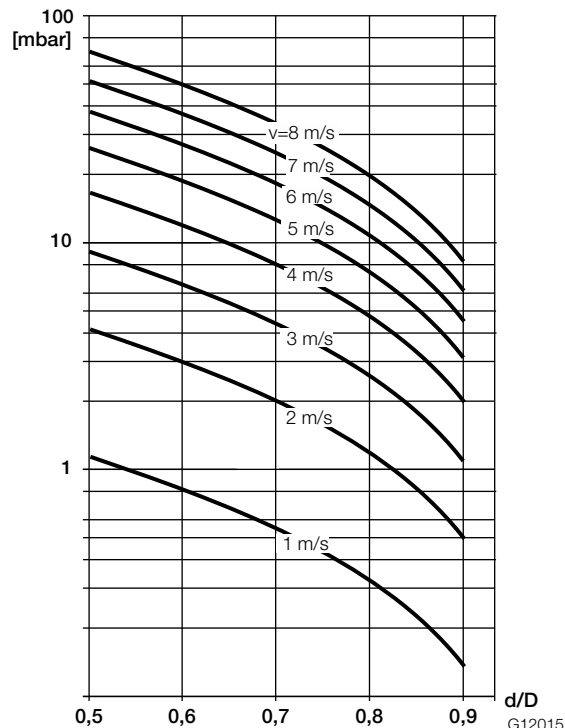

Fig. 17: Nomograph for pressure drop calculations for flange transition piece with $\alpha/2 = 8^\circ$

G12015

Installation in 3A-compliant installations

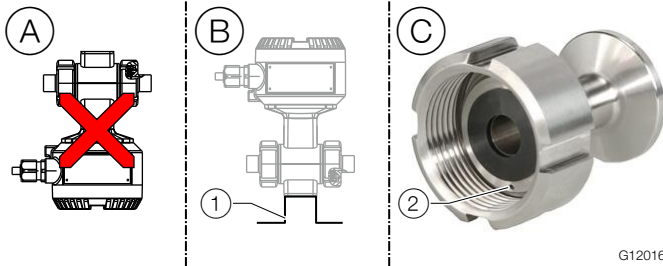

Fig. 18: 3A-compliant installation

① Mounting bracket ② Leakage hole

Please observe the following points:

- Ⓐ Do not install the device horizontally with the terminal box or transmitter housing pointing downward.
- Ⓑ The "mounting bracket" option is not 3A-compliant.
- Ⓒ Please ensure that the leakage hole of the process connection is located at the deepest point of the installed device.
 - Prefer vertical installation. With horizontal installation make sure the sensor is self-drainable
 - Make sure the sensor terminal compartment cover and/or the transmitter housing cover is tightened properly to ensure there is no gap between the base of the housing and the cover.

Only devices with following process connections are 3A-compliant:

- Welded stubs
- Tri-Clamp

HygienicMaster FEH610

Electromagnetic flowmeter

Dimensions

Flange DN 3 ... 100 (1/10 ... 4")

All specified dimensions and weights are in mm (inch) or kg (lb).

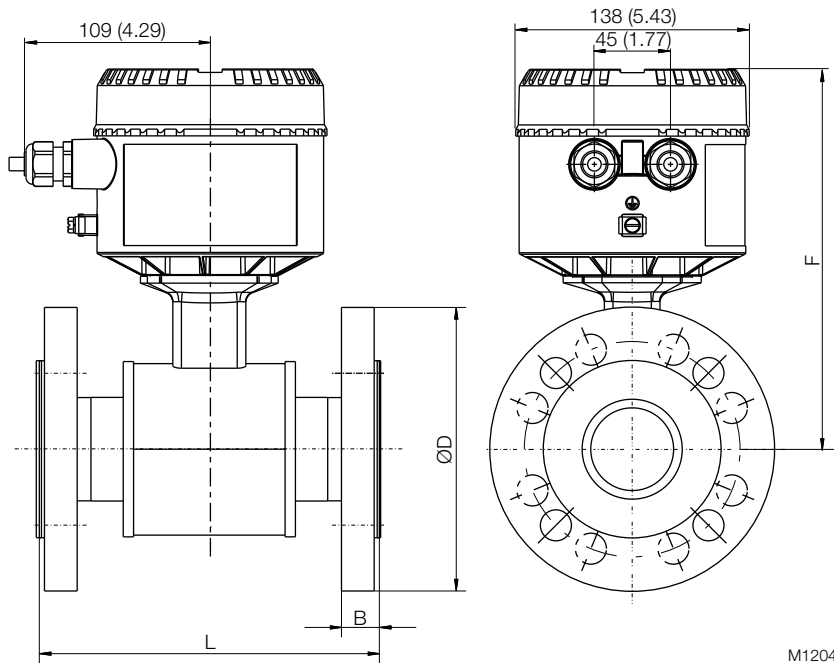

Fig. 19

Dimensions - Flange						Approx weight	
Nominal diameter	Process connection	D	B	L	F	Remote	Integral
DN 3 ... 10 ¹⁾ (1/8 ... 1/2" ²⁾)	EN 1092-1 PN 40	90 (3.54)	19 (0.75)	200 (7.84)	190 (7.56)	4.5 (9.92)	5 (11.02)
	ASME B16.5, CL 150	90 (3.54)	14.2 (0.56)				
	ASME B16.5, CL 300	95 (3.74)	17.3 (0.68)				
	JIS 10K	90 (3.54)	15 (0.59)				
DN 15 (1/2")	EN 1092-1 PN 40	95 (3.74)	19 (0.75)	200 (7.84)	190 (7.56)	7.5 (16.53)	8 (17.64)
	ASME B16.5, CL 150	90 (3.54)	14.2 (0.56)				
	ASME B16.5, CL 300	95 (3.74)	17.3 (0.68)				
	JIS 10K	95 (3.74)	15 (0.59)				
DN 20 (3/4")	EN 1092-1 PN 40	105 (4.13)	21 (0.83)	200 (7.84)	199 (7.83)	7.5 (16.53)	8 (17.64)
	ASME B16.5, CL 150	98.6 (3.88)	15.7 (0.62)				
	ASME B16.5, CL 300	117.3 (4.62)	18.7 (0.74)				
	JIS 10K	100 (3.94)	17 (0.67)				

Tolerance for L: +0 / -3 mm (+0 / -0.018 inch)

1) Connection flange DN 10.

2) Connection flange 1/2".

Dimensions - Flange						Approx weight	
Nominal diameter	Process connection	D	B	L	F	Remote	Integral
DN 25 (1")	EN 1092-1 PN 40	115 (4.53)	21 (0.83)	200 (7.84)	205 (8.07)	8.5 (17.74)	9 (19.84)
	ASME B16.5, CL 150	108 (4.25)	17.2 (0.68)				
	ASME B16.5, CL 300	124 (4.88)	20.5 (0.81)				
	JIS 10K	125 (4.92)	17 (0.67)				
DN 32 (1 1/4")	EN 1092-1 PN 40	140 (5.51)	21 (0.83)	200 (7.84)	210 (8.27)	10.5 (23.15)	11 (24.25)
	ASME B16.5, CL 150	117.3 (4.62)	18.7 (0.74)				
	ASME B16.5, CL 300	133.4 (5.25)	22.1 (0.87)				
	JIS 10K	135 (5.31)	19 (0.75)				
DN 40 (1 1/2")	EN 1092-1 PN 40	150 (5.91)	21 (0.83)	200 (7.84)	215 (8.46)	10.5 (23.15)	11 (24.25)
	ASME B16.5, CL 150	127 (5.00)	20.5 (0.81)				
	ASME B16.5, CL 300	155.4 (6.12)	23.6 (0.93)				
	JIS 10K	140 (5.51)	19 (0.75)				
DN 50 (2")	EN 1092-1 PN 40	165 (6.50)	23 (0.91)	200 (7.84)	225 (8.86)	10.5 (23.15)	11 (24.25)
	ASME B16.5, CL 150	152.4 (6.00)	22.1 (0.87)				
	ASME B16.5, CL 300	165.1 (6.50)	25.4 (1.00)				
	JIS 10K	155 (6.10)	19 (0.75)				
DN 65 (2 1/2")	EN 1092-1 PN 40	185 (7.28)	22 (0.87)	200 (7.84)	233 (9.17)	14.5 (31.97)	15 (33.07)
	EN 1092-1 PN 40	185 (7.28)	26 (1.02)				
	ASME B16.5, CL 150	177.8 (7.00)	25.4 (1.00)				
	ASME B16.5, CL 300	190.5 (7.50)	28.4 (1.12)				
	JIS 10K	175 (6.89)	21 (0.83)				
DN 80 (3")	EN 1092-1 PN 40	200 (7.87)	28 (1.10)	200 (7.84)	242 (9.53)	17.5 (38.58)	18 (39.68)
	ASME B16.5, CL 150	190.5 (7.50)	26.9 (1.06)				
	ASME B16.5, CL 300	209.6 (8.25)	31.4 (1.24)				
	JIS 10K	185 (7.28)	21 (0.83)				
DN 100 (4")	EN 1092-1 PN 40	220 (8.66)	24 (0.94)	200 (7.84)	256 (10.08)	20.5 (45.19)	21 (46.30)
	EN 1092-1 PN 40	235 (9.25)	28 (1.10)				
	ASME B16.5, CL 150	228.6 (9.00)	27.4 (1.08)				
	ASME B16.5, CL 300	254 (10.00)	35.8 (1.41)				
	JIS 10K	210 (8.27)	21 (0.83)				

Tolerance for L: +0 / -3 mm (+0 / -0.018 inch)

HygienicMaster FEH610 Electromagnetic flowmeter

Wafer type, DN 3 ... 40 (1/10 ... 1 1/2")

All specified dimensions and weights are in mm (inch) or kg (lb).

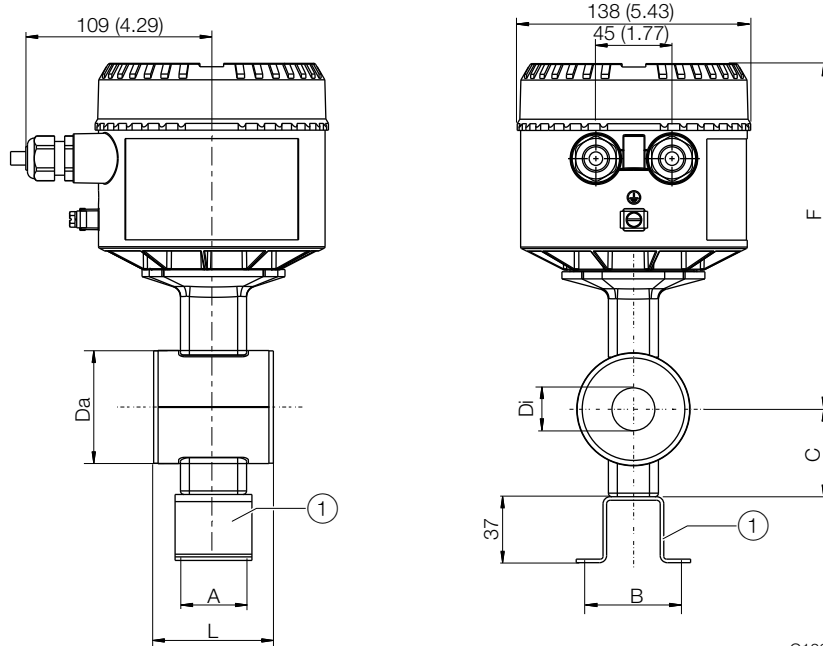

G12045

Fig. 20

① Bracket (optional), not available for 3A approval

Dimensions - Wafer type							Approx. weight	
Nominal diameter	Nominal pressure	Da	Di	C	F	L	Remote	Integral
DN 3 ... 8 (1/8" ... 5/16")	See chapter "Overview - Material load" on page 9	45 (1.77)	3 ... 8 (0.12 ... 0.31)	39 (1.54)	190 (7.48)	68 (2.68)	3 (6.61)	3.5 (7.72)
DN 10 (3/8")			10 (0.39)				3 (6.61)	3.5 (7.72)
DN 15 (1/2")			13 (0.51)				3 (6.61)	3.5 (7.72)
DN 20 (3/4")		54 (2.13)	18 (0.71)	44 (1.73)	199 (7.83)	78 (3.07)	3.5 (7.72)	4 (8.82)
DN 25 (1")		63.4 (2.50)	24 (0.94)	48 (1.89)	205 (8.07)	90 (3.54)	4 (8.82)	4.5 (9.92)
DN 32 (1 1/4")		73 (2.87)	30 (1.18)	53 (2.09)	210 (8.27)	98 (3.86)	4 (8.82)	4.5 (9.92)
DN 40 (1 1/2")		82 (3.23)	36 (1.42)	57 (2.24)	215 (8.46)	103 (4.06)	4.5 (9.92)	5 (11.02)

Installation hole spacing for angle bracket

Nominal diameter	A	B
DN 3 ... 20 (1/8" ... 3/4")	37 (1.46)	50 (1.97)
DN 25 ... 40 (1" ... 1 1/2")	42 (1.65)	70 (2.76)

Tolerance for L: +0 / -3 mm (+0 / -0.018 inch)

Wafer type, DN 50 ... 100 (2 ... 4")

All specified dimensions and weights are in mm (inch) or kg (lb).

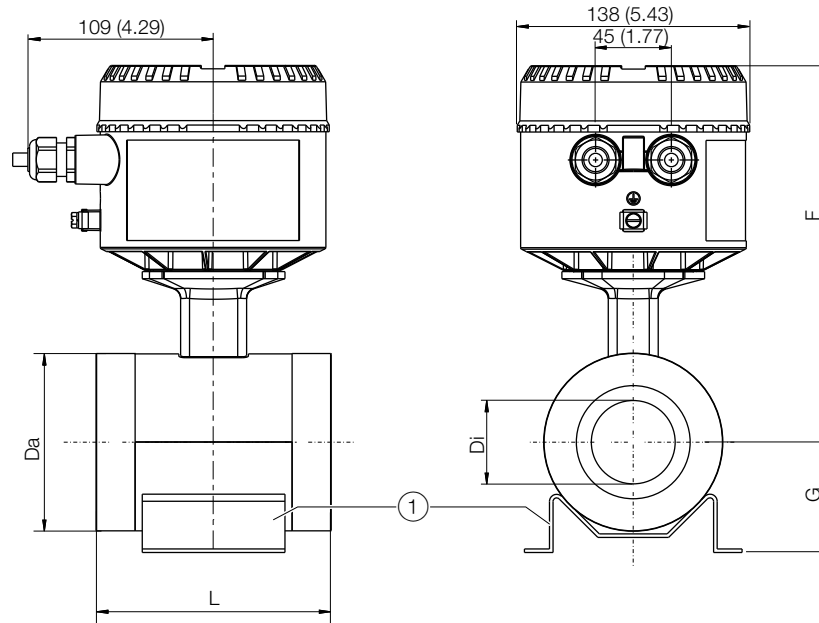

G12047

Fig. 21

① Bracket (optional), not available for 3A approval

Dimensions - Wafer type								Approx. weight	
Nominal diameter	Nominal pressure	Da	Di	F	G	L	L ¹⁾	Remote	Integral
DN 50 (2")	See chapter	99.6 (3.92)	47 (1.85)	225 (8.86)	62 (2.44)	117 (4.61)	117 (4.61)	5 (11.02)	5.5 (12.13)
DN 65 (2 1/2")	"Overview - Material load" on page 9	116 (4.57)	62 (2.44)	233 (9.17)	74 (2.91)	103 (4.06)	200 (7.87)	5.5 (12.13)	6 (13.23)
DN 80 (3")		133 (5.24)	74 (2.91)	242 (9.53)	86 (3.39)	103 (4.06)	200 (7.87)	6.5 (14.33)	7 (15.43)
DN 100 (4")		160.4 (6.31)	96 (3.78)	256 (10.08)	105 (4.13)	133 (5.24)	250 (9.84)	8.5 (18.74)	9 (19.84)

Tolerance for L: +0 / -3 mm (+0 / -0.018 inch)

1) New Lay Length.

HygienicMaster FEH610

Electromagnetic flowmeter

Variable process connections, DN 3 ... 40 (1/10 ... 1 1/2")

All specified dimensions and weights are in mm (inch) or kg (lb).

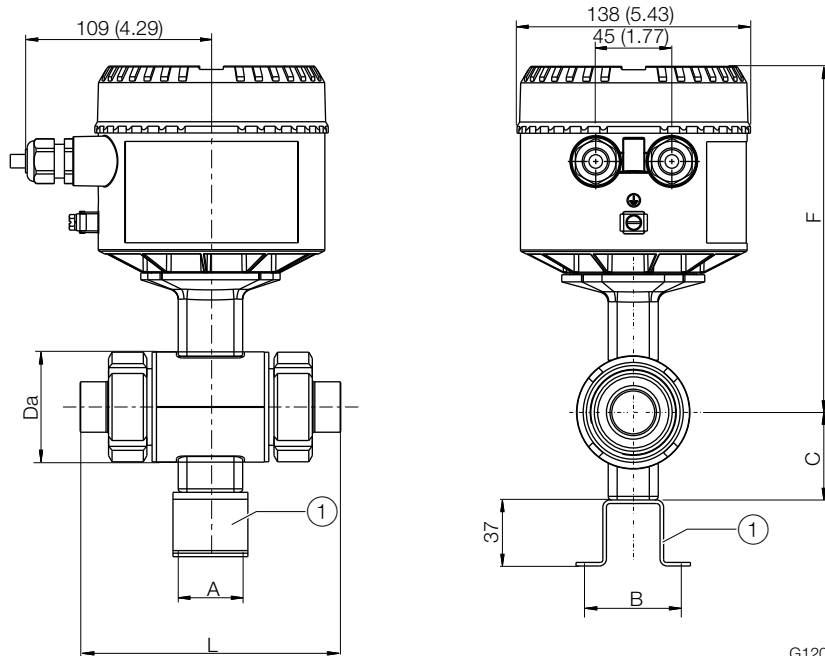

G12048

Fig. 22

① Bracket (optional), not available for 3A approval

Dimensions						Approx. weight ¹⁾	
Nominal diameter	Nominal pressure	Da	C	F	L	Remote	Integral
DN 3 ... 8 (1/8" ... 5/16")	See chapter "Overview - Material load" on page 9	45 (1.77)	39 (1.54)	190 (7.48)	Installation length including adapter for process connection see chapter "Adapter for variable process connections DN 3 ... 100 (1/8" ... 4")" on page 22.	2 (4.41)	2.5 (5.51)
DN 10 (3/8")		54 (2.13)	44 (1.73)	199 (7.83)			
DN 15 (1/2")		63.4 (2.50)	48 (1.89)	205 (8.07)			
DN 20 (3/4")		73 (2.87)	53 (2.09)	210 (8.27)			
DN 25 (1")		82 (3.23)	57 (2.24)	215 (8.46)			
DN 32 (1 1/4")							
DN 40 (1 1/2")							

Tolerance for L: +0 / -3 mm (+0 / -0.018 inch)

1) Plus process connection weight: See chapter "Adapter for variable process connections DN 3 ... 100 (1/8" ... 4")" on page 22

Installation hole spacing for angle bracket

Nominal diameter	A	B
DN 3 ... 20 (1/8" ... 3/4")	28 (1.1)	50 (1.97)
DN 25 ... 40 (1" ... 1 1/2")	46 (1.81)	70 (2.76)

Variable process connections, DN 50 ... 100 (2 ... 4")

All specified dimensions and weights are in mm (inch) or kg (lb).

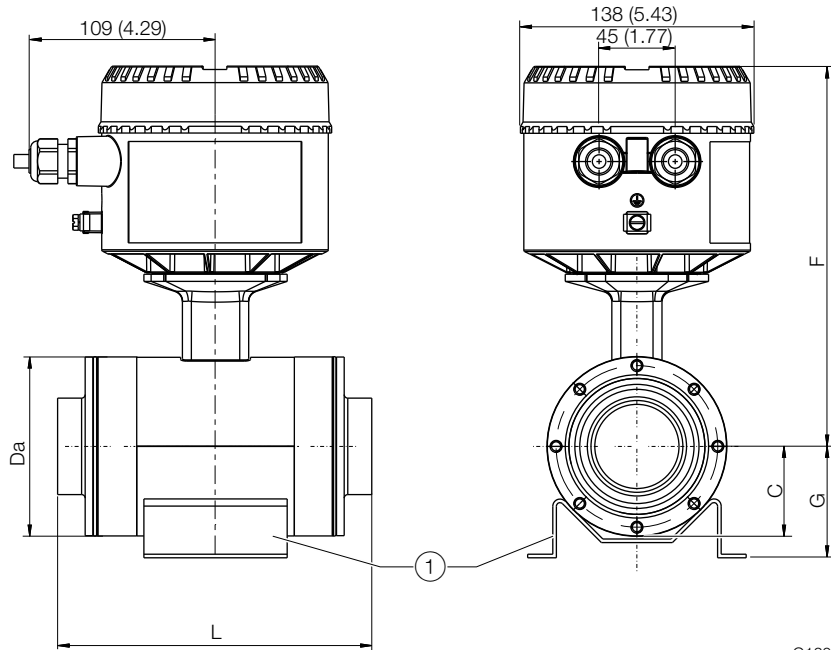

Fig. 23

① Bracket (optional), not available for 3A approval

Dimensions - Variable process connections							Approx. weight ¹⁾	
Nominal diameter	Nominal pressure	Da	F	C	G	L	Remote	Integral
DN 50 (2")	See chapter	99.6 (3.92)	225 (8.86)	50 (1.97)	62 (2.44)	Installation length including adapter for process connection see chapter "Adapter for variable process connections DN 3 ... 100 (1/8" ... 4")" on page 22.	5 (11.02)	5.5 (12.13)
DN 65 (2 1/2")	"Overview - Material load" on page 9	116 (4.57)	233 (9.17)	58 (2.28)	74 (2.91)		5.5 (12.13)	6 (13.23)
DN 80 (3")		133 (5.24)	242 (9.53)	66.5 (2.62)	86 (3.39)		7 (15.43)	7.5 (16.53)
DN 100 (4")		160.4 (6.31)	256 (10.08)	80.2 (3.16)	105 (4.13)		9.5 (20.94)	10 (22.05)

Tolerance for L: +0 / -3 mm (+0 / -0.018 inch)

1) Plus process connection weight: See chapter "Adapter for variable process connections DN 3 ... 100 (1/8" ... 4")" on page 22.

HygienicMaster FEH610

Electromagnetic flowmeter

Adapter for variable process connections DN 3 ... 100 (1/8" ... 4")

All specified dimensions and weights are in mm (inch) or kg (lb).

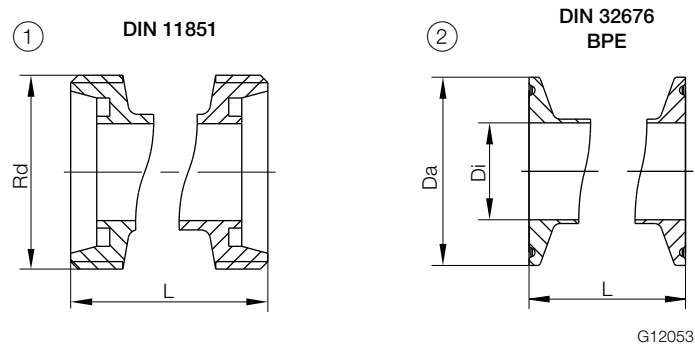

G12053

Fig. 24

① Food industry fitting ② Tri-Clamp

Food industry fitting acc. to DIN 11851

Nominal diameter	Nominal pressure	L (old ¹⁾)	L (new ²⁾)	Thread	∅ Di	Weight
DN 3 ... 10 (1/8 ... 3/8")	See chapter "Overview - Material load" on page 9	169 (6.65)	—	28 x 1/8"	10 (0.39)	0.5 (1.1)
DN 15 (1/2")				34 x 1/8"	16 (0.63)	
DN 20 (3/4")		180 (7.09)	—	44 x 1/6"	20 (0.79)	0.9 (2.0)
DN 25 (1")		207 (8.15)	—	52 x 1/6"	26 (1.02)	
DN 32 (1 1/4")		230 (9.06)	—	58 x 1/6"	32 (1.26)	1.4 (3.1)
DN 40 (1 1/2")		237 (9.33)	—	65 x 1/6"	38 (1.50)	
DN 50 (2")		243 (9.57)	—	78 x 1/6"	50 (1.97)	2.2 (4.9)
DN 65 (2 1/2")		245 (9.65)	330.5 (13.01)	96 x 1/6"	66 (2.60)	
DN 80 (3")		259 (10.20)	344.5 (13.56)	110 x 1/4"	81 (3.19)	3.2 (7.1)
DN 100 (4")		307 (12.09)	412.5 (16.24)	130 x 1/4"	100 (3.94)	4.4 (9.7)

1) Old Lay Length for replacement purposes only. Please refer to the model coding.

2) New Lay Length.

Tri-clamp coupling

Nominal diameter	Nominal pressure	Acc. to DIN 32676					Acc. to ASME BPE				
		L	Ø Da	Ø Di	Series	Weight	Process size	L	Ø Da	Ø Di	Weight
DN 3 ... 10 (1/8 ... 3/8")	See chapter "Overview - Material load" on page 9	163 (6.42)	34 (1.34)	10 (0.39)	3	0.5 (1.1)	1/2"	143 (5.63)	25 (0.98)	9.4 (0.37)	0.5 (1.1)
DN 15 (1/2")				16 (0.63)			3/4"			15.7 (0.62)	
DN 20 (3/4")		168 (6.61)	50.5 (1.99)	20 (0.79)	3	0.7 (1.5)	1"	277 (34.8)	50.4 (1.98)	22.1 (0.87)	0.7 (1.5)
DN 25 (1")		192 (7.56)		26 (1.02)	3	0.8 (1.8)	1 1/2"		22.1 (0.87)	1.2 (2.7)	
DN 32 (1 1/4")		209 (8.23)	50.5 (1.99)	32 (1.26)	3	1.5 (3.3)	—	—	—	—	—
DN 40 (1 1/2")		214 (8.43)		38 (1.50)	3	1.4 (3.1)	1 1/2"	277 (34.8)	50.4 (1.98)	34.8 (1.37)	1.8 (4.0)
DN 50 (2")		216 (8.50)	64 (2.52)	50 (1.97)	3	1.2 (2.7)	2"	277 (34.8)	63.9 (2.52)	47.5 (1.87)	
DN 65 (2 1/2")		221 (8.70) ¹⁾ 306.5 (12.07) ²⁾	91 (3.58)	66 (2.60)	1	1.6 (3.5)	2 1/2"		77.4 (3.05)	60.2 (2.37)	
DN 80 (3")		225 (8.86) ¹⁾ 310.5 (12.22) ²⁾	106 (4.17)	81 (3.19)	1	2.4 (5.3)	3"	337 (13.27)	90.9 (3.58)	72.9 (2.87)	3.6 (8.0)
DN 100 (4")		255 (8.86) ¹⁾ 360.5 (14.19) ²⁾	119 (4.69)	100 (3.94)	1	3.1 (6.8)	4"		118.8 (4.68)	97.4 (3.83)	

1) Old Lay Length for replacement purposes only. Please refer to the model coding.

2) New Lay Length.

HygienicMaster FEH610

Electromagnetic flowmeter

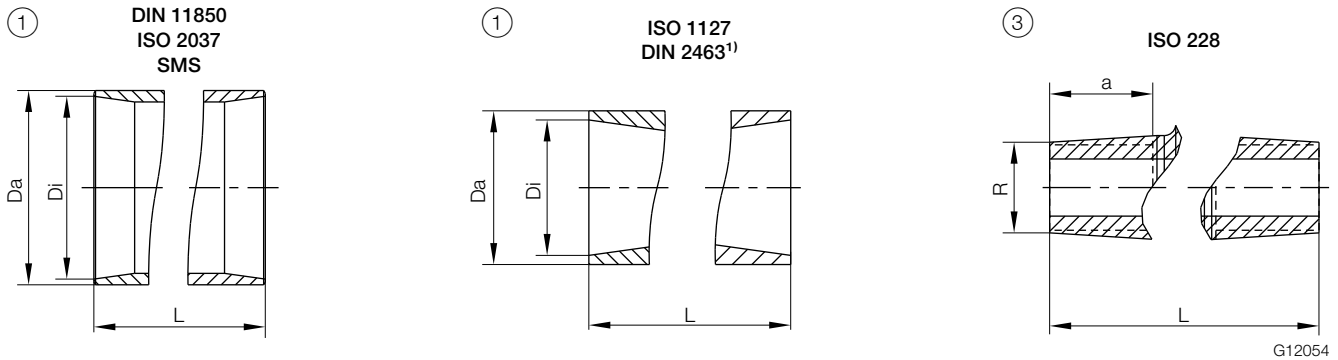

Fig. 25
 ① Welded spuds ② Male Thread

Welded spuds											
Nominal diameter	Nominal pressure	L	Acc. to DIN 11850			Acc. to ISO 1127			Acc. to SMS		Weight
			Ø Da	Ø Di	Series	Ø Da	Ø Di	Series	Ø Da	Ø Di	
DN 3 ... 10 (1/8 ... 3/8")	See chapter "Overview - Material load" on page 9	127 (5.0)	13 (0.51)	10 (0.39)	2	13.5 (0.53)	10.3 (0.41)	1	—	—	0.4 (0.9)
DN 15 (1/2")			19 (0.75)	16 (0.63)		21.3 (0.84)	18.1 (0.71)		—	—	0.4 (0.9)
DN 20 (3/4")		132 (5.2)	23 (0.91)	20 (0.79)	26.9 (1.06)	23.7 (0.93)	—	—	0.7 (1.5)		
DN 25 (1")		149 (5.87)	29 (1.14)	26 (1.02)	26.9 (1.06)	23.7 (0.93)	25 (0.98)	22.6 (0.89)	0.7 (1.5)		
DN 32 (1 1/4")		166 (6.54)	34 (1.34)	32 (1.26)	1	33.7 (1.33)	30.5 (1.20)	—	—	1.0 (2.2)	
DN 40 (1 1/2")		171 (6.73)	41 (1.61)	38 (1.50)	2	42.2 (1.66)	39 (1.54)	1	38 (1.50)	35.6 (1.40)	1.0 (2.2)
DN 50 (2")		173 (6.81)	54 (2.13)	50 (1.97)	3	51 (2.01)	47.8 (1.88)	2	51 (2.01)	48.6 (1.91)	1.0 (2.2)
DN 65 (2 1/2")		165 (6.50) ¹⁾	70 (2.76)	66 (2.60)	2	70 (2.76)	66 (2.60)	2	63.5 (2.50)	60.3 (2.37)	1.4 (3.1)
		250.5 (9.86) ²⁾									
DN 80 (3")		169 (6.65) ¹⁾	85 (3.35)	81 (3.19)	1	76.1 (3.00)	72.9 (2.87)	1	76.1 (3.00)	72.9 (2.87)	2.0 (4.4)
	254.5 (10.02) ²⁾										
DN 100 (4")	199 (7.83) ¹⁾	104 (4.09)	100 (3.94)	2	101.6 (4.00)	97.6 (3.84)	2	104 (4.09)	100 (3.94)	2.6 (5.7)	
	304.5 (11.99) ²⁾										

1) Old Lay Length for replacement purposes only. Please refer to the model coding.
 2) New Lay Length.

Welded spuds

Nominal diameter	Nominal pressure	L	Acc. to DIN EN ISO 2037		Acc. to DIN 2463		Weight
			Ø Da	Ø Di	Ø Da	Ø Di	
DN 3 ... 10 (1/8 ... 3/8")	See chapter "Overview - Material load" on page 9	127 (5.0)	12 (0.47)	10 (0.39)	13.5 (0.53)	10.3 (0.41)	0.4 (0.9)
DN 15 (1/2")			17.2 (0.68)	15.2 (0.60)	21.3 (0.84)	18.1 (0.71)	0.4 (0.9)
DN 20 (3/4")		132 (5.2)	21.3 (0.84)	19.3 (0.76)	26.9 (1.06)	23.7 (0.93)	0.7 (1.5)
DN 25 (1")		149 (5.87)	25 (0.98)	22.6 (0.89)	28 (1.10)	25 (0.98)	0.7 (1.5)
DN 32 (1 1/4")		166 (6.54)	33.7 (1.33)	31.3 (1.23)	35 (1.38)	32 (1.26)	1.0 (2.2)
DN 40 (1 1/2")		171 (6.73)	38 (1.5)	35.6 (1.40)	40 (1.57)	36.8 (1.45)	1.0 (2.2)
DN 50 (2")		173 (6.81)	51 (2.01)	48.6 (1.91)	52 (2.05)	49 (1.93)	1.0 (2.2)
DN 65 (2 1/2")		165 (6.50) ¹⁾ 250.5 (9.86) ²⁾	63.5 (2.50)	60.3 (2.37)	70 (2.76)	66 (2.60)	1.4 (3.1)
DN 80 (3")		169 (6.65) ¹⁾ 254.5 (10.02) ²⁾	76.1 (3.00)	72.9 (2.87)	85 (3.35)	81 (3.19)	2.0 (4.4)
DN 100 (4")		199 (7.83) ¹⁾ 304.5 (11.99) ²⁾	101.6 (4.00)	97.6 (3.84)	104 (4.09)	100 (3.94)	3.0 (6.6)

1) Old Lay Length. Please refer to the model coding to specify the lay length (old lay length / new lay length). Old Lay Length for replacement purposes only.

2) New Lay Length.

Male Thread ccc. to ISO 228 / DIN 2999

Nominal diameter	Nominal pressure	L	R	a	Weight
DN 3 ... 10 (1/8 ... 3/8")	See chapter "Overview - Material load" on page 9	139 (5.47)	3/8"	18 (0.71)	0.4 (0.9)
DN 15 (1/2")		139 (5.47)	1/2"	18 (0.71)	0.4 (0.9)
DN 20 (3/4")		164 (6.46)	3/4"	25 (0.98)	0.8 (1.8)
DN 25 (1")		179 (7.05)	1"	25 (0.98)	0.8 (1.8)

Welded spuds suitable for OD tubing

All specified dimensions and weights are in mm (inch) or kg (lb).

DN	Nominal pressure	Weld stub size	Di	Da	L	Weight
10 (3/8")	See chapter "Overview - Material load" on page 9	1/2"	9.40 (0.37)	12.70 (0.70)	127 (5.00)	0.4 (0.9)
15 (1/2")		3/4"	15.75 (0.62)	19.05 (0.75)	127 (5.00)	0.4 (0.9)
20 (1")		1"	22.10 (0.87)	25.40 (1.00)	132 (5.20)	0.7 (1.5)
25 (1")		1"	22.10 (0.87)	25.40 (1.00)	149 (5.87)	1.0 (2.2)
40 (1 1/2")		1 1/2"	34.80 (1.37)	38.10 (1.50)	171 (6.73)	
50 (2")		2"	47.50 (1.87)	50.80 (2.00)	173 (6.81)	

HygienicMaster FEH610

Electromagnetic flowmeter

Transmitter

Features

- 4 ... 20 mA current output.
- Current output in the event of an alarm can be configured to 21 ... 22.6 mA (NAMUR NE43).
- Measuring range: Can be configured between 0.02 ... $2 \times Q_{\max}$ DN.
- Operating mode for flow measurement can be configured.
- Programmable digital output. Can be configured as frequency output, pulse output or binary output.
- Damping: 0 ... 100 s configurable (1 τ).
- Low flow cut-off: 0 ... 20 % for current and pulse output.
- Empty pipe detection¹⁾.
- Simulation of current and binary output (manual process execution).

1) Requirements for Empty Pipe detector function:
The conductivity of the fluid must be $\geq 20 \mu\text{S/cm}$
Signal cable length must be $\leq 50 \text{ m}$ (164 ft)
Nominal diameter must be $\geq \text{DN } 10$

LCD indicator (option)

- High-contrast LCD indicator.
- Display of the current flow rate as well as the total flow rate.
- Application-specific visualizations which the user can select. Two operator pages can be configured to display multiple values in parallel.
- Plain text fault diagnostics
- Menu-guided parameterization with four buttons.
- "Easy Set-up" function for fast commissioning.
- Parameterization of the device through the front glass with the housing closed.

IP rating

- IP 65 / IP 67 in accordance with EN 60529

Vibration

In accordance with EN 60068-2

- Maximum deflection: 0.15 mm (0.006 inch) in the 10 ... 58 Hz range
- Maximum acceleration: 2 g¹⁾, in the 58 ... 150 Hz range

1) Peak load

Temperature Data

Ambient temperature range

-30 ... 60 °C (-22 ... 140 °F)

Storage temperature range

-30 ... 70 °C (-22 ... 158 °F)

NOTE

When operating below -20 °C (-4 °F), the LCD display can no longer be read and the electronics should be operated with as few vibrations as possible.

Full functionality is assured at temperatures above -20 °C (-4 °F).

Housing design

Integral mount design	
Housing	Plastic, RAL 9002 (light gray)
Cable gland	Polyamide

Remote mount design	
Housing	Cast aluminum, painted
Paint	Paint coat $\geq 80 \mu\text{m}$ thick, RAL 9002 (light gray)
Cable gland	Polyamide
Weight	1.8 kg (3.97 lb)

Dimensions

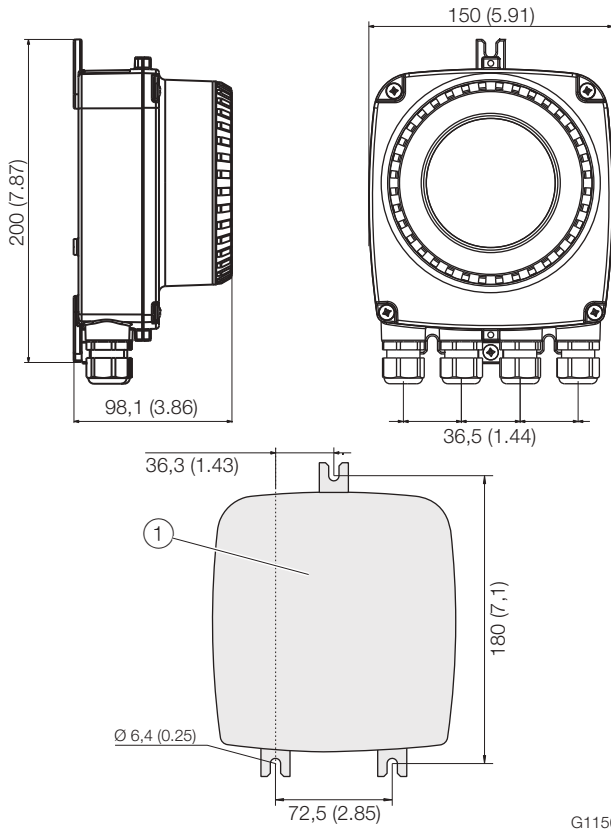

G11568

Fig. 26: Mounting dimensions (remote mount design)

① Hole pattern for mounting holes

HygienicMaster FEH610 Electromagnetic flowmeter

Electrical connections

Connection diagram

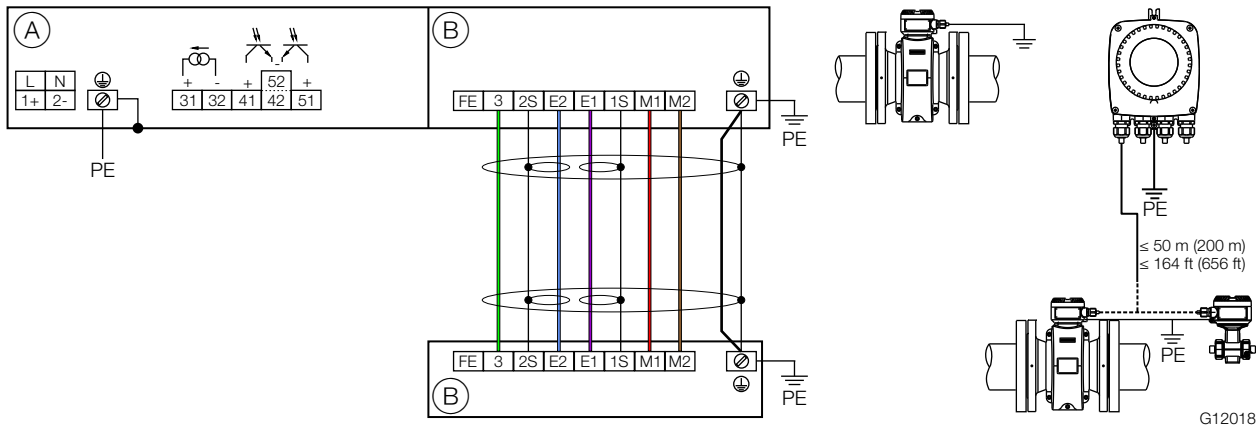

Fig. 27: Electrical connections

(A) Connections for power supply and outputs (B) Connections for signal cable (remote mount design only)

NOTE

For detailed information about grounding the transmitter and the flowmeter sensor, please refer to chapter "Grounding" in the Commissioning instruction or the operating instruction.

Connections for the power supply

AC power supply	
Terminal	Function / comments
L	Phase
N	Neutral conductor
PE / ⊕	Protective earth (PE)
DC voltage supply	
Terminal	Function / comments
1+	+
2-	-
PE / ⊕	Protective earth (PE)

Connections for outputs

Terminal	Function / comments
31 / 32	Active current output The current output is "active" mode. The source to drive the 20 mA loop is in-built in the transmitter.
41 / 42	Passive digital output DO1 The output can be configured as a pulse output, frequency output or switch output on site.
51 / 52	Passive digital output DO2 The output can be configured as a pulse output, frequency output or switch output on site.
⊕	Functional earth

Connections for the signal cable

Only for remote mount design.

Terminal	Function / comments	Color
FE	Not connected	—
3	Measurement potential	green
2S	Shield for E2	—
E2	Signal line	blue
E1	Signal line	violet
1S	Shield for E1	—
M1	Magnet coil	brown
M2	Magnet coil	red
⊕	Shield	—
—	Not connected	orange / yellow

Electrical data for inputs and outputs

Power supply L / N, 1+ / 2-

AC power supply	
Terminals	L / N
Operating voltage	100 ... 240 V AC (-15 % / +10 %), 47 ... 64 Hz
Power consumption	< 20 VA
Inrush current	8.8 A
DC voltage supply	
Terminals	1+ / 2-
Operating voltage	24 ... 48V DC (-10 % / +10 %)
Ripple	< 5 %
Power consumption	< 10 W
Inrush current	5.6 A

Current output 31 / 32

Can be configured for outputting mass flow, volume flow.

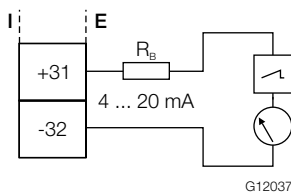

Fig. 28: Connection example active current output 31 / 32 (I = internal, E = external, R_B = load)

Current output	Active
Terminals	31 / 32
Output signal	4 ... 20 mA
Load R _B	0 Ω ≤ R _B ≤ 650 Ω

Digital output 41 / 42, 51 / 52

Can be configured as pulse, frequency or binary output.

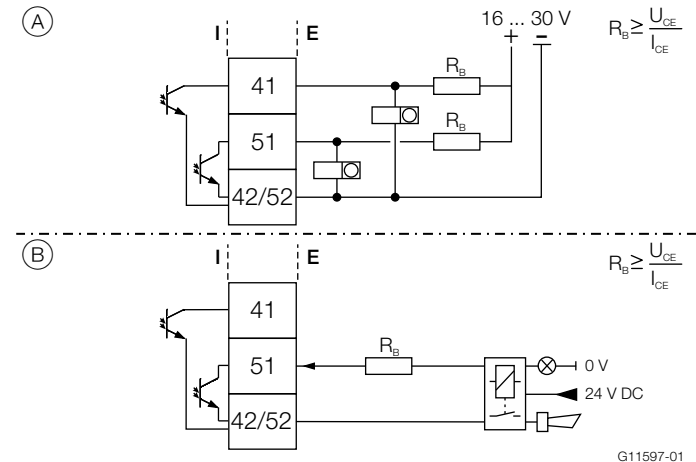

Fig. 29: Connection example (I = internal, E = external, R_B = load)

- (A) Passive digital output 41 / 42, 51 / 52 as pulse or frequency output
- (B) Passive digital output 51 / 52 as binary output

NOTE

- Terminals 42 / 52 have the same ground potential. Digital outputs 41 / 42 and 51 / 52 are not electrically isolated from each other.
- If you are using a mechanical counter, we recommend setting a pulse width of ≥ 30 ms and a maximum frequency of f_{max} ≤ 3 kHz.

Pulse / frequency output (passive)	
Terminals	41 / 42, 51 / 52
U _{max}	30 V DC
I _{max}	25 mA
f _{max}	10.5 kHz
Pulse width	0.1 ... 2000 ms

Binary output (passive)	
Terminals	41 / 42, 51 / 52
U _{max}	30 V DC
I _{max}	25 mA
Switching function	Can be configured using software as: System alarm, empty pipe alarm, max. / min. alarm, flow direction signaling, others

HygienicMaster FEH610

Electromagnetic flowmeter

Ordering Information

HygienicMaster FEH611

Electromagnetic Flowmeter system, integral mount, sensor housing stainless steel

	HygienicMaster FEH611	7,8	9,10	11	12,13,14,15	16,17	...	75,76
Explosion Protection Certification								
Without		Y0						
Housing Type / Housing Material / Cable Glands								
Single compartment / Plastic / M20 x 1.5			V1					
Single compartment / Plastic / NPT 1/2 in.			V2					
Sensor Style								
Standard Sensor Housing				F				
Meter size								
DN 3 (1/10 in.)					0003			
DN 4 (5/32 in.)					0004			
DN 6 (1/4 in.)					0006			
DN 8 (5/16 in.)					0008			
DN 10 (3/8 in.)					0010			
DN 15 (1/2 in.)					0015			
DN 20 (3/4 in.)					0020			
DN 25 (1 in.)					0025			
DN 32 (1-1/4 in.)					0032			
DN 40 (1-1/2 in.)					0040			
DN 50 (2 in.)					0050			
DN 65 (2-1/2 in.)					0065			
DN 80 (3 in.)					0080			
DN 100 (4 in.)					0100			
Process Connection Type								
Flanges DIN PN 16						1)	D2	
Flanges DIN PN 40						2)	D4	
Flanges ASME CL150 B16.5							A1	
Flanges ASME CL300 B16.5							A3	
Flanges JIS 10K							J1	
Male Thread acc. to ISO 228						4)	M1	
Food industry fittings acc. DIN 11851						3)	F1	
Weld stubs acc. ISO 2037						3)	R1	
Weld stubs acc. DIN 2463						3)	R2	
Weld stubs acc. DIN 11850						3)	R3	
Weld stubs acc. ISO 1127						3)	R4	
Weld stubs acc. OD tubing						5)	R5	
Weld stubs acc. SMS						6)	R6	
Tri-Clamp acc. DIN 32676						3)	T1	
Tri-Clamp acc. BPE						7)	T3	
Wafer						3)	W1	
Without adapter						8)	Y0	

Continued on next page

	HygienicMaster FEH611	7,8	...	18,19	20	21	22	23	24	25,26	27	...	75,76
Liner Material													
PFA					P1								
Others					Z9								
Process Connection Material													
Stainless steel					9) C								
316L (1.4404) stainless steel with EPDM gasket					E								
316L (1.4404) stainless steel with EPDM gasket + mounting bracket					10) F								
316L (1.4404) stainless steel with silicone gasket					G								
316L (1.4404) stainless steel with silicone gasket + mounting bracket					10) H								
Without process connection, without gasket, with mounting bracket					11) W								
Without process connection, without gasket, without mounting bracket					12) Y								
Others					Z								
Electrode Design													
Standard						1							
Pointed head						13) 5							
Others						9							
Measuring Electrodes Material													
Stainless steel 904 (1.4539)								A					
Hast. C-4 (2.4610)								D					
Titanium								F					
Tantalum								G					
Hast. B-3 (2.4600)								H					
Platinum-Iridium								J					
Stainless steel 316Ti (1.4571)								S					
Others								Z					
Grounding Electrode / Full Pipe Detection													
No grounding electrode / No full pipe detection									0				
Grounding electrode / No full pipe detection									2				
Others									9				
Grounding Accessories													
Without										A			
Protection Class Transmitter / Protection Class Sensor													
IP 67 / IP 67											70		
Power Supply													
100 ... 230 AC / 24 V DC, 50 Hz												F	
100 ... 230 AC / 24 V DC, 60 Hz												G	

Continued on next page

HygienicMaster FEH610

Electromagnetic flowmeter

	HygienicMaster FEH611	7,8	...	28	29,30	31	32,33	34,35,36	37,38,39	40,41,42	43,44	45,46	47,48	49,50,51	...	75,76
Display																
Without				0												
Display with Keypad				2												
Outputs																
1 Current output (active),																
2 Digital Outputs (passive)					A6											
Design Level																
(Specified by ABB)						A										
Usage Certifications																
Without							C0									
Inspection certificate 3.1 acc. EN 10204							C2									
Others							CZ									
Calibration Certifications																
ABB Standard								CMA								
3rd party witnessed calibration								CMW								
Other Usage Certifications																
Meter tube with PED certificate									CRP							
Potable Water and Food & Beverage Approvals																
3-A										CWG						
Without										CWY						
Sensor Length																
Old Lay length with DN 3 ... 100										14) J4						
New Lay length with DN 65, DN 80, DN 100										15) J5						
Other Options																
Without													K0			
Documentation Language																
German														M1		
English														M5		
Language package Western Europe / Scandinavia														MW		
Language package Eastern Europe														ME		
Pressure Bearing Parts Material Source																
Standard																MS0

Continued on next page

HygienicMaster FEH611		7,8	...	52,53,54	55,56,57	58,59,60	61,62,63	64,65,66	67,68	69,70,71	72,73,74	75,76
Tests and Reports												
Without				CR0								
Other				CRZ								
Configuration Type												
Parameters set to factory defaults				NC1								
Parameters set customer specific				NCC								
Transmitter Software Function Package												
Standard						NFS						
Calibration Type												
0,5% factory calibration						16) RCC						
Signal Cable												
Without								SC0				
Device Identification Plate												
Adhesive label										TC		
Others										TZ		
Temperature Range of Installation / Ambient Temperature												
Range												
Standard / -20 ... 60 °C (-4 ... 140 °F)										17) TK1		
Number of Testpoints												
2 Points												TV2
3 Points												TV3
5 Points												TV5
Verification Capability												
Disabled												V0

- 1) Available with DN 100 (4 in.) only
- 2) Available with DN 3 ... 80 (1/10 ... 3 in.)
- 3) For sizes and pressure rating available, refer to data sheet
- 4) Available for DN 3 ... 25 (1/10 ... 1 in.)
- 5) Available for DN 3 ... 50 (1/10 ... 2 in.)
- 6) Available for DN 25 (1 in.), DN 40 ... 100 (1 1/2 ... 4 in.)
- 7) Not available for DN 32 (1 1/4 in.)
- 8) For replacement purposes only
- 9) To be specified in case of process connection "flange"
- 10) No 3-A conformity
- 11) No 3-A conformity. To be specified in case of Process Connection "Wafer" or Process Connection "Without Adapter"
- 12) To be specified in case of Process Connection "Wafer" or Process Connection "Without Adapter"
- 13) Available from DN 10 (3/8 in.)
- 14) For replacement purposes
- 15) Not available for flange type sensors
- 16) 2 points calibration will be done. If more than 2 testpoints are required, please specify 3 or 5 points with option "Number of Testpoints"
- 17) Max. fluid temperature with standard sensor design: 130 °C (266 °F) with Liner Material PFA

HygienicMaster FEH610

Electromagnetic flowmeter

HygienicMaster FEH612

Electromagnetic Flowmeter system, remote mount, sensor housing stainless steel

	HygienicMaster FEH612	7,8	9,10	11	12,13,14,15	16,17	... 77,78
Explosion Protection Certification							
Without		Y0					
Housing Type / Housing Material / Cable Glands							
Remote / Plastic / M20 x 1.5			P1				
Remote / 'Plastic / NPT 1/2 in.			P2				
Sensor Style							
Standard Sensor Housing				F			
Meter size							
DN 3 (1/10 in.)						0003	
DN 4 (5/32 in.)						0004	
DN 6 (1/4 in.)						0006	
DN 8 (5/16 in.)						0008	
DN 10 (3/8 in.)						0010	
DN 15 (1/2 in.)						0015	
DN 20 (3/4 in.)						0020	
DN 25 (1 in.)						0025	
DN 32 (1-1/4 in.)						0032	
DN 40 (1-1/2 in.)						0040	
DN 50 (2 in.)						0050	
DN 65 (2-1/2 in.)						0065	
DN 80 (3 in.)						0080	
DN 100 (4 in.)						0100	
Process Connection Type							
Flanges DIN PN 16							1) D2
Flanges DIN PN 40							2) D4
Flanges ASME CL150 B16.5							A1
Flanges ASME CL300 B16.5							A3
Flanges JIS 10K							J1
Male Thread acc. to ISO 228							4) M1
Food industry fittings acc. DIN 11851							3) F1
Weld stubs acc. ISO 2037							3) R1
Weld stubs acc. DIN 2463							3) R2
Weld stubs acc. DIN 11850							3) R3
Weld stubs acc. ISO 1127							3) R4
Weld stubs acc. OD tubing							5) R5
Weld stubs acc. SMS							6) R6
Tri-Clamp acc. DIN 32676							3) T1
Tri-Clamp acc. BPE							7) T3
Wafer							3) W1
Without adapter							8) Y0

Continued on next page

		HygienicMaster FEH612	7,8	...	18,19	20	21	22	23	24	25,26	27	...	77,78
Liner Material														
PFA						P1								
Others						Z9								
Process Connection Material														
Stainless steel						9) C								
316L (1.4404) stainless steel with EPDM gasket						E								
316L (1.4404) stainless steel with EPDM gasket + mounting bracket						10) F								
316L (1.4404) stainless steel with silicone gasket						G								
316L (1.4404) stainless steel with silicone gasket + mounting bracket						10) H								
Without process connection, without gasket, with mounting bracket						11) W								
Without process connection, without gasket, without mounting bracket						12) Y								
Others						Z								
Electrode Design														
Standard								1						
Pointed head							13)	5						
Others								9						
Measuring Electrodes Material														
Stainless steel 904 (1.4539)									A					
Hast. C-4 (2.4610)									D					
Titanium									F					
Tantalum									G					
Hast. B-3 (2.4600)									H					
Platinum-Iridium									J					
Stainless steel 316Ti (1.4571)									S					
Others									Z					
Grounding Electrode / Full Pipe Detection														
No grounding electrode / No full pipe detection										0				
Grounding electrode / No full pipe detection										2				
Others										9				
Grounding Accessories														
Without											A			
Protection Class Transmitter / Protection Class Sensor														
IP 67 / IP 67												70		
IP 67 / IP 68											14)	76		
IP 67 / IP 68, signal cable fitted and potted											15)	77		
Power Supply														
Without													Y	

Continued on next page

HygienicMaster FEH610

Electromagnetic flowmeter

	HygienicMaster FEH612	7,8	...	28	29,30	31	32,33	34,35,36	37,38,39	40,41,42	43,44	45,46	47,48	49,50	51,52,53	... 77,78
Display																
Without				0												
Outputs																
Without				Y0												
Design Level																
(Specified by ABB)						A										
Usage Certifications																
Without							C0									
Inspection certificate 3.1 acc. EN 10204							C2									
Others							CZ									
Calibration Certifications																
ABB Standard								CMA								
3rd party witnessed calibration								CMW								
Other Usage Certifications																
Meter tube with PED certificate										CRP						
Potable Water and Food & Beverage																
Approvals																
3-A										CWG						
Without										CWY						
Power Supply Line Frequency																
50 HZ										16) F5						
60 Hz										17) F6						
Sensor Length																
Old Lay length with DN 3 ... 100													18) J4			
New Lay length with DN 65, DN 80, DN 100													19) J5			
Other Options																
Without															K0	
Documentation Language																
German																M1
English																M5
Language package Western Europe / Scandinavia																MW
Language package Eastern Europe																ME
Pressure Bearing Parts Material Source																
Standard																MS0

Continued on next page

HygienicMaster FEH612		7,8	...	54,55,56	57,58,59	60,61,62	63,64,65	66,67,68	69,70	71,72,73	74,75,76	77,78
Tests and Reports												
Without				CR0								
Other				CRZ								
Configuration Type												
Parameters set to factory defaults					NC1							
Parameters set customer specific					NCC							
Transmitter Software Function Package												
Standard						NFS						
Calibration Type												
0,5% factory calibration						20)		RCC				
Signal Cable												
Without								SC0				
5 m (approx. 15 ft)								SC1				
10 m (approx. 30 ft)								SC2				
15 m (approx. 49 ft)								SC3				
20 m (approx. 66 ft)								SC4				
25 m (approx. 82 ft)								SC5				
30 m (approx. 98 ft)								SC6				
35 m (approx. 115 ft)								SC7				
40 m (approx. 131 ft)								SC8				
50 m (approx. 164 ft)								SCA				
Device Identification Plate												
Adhesive label									TC			
Others									TZ			
Temperature Range of Installation / Ambient Temperature												
Range												
Standard / -20 ... 60 °C (-4 ... 140 °F)									21)			
Number of Testpoints												
2 Points										TV2		
3 Points										TV3		
5 Points										TV5		
Verification Capability												
disabled												

V0

- | | |
|--|---|
| <ul style="list-style-type: none"> 1) Available with DN 100 (4 in.) only 2) Available with DN 3 ... 80 (1/10 ... 3 in.) 3) For sizes and pressure rating available, refer to data sheet 4) Available for DN 3 ... 25 (1/10 ... 1 in.) 5) Available for DN 3 ... 50 (1/10 ... 2 in.) 6) Available for DN 25 (1 in.), DN 40 ... 100 (1 1/2 ... 4 in.) 7) Not available for DN 32 (1 1/4 in.) 8) For replacement purposes only 9) To be specified in case of process connection "flange" 10) No 3-A conformity 11) No 3-A conformity. To be specified in case of Process Connection "Wafer" or Process Connection "Without Adapter" 12) To be specified in case of Process Connection "Wafer" or Process Connection "Without Adapter" | <ul style="list-style-type: none"> 13) Available from DN 10 (3/8 in.) 14) Only available with remote transmitter, sealing compound (optional) D141B038U01 15) Only available with remote transmitter 16) 50 Hz (to be specified in case no transmitter is ordered) 17) 60 Hz (to be specified in case no transmitter is ordered) 18) For replacement purposes 19) Not available for flange type sensors 20) 2 points calibration will be done. If more than 2 testpoints are required, please specify 3 or 5 points with option "Number of Testpoints" 21) Max. fluid temperature with standard sensor design: 130 °C (266 °F) with Liner Material PFA |
|--|---|

HygienicMaster FEH610

Electromagnetic flowmeter

Remote transmitter FET612

FET612 Electromagnetic Flowmeter, remote transmitter for HygienicMaster FEH610.

	7,8	9,10	11,12	13	14	15,16	17,18,19	20,21	22,23	24,25	26,27,28
Remote transmitter FET612											
Explosion Protection Certification											
Without	Y0										
Housing Type / Housing Material / Cable Glands											
Field-mount / Single compartment / Aluminium / 4 x M20 x 1.5		F1									
Field-mount / Single compartment / Aluminium / 4 x NPT 1/2 in.		F2									
Protection Class Transmitter / Protection Class Sensor											
Standard / IP 67			70								
Power Supply											
100- 240 AC; 24 - 48 DC, 50 Hz					F						
100- 240 AC; 24 - 48 DC, 60 Hz					G						
Display											
Without					0						
Display with Keypad					2						
Outputs											
Current output (active), 2 Digital Outputs (passive)						A6					
Potable Water and Food & Beverage Approvals											
Without							CWY				
Other Options											
Without								K0			
Documentation Language											
German									M1		
English									M5		
Language package Western Europe / Scandinavia									MW		
Language package Eastern Europe									ME		
Device Identification Plate											
Adhesive label										TC	
Others										TZ	
Temperature Range of Installation / Ambient Temperature Range											
Standard / -20 ... 60 °C (-4 ... 140 °F)											TK1

Accessories

Wafer type accessories

Wafer type accessories is for mounting purposes and include Bolts, nuts, lockwashers.

Nominal size	Nominal pressure	Order code
DN 3 ... DN 10 (1/10 ... 3/8 in.)	PN 10 ... PN 40	D614L265U03
	ASME CL 150	D614L265U03
	ASME CL 300	D614L265U04
DN 15 (1/2 in.)	PN 10 ... PN 40	D614L265U03
	ASME CL 150	D614L266U05
	ASME CL 300	D614L266U06
DN 20 (3/4 in.)	PN 10 ... PN 40	D614L267U04
	ASME CL 150	D614L267U05
	ASME CL 300	D614L267U06
DN 25 (1 in.)	PN 10 ... PN 40	D614L268U04
	ASME CL 150	D614L268U05
	ASME CL 300	D614L268U06
DN 32 (1-1/4 in.)	PN 10 ... PN 40	D614L269U04
	ASME CL 150	D614L269U05
	ASME CL 300	D614L269U06
DN 40 (1-1/2 in.)	PN 10 ... PN 40	D614L270U04
	ASME CL 150	D614L270U05
	ASME CL 300	D614L270U06
DN 50 (2 in.)	PN 10 ... PN 40	D614L296U04
	ASME CL 150	D614L296U05
	ASME CL 300	D614L296U06
DN 65 (2-1/2 in.) Old lay length	PN 10 ... PN 16	D614L297U08
	PN 25 ... PN 40	D614L297U09
	ASME CL 150	D614L297U10
	ASME CL 300	D614L297U11
DN 65 (2-1/2 in.) New lay length	PN 10 ... PN 16	D614L297U15
	PN 25 ... PN 40	D614L297U16
	ASME CL 150	D614L297U17
	ASME CL 300	D614L297U18
DN 80 (3 in.) Old lay length	PN 10 ... PN 40	D614L298U08
	ASME CL 150	D614L298U09
	ASME CL 300	D614L298U10
DN 80 (3 in.) New lay length	PN 10 ... PN 40	D614L298U15
	ASME CL 150	D614L298U17
	ASME CL 300	D614L298U18
DN 100 (4 in.) Old lay length	PN 10 ... PN 16	D614L299U07
	PN 25 ... PN 40	D614L299U08
	ASME CL 150	D614L299U09
DN 100 (4 in.) New lay length	PN 10 ... PN 16	D614L299U15
	PN 25 ... PN 40	D614L299U16
	ASME CL 150	D614L299U17

HygienicMaster FEH610



Electromagnetic flowmeter

Welding adapter

The welding adapter is a tool for flowmeter sensors that feature weld stubs as the process connection type. It enables these weld stubs to be welded into the pipeline in a coplanar manner.

The welding adapter is made from stainless steel AISI 304 (1.4301)

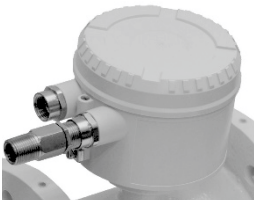
Nominal size	Order code
DN 3 ... DN 10 (1/10 ... 3/8 in.)	D413C470U01
DN 15 (1/2 in.)	D413C471U01
DN 20 (3/4 in.)	D413C472U01
DN 25 (1 in.)	D413C473U01
DN 32 (1-1/4 in.)	D413C474U01
DN 40 (1-1/2 in.)	D413C475U01
DN 50 (2 in.)	D413C488U03
DN 65 (2-1/2 in.), old lay length	D413C461U09
DN 65 (2-1/2 in.), new lay length	D413C461U11
DN 80 (3 in.), old lay length	D413C496U03
DN 80 (3 in.), new lay length	D413C496U05
DN 100 (4 in.), old lay length	D413C498U03
DN 100 (4 in.), new lay length	D413C498U05

Description	Order code
Infrared service port adapter FZA100  <p>G10788</p>	FZA100
Installation set for NPT 1/2" cable gland. For sealing the cable conduit during outdoor installation.  <p>G12058</p>	3KXF081300L0001
Adapter M20x1.5 to 1/2"NPT  <p>G12059</p>	D365B269U01
Signal cable	D173D031U01

Trademarks

™ Hastelloy C is a trademark of Haynes International

Notes

Notes

Contact us

ABB Limited

Measurement & Analytics

Howard Road, St. Neots
Cambridgeshire, PE19 8EU
UK

Tel: +44 (0)870 600 6122

Fax: +44 (0)1480 213 339

Mail: enquiries.mp.uk@gb.abb.com

ABB Inc.

Measurement & Analytics

125 E. County Line Road
Warminster, PA 18974
USA

Tel: +1 215 674 6000

Fax: +1 215 674 7183

ABB Automation Products GmbH

Measurement & Analytics

Dransfelder Str. 2
37079 Goettingen
Germany

Tel: +49 551 905-0

Fax: +49 551 905-777

Mail: [vertrieb.messtechnik-
produkte@de.abb.com](mailto:vertrieb.messtechnik-produkte@de.abb.com)

ABB Engineering (Shanghai) Ltd.

Measurement & Analytics

No. 4528, Kangxin Highway, Pudong
New District
Shanghai, 201319,
P.R. China

Tel: +86(0) 21 6105 6666

Fax: +86(0) 21 6105 6677

Mail: china.instrumentation@cn.abb.com

www.abb.com/flow

Note

We reserve the right to make technical changes or modify the contents of this document without prior notice.

With regard to purchase orders, the agreed particulars shall prevail. ABB does not accept any responsibility whatsoever for potential errors or possible lack of information in this document.

We reserve all rights in this document and in the subject matter and illustrations contained therein. Any reproduction, disclosure to third parties or utilization of its contents in whole or in parts – is forbidden without prior written consent of ABB.

Copyright© 2018 ABB

All rights reserved

3KXF232600R1001



Sales



Service