

ABB MEASUREMENT & ANALYTICS | DATA SHEET

## **PZT, PZF and non-configurable items**

Threaded, flanged and hygienic threaded adapters and accessories

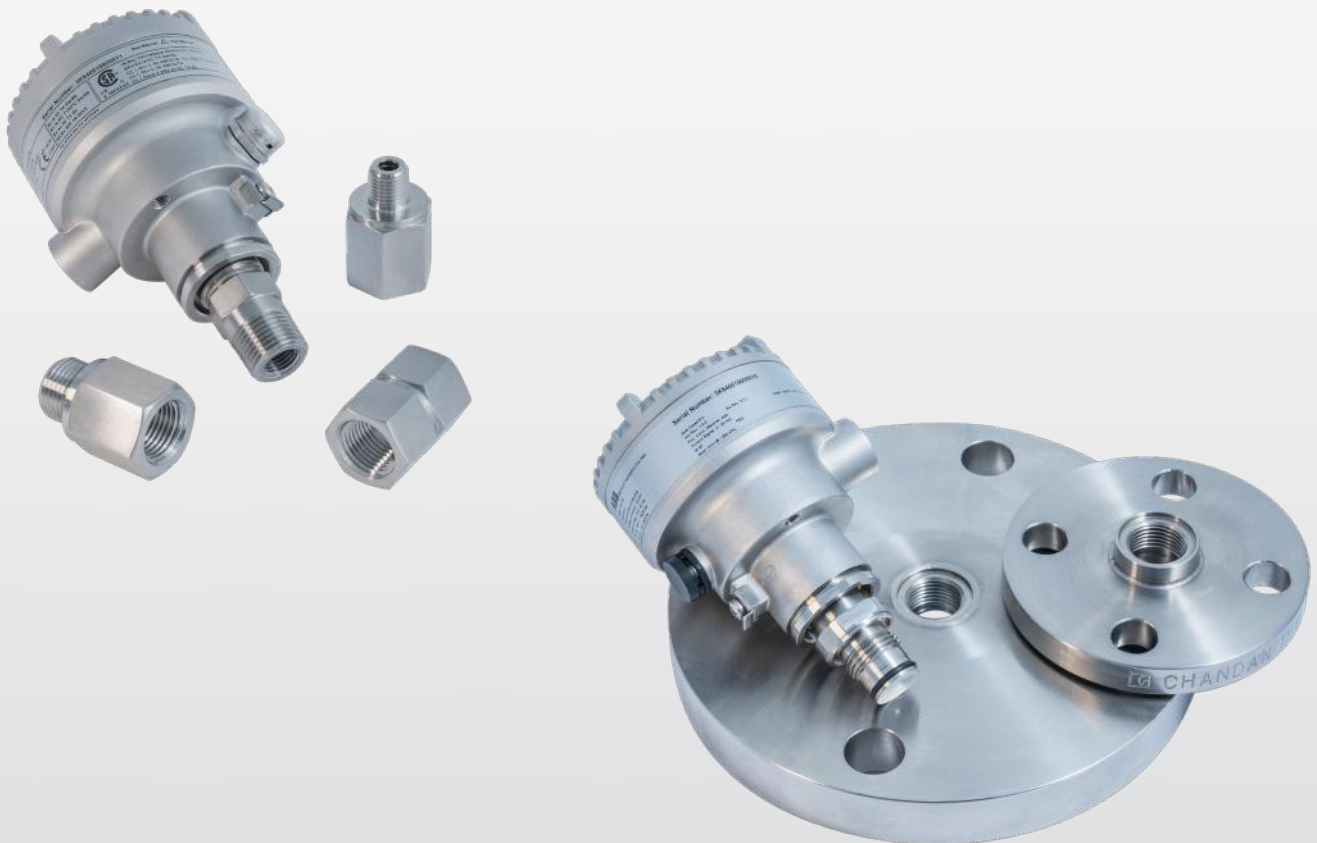

# Measurement made easy

Engineered solutions for all applications

## **Stainless steel construction**

- Optimized for use in harsh ambient conditions
- Extremely robust

## **Wide selection of versions**

- allows to meet application specific requirements

## Specifications

Please refer to the ordering information for variants availability

### Pressure limits

Flange to EN 1092-1	AISI 316 L ss flange @ 20 °C
PN 16	16 bar
PN 40	40 bar

Flange to ASME B16.5	AISI 316 L ss flange @ 100 °F (38 °C)
Class 150	275 psi
Class 300	720 psi

## Materials

### Adapters

AISI 316 ss / AISI 316 L ss (dual grade)

### Flanges

AISI 316 L ss

## Process connections

### Adapters

1/2 in - 14 NPT female, 1/2 in G male, 1 in G male,  
1 in - 11.5 NPT female, 1 in - 11.5 NPT male, M20 x 1.5 male

### Flanges

1 in, 2 in, 3 in to ASME; DN25, DN50, DN80 to EN 1092-1.

## Weight

- Adapters 100 to 900 g (0.22 to 2 lb) approx.
- Flanges 950 to 7000 g (2.1 to 15.6 lb) approx.

## Packaging

Cardboard box

**Mounting dimensions**  
**(not design data) - dimensions in mm (inch)**

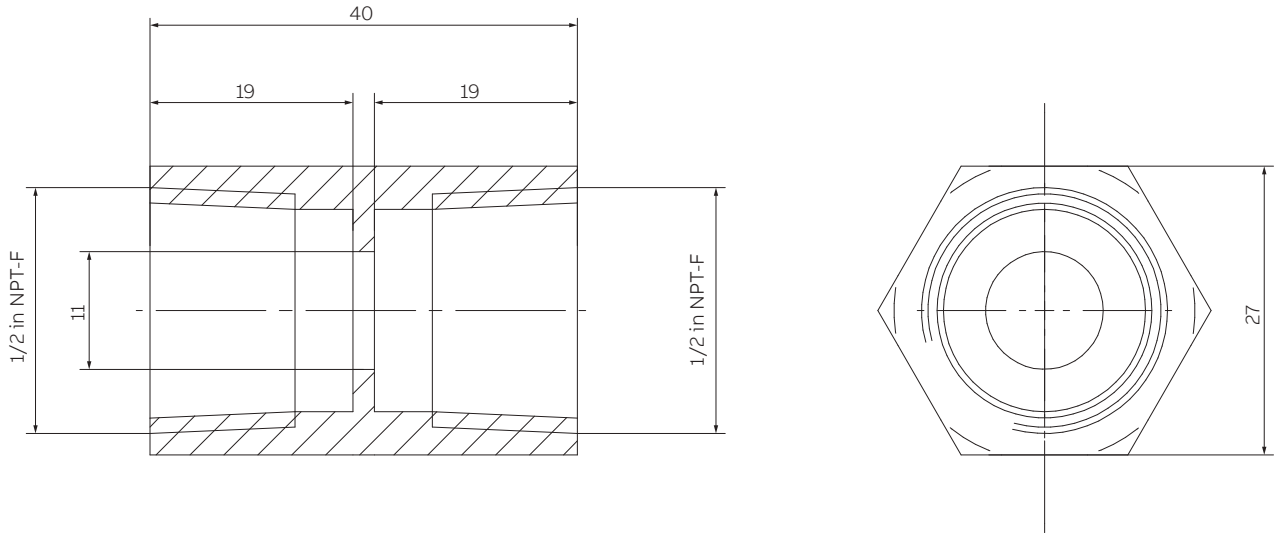

Figure 1 Straight adapter to 1/2 in NPT female process connection

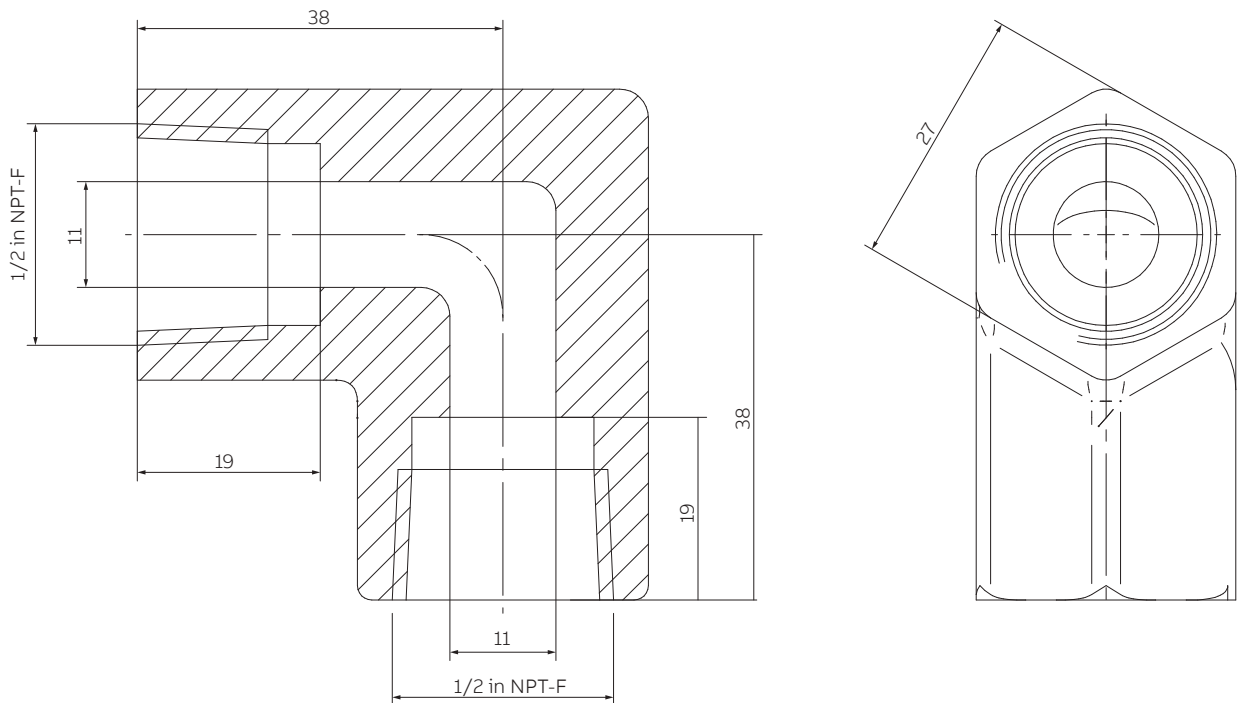

Figure 2 Angle adapter to 1/2 in NPT female process connection

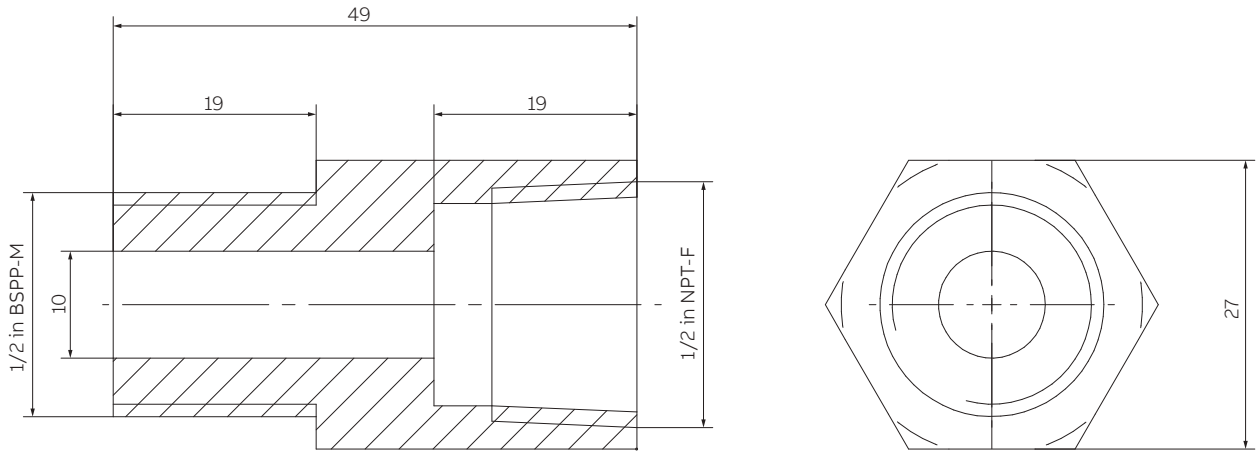

Figure 3 Straight adapter to 1/2 in G male process connection

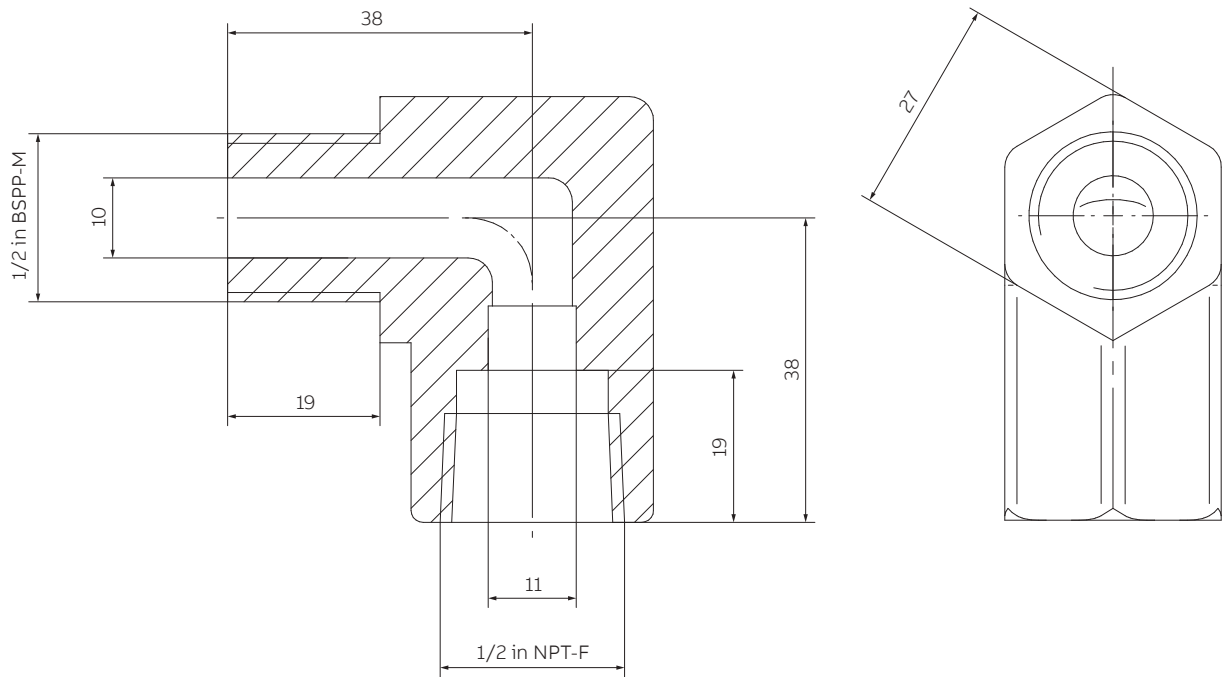

Figure 4 Angle adapter to 1/2 in G male process connection

### ...Mounting dimensions

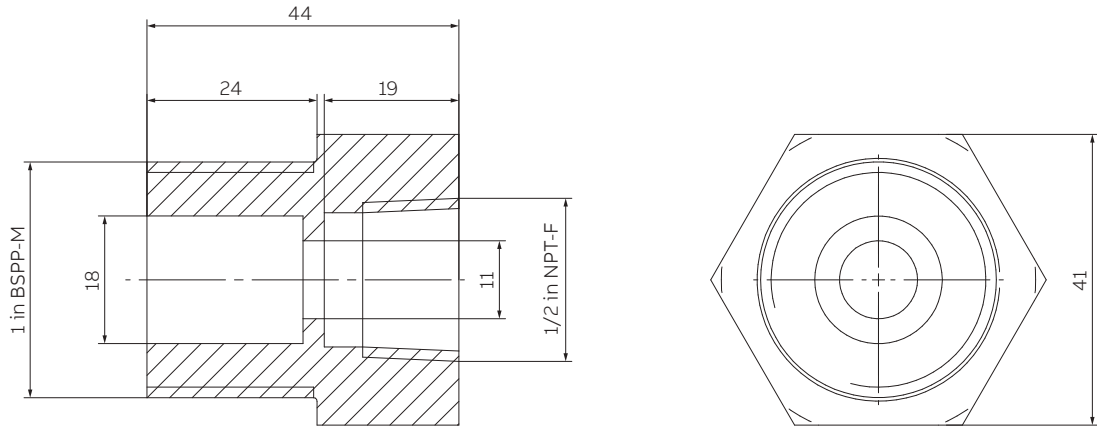

Figure 5 Straight adapter to 1 in G male process connection

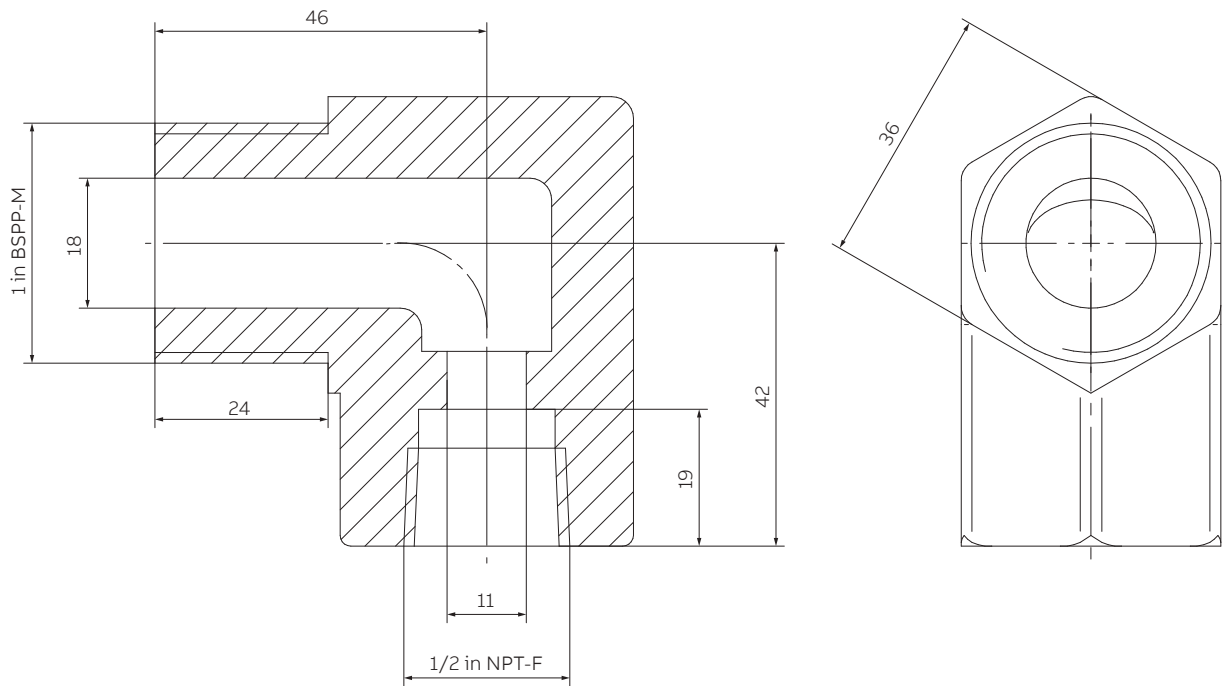

Figure 6 Angle adapter to 1 in G male process connection

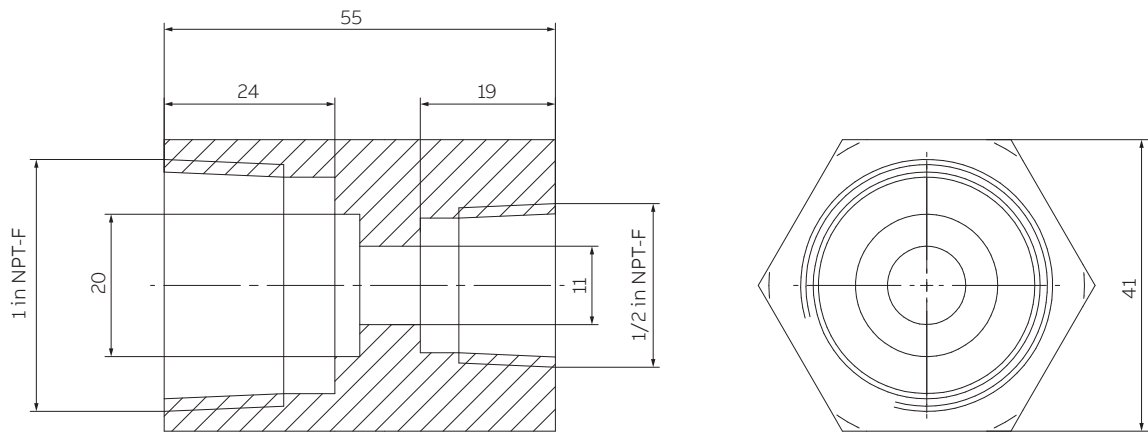

Figure 7

Figure 8 Straight adapter to 1 in NPT female process connection

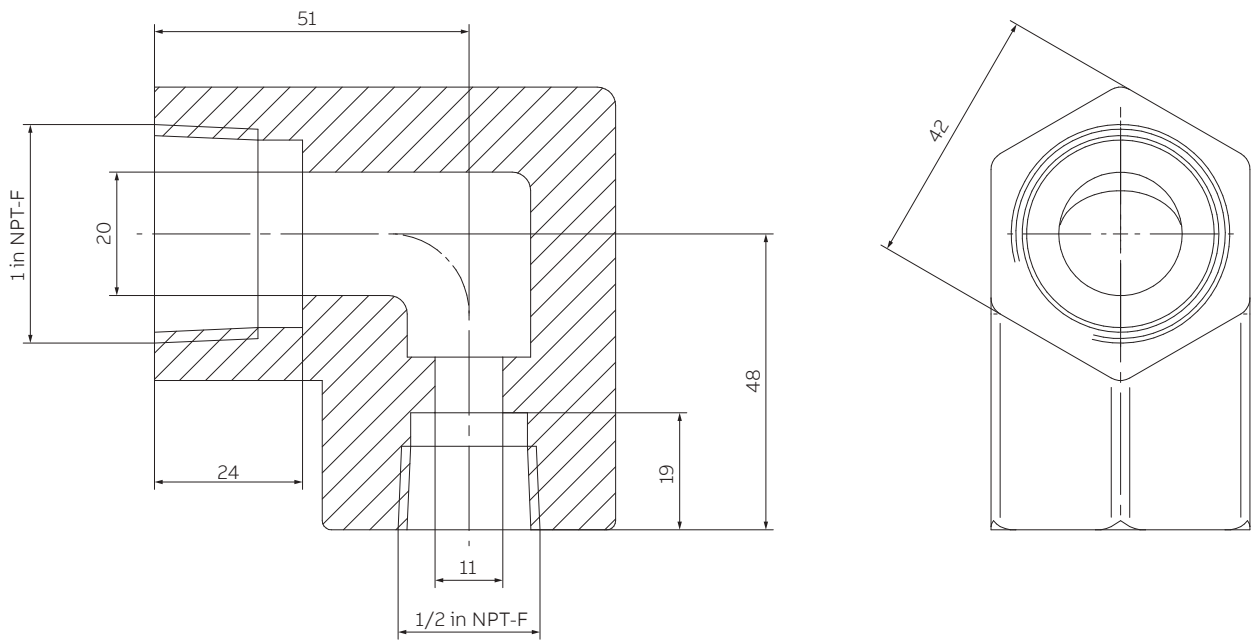

Figure 9 Angle adapter to 1 in NPT female process connection

### ...Mounting dimensions

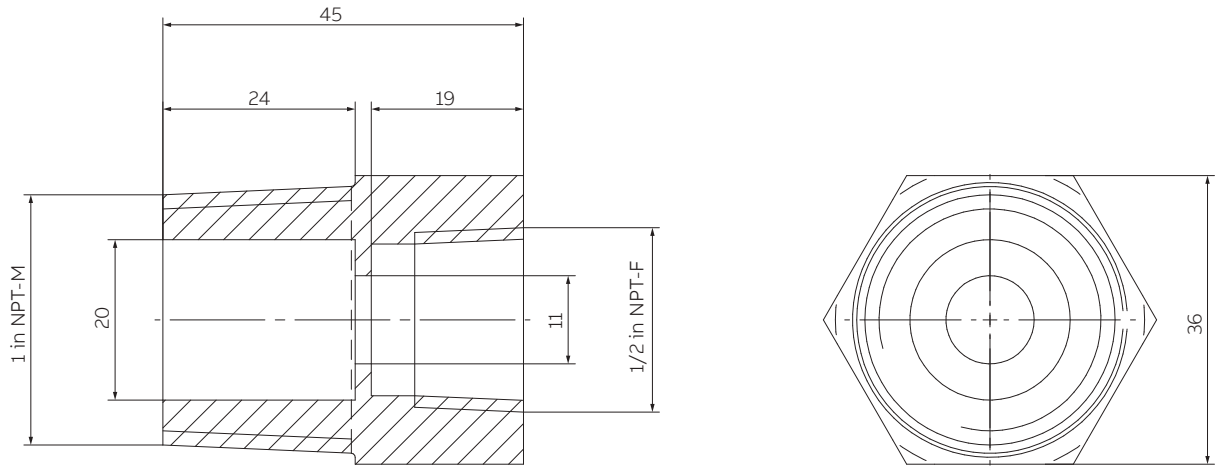

Figure 10 Straight adapter to 1 in NPT male process connection

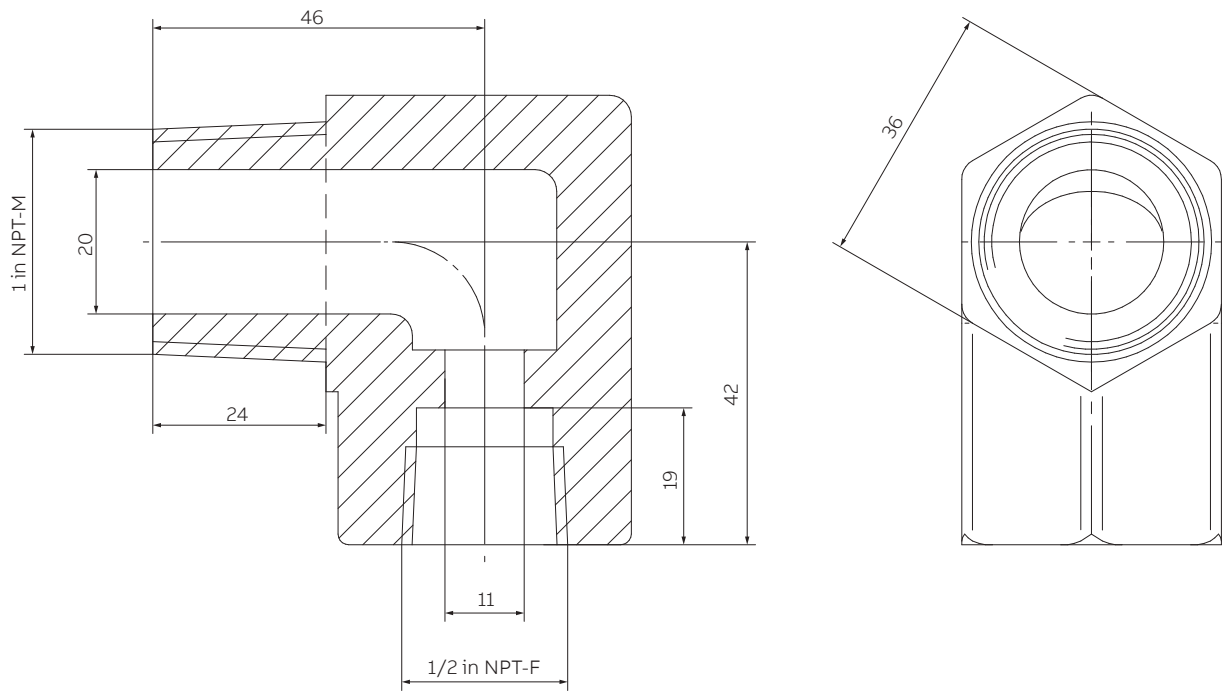

Figure 11 Angle adapter to 1 in NPT male process connection



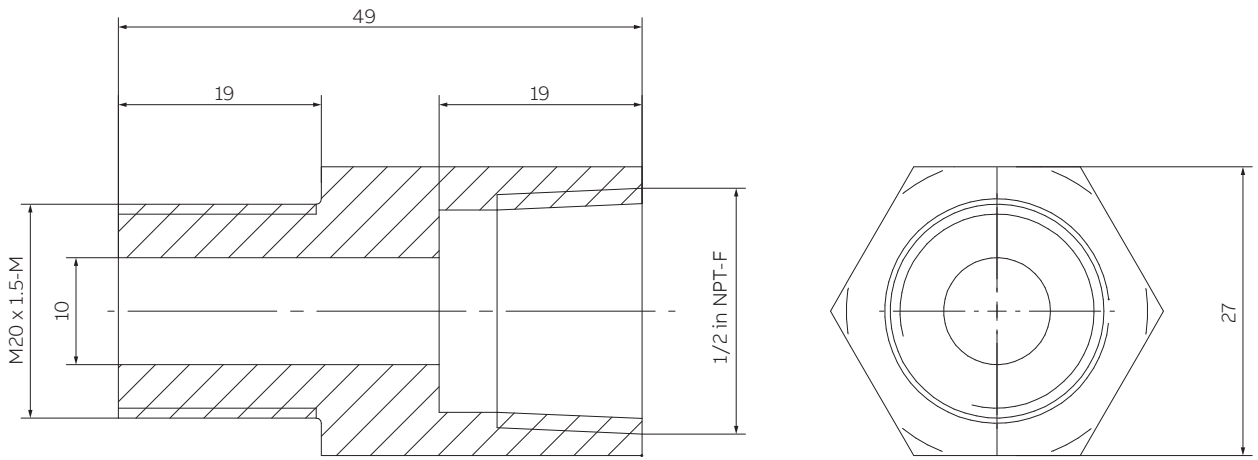

Figure 12 Straight adapter to M20 x 1.5 male process connection

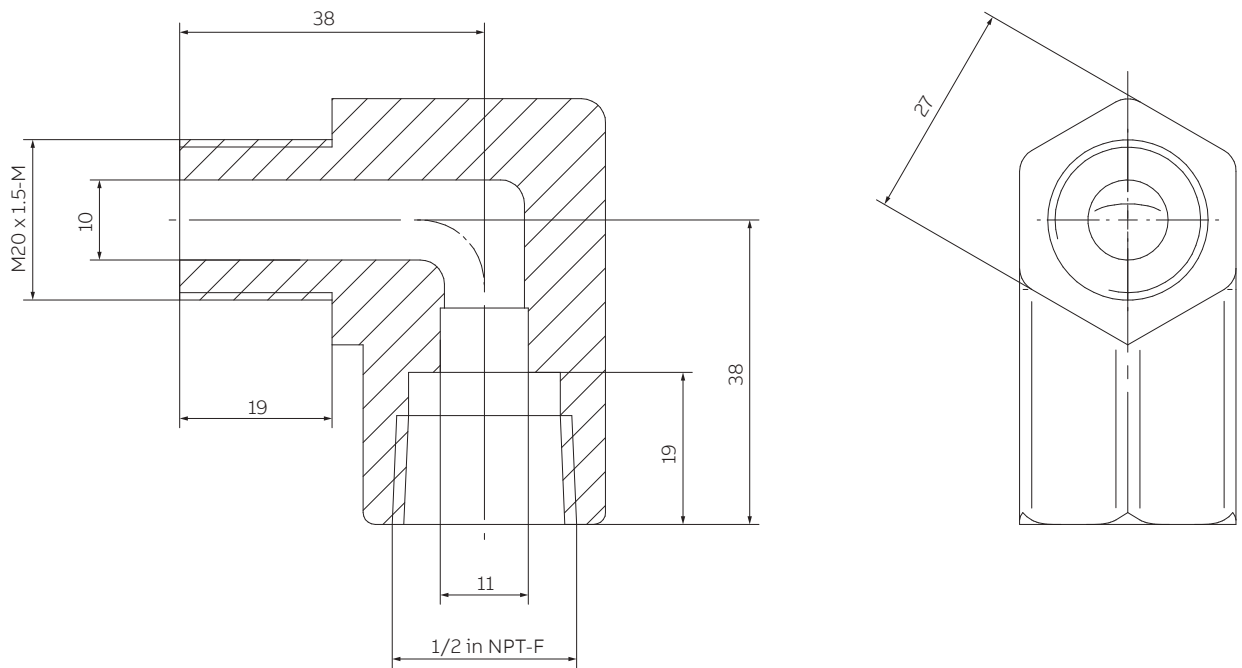
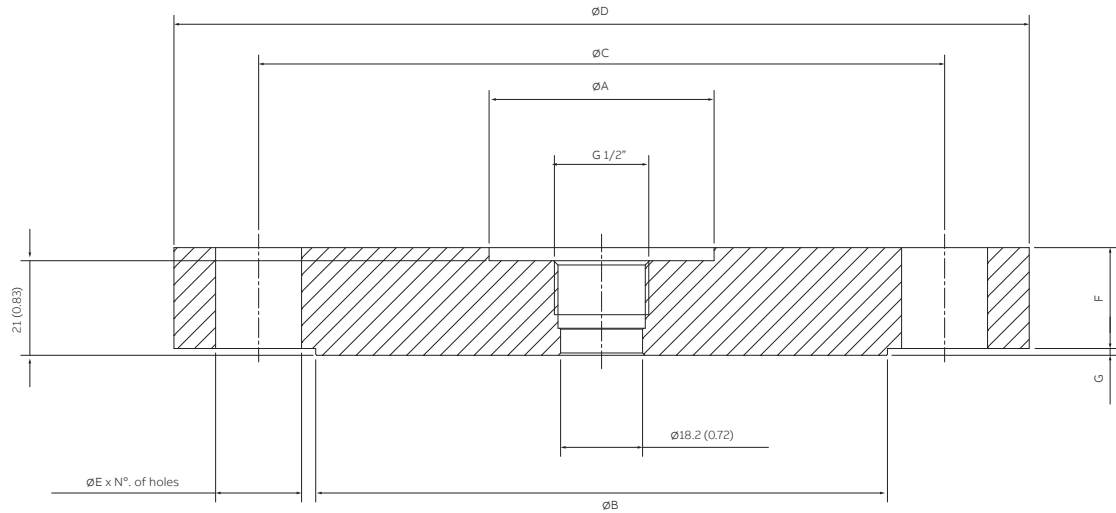

Figure 13 Angle adapter to M20 x 1.5 male process connection

## ...Mounting dimensions



Dimensions mm (inches) for ASME flange connection for PGS100/PAS100

Size/Rating	A (dia)	B (dia)	C (dia)	D (dia)	E (dia)	F	G	N° of holes
1 in ASME CL 150	50 (1.97)	50.8 (2)	79.2 (3.12)	108 (4.25)	15.9 (0.63)	12.7 (0.5)	1.5 (0.059)	4
1 in ASME CL 300	50 (1.97)	50.8 (2)	88.9 (3.5)	124 (4.88)	19.1 (0.75)	15.7 (0.62)	1.5 (0.059)	4
2 in ASME CL 150	50 (1.97)	91.9 (3.62)	120.6 (4.75)	152 (5.98)	19.1 (0.75)	17.5 (0.69)	1.5 (0.059)	4
2 in ASME CL 300	50 (1.97)	91.9 (3.62)	127 (5)	165 (6.5)	19.1 (0.75)	20.6 (0.81)	1.5 (0.059)	8
3 in ASME CL 150	50 (1.97)	127 (5)	152.4 (6)	190 (7.48)	19.1 (0.75)	22.4 (0.88)	1.5 (0.059)	4
3 in ASME CL 300	50 (1.97)	127 (5)	168.1 (6.62)	210 (8.27)	22.2 (0.87)	26.9 (1.06)	1.5 (0.059)	8

Figure 14 ASME flange connection for PGS100/PAS100

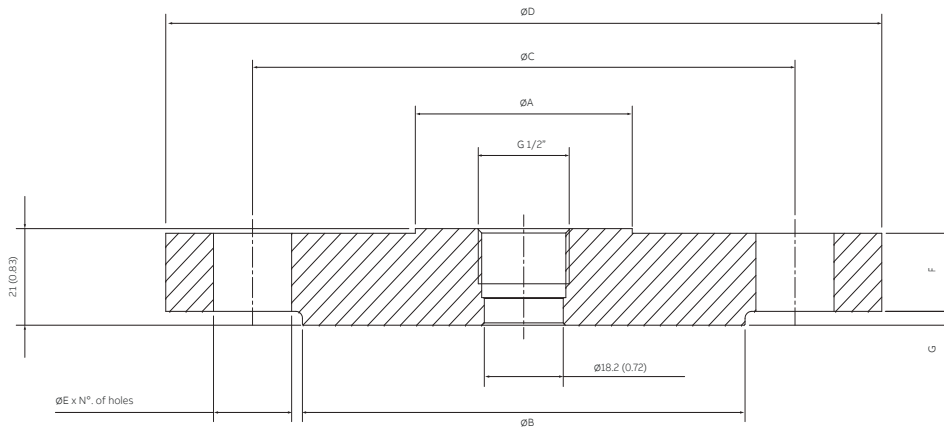

Dimensions mm (inches) for EN flange connection for PGS100/PAS100

Size/Rating	A (dia)	B (dia)	C (dia)	D (dia)	E (dia)	F	G	N° of holes
DN 25 EN 1092-1 PN 16	50 (1.97)	68 (2.68)	85 (3.35)	115 (4.53)	14 (0.55)	16 (0.63)	2 (0.078)	4
DN 25 EN 1092-1 PN 40	50 (1.97)	68 (2.68)	85 (3.35)	115 (4.53)	14 (0.55)	16 (0.63)	2 (0.078)	4
DN 50 EN 1092-1 PN 40	50 (1.97)	102 (4.02)	125 (4.92)	165 (6.50)	18 (0.71)	17 (0.67)	3 (0.118)	4
DN 80 EN 1092-1 PN 40	50 (1.97)	138 (5.43)	160 (6.30)	200 (7.87)	18 (0.71)	21 (0.83)	3 (0.118)	8

Figure 15 EN 1092-1 flange connection for PGS100/PAS100

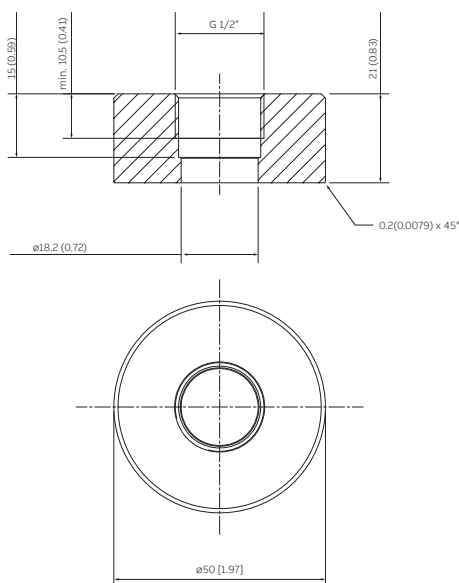

Figure 16 Welded socket (284903)

## Ordering Information

### Accessory ordering information for model PZT threaded adapters and PZF flanged adapters

Select one character or set of characters from each category and specify complete additional catalog number.

BASE MODEL - 1st to 3rd characters	PZT	X	X	X
<b>Screwed process connection adapter (suitable with process connection size code "B" at 13th character of PxS100)</b>				
<b>Connection thread to transmitter - 4th character</b>				
1/2 in-14 NPT female		2		
Front bonded G 1 in hygienic (adapter-compatible)		3		
Front bonded G 1/2 in		5		
<b>Process connection thread to process - 5th character</b>				
1/2 in - 14 NPT female			A	
1/2 in G male			B	
1 in G male			C	
1 in - 11.5 NPT female			D	
1 in - 11.5 NPT male			E	
M20 x 1.5 male			F	
1/4 in NPT male			G	
<b>Type of connection (orientation) - 6th character</b>				
Straight				S
90° angle				A

BASE MODEL - 1st to 3rd characters	PZF	X	XX	XX	XX
<b>Flanged process connection adapter (suitable with process connection size code "P" at 13th character of PxS100)</b>					
<b>Connection to transmitter - 4th character</b>					
Flanged to DP transmitter		F			
Screwed to front bonded connection		S			
<b>Flanged connection to process - 5th and 6th characters</b>					
ASME 1 in			A1		
ASME 2 in			A2		
ASME 3 in			A3		
EN DN25			D2		
EN DN50			D5		
EN DN80			D8		
<b>Flange rating - 7th character</b>					
ASME Class 150	(Note 1)			A	
ASME Class 300	(Note 1)			B	
EN PN16	(Note 2)			C	
EN PN40	(Note 2)			D	
<b>Flange form/seat finish - 8th character</b>					
Raised face (RF) serrated finish	(Note 1)				1
Form B1 to EN 1092-1	(Note 2)				2

Note 1: Not available with EN flanged connection code Dx

Note 2: Not available with ASME flanged connection code Ax

**Accessory ordering information for non-configurable items**

Select required item(s) according to application needs

Description	Part number
Adapter AISI 303 M16x1.5 / M20x1.5 K	284876
Adapter AISI 303 M16x1.5 / 1/2 NPT K	284877
M16 plastic cable gland	9287356
M16 nickel-plated brass Ex cable gland	9287600
Harting HAN 8D straight connector	3KXP002920U0100
M12 x 1 connector	3KXP002919U0100
Welding connection front bonded G 1/2" (diam. 50 mm)	284903
Welding connection for G 1" Hygienic (universal connection)	TBC
Welding connection front bonded G 1/2" (diam. 30 mm)	TBC

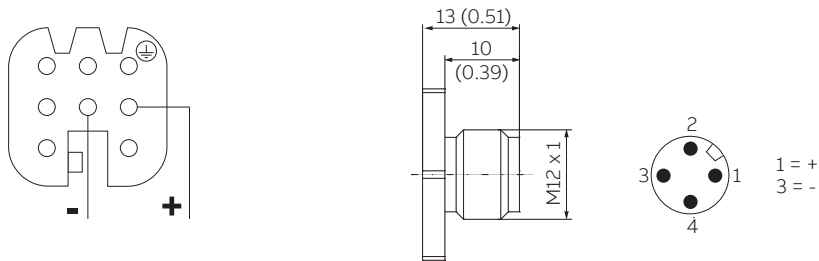

Figure 17 Pin layout of Harting HAN 8D (socket view) and M12 x 1 connector

---

## Notes



---

### **ABB Measurement & Analytics**

For your local ABB contact, visit:  
**[www.abb.com/contacts](http://www.abb.com/contacts)**

For more product information, visit:  
**[www.abb.com/measurement](http://www.abb.com/measurement)**

We reserve the right to make technical changes or modify the contents of this document without prior notice. With regard to purchase orders, the agreed particulars shall prevail. ABB does not accept any responsibility whatsoever for potential errors or possible lack of information in this document.

We reserve all rights in this document and in the subject matter and illustrations contained therein. Any reproduction, disclosure to third parties or utilization of its contents – in whole or in parts – is forbidden without prior written consent of ABB.