

Magnetic-inductive flow meter Wafer version Model FLC-1000EL

WIKA data sheet FL 20.02

Applications

- Water cycle
- Process applications

Special features

- Easy and time-saving installation
- Excellent price-performance ratio
- Electrodes from titanium, tantalum or platinum

Description

Magnetic-inductive flow meters are based on the Faraday principle, by which a conductor which traverses a magnetic field generates a potential oriented perpendicular to that field. The flow tube is enclosed by two flanges and also by two coils. The magnetic field which is generated by the electric current running through the coils induces a potential difference in the electrodes that is proportional to the flow being measured.

A WIKA signal converter, either attached directly to the instrument or separated from it (e.g. model FLC-608), generates the current to supply the magnetic coil, detects the potential difference between the electrodes, processes the signal to calculate the flow and manages communication with the external control systems.

The model FLC-1000EL has been developed for the accurate flow measurement of liquids and slurries that are difficult to quantify with other types of sensors.

The special wafer version enables easy installation between UNI 2223 flanges from PN 16 to PN 40 or between ANSI 150 and 300 flanges.

The measuring instrument has an excellent resistance to water, even with permanent immersion.



Model FLC-1000EL in separated version



Model FLC-1000EL with model FLC-608 signal converter in compact version

Specifications

Diameter and weight											
mm	25	40	50	65	80	100	125	150	200	250	300
in	1	1.5	2	2.5	3	4	5	6	8	10	12
Weight in kg ¹⁾	2.1	2.5	3.0	4.5	6.5	7.5	9.5	11.5	17	21	26

1) In separated version, without packaging

Specifications		
Compatible connecting flanges		
Per UNI 2223	PN 16 ... PN 40	
Per ANSI	<ul style="list-style-type: none"> ■ 150 ■ 300 	
Maximum pressure		
Diameter > DN 200	16 bar	
Diameter ≤ DN 150	40 bar	
Materials		
Sensor housing	Carbon steel, painted with acrylic	
Flow tube	Stainless steel AISI 304	
Electrodes	<ul style="list-style-type: none"> ■ Hastelloy C[®] ■ Titanium ■ Tantalum ■ Platinum 	
Flow tube lining ¹⁾	<ul style="list-style-type: none"> ■ PTFE (for pipe diameters DN 25 ... DN 100), on request also for DN > 100 ■ Hard rubber (ebonite) (for diameter ≥ DN 100 and for applications in the food industry) 	
Flow tube lining and medium temperature ²⁾	Flow tube lining	Medium temperature ³⁾
	PTFE	-40 ... +130 °C [-40 ... +266 °F] (-40 ... +180 °C [-40 ... +356 °F] on request)
	Hard rubber (ebonite)	-40 °C ... +80 °C [-40 ... +176 °F]
Painting of sensor housing and flange	Acrylic paint (painting for class C4 environments on request)	
Available flange standards	EN 1092-1, ANSI 150, ANSI 300, ANSI 600, ANSI 900, DIN 2501, BS 4504, AS 2129 (table D - E - F), AS 4087, ISO 7005-1, KS 10K	
Ingress protection per EN 60529	IP68 (continuous immersion to 1.5 m)	
Compatible signal converters	<ul style="list-style-type: none"> ■ Model FLC-608A/B/R/P/I ■ Model FLC-406 	
Electrical connection	Cable gland M20 x 1.5, terminal block and sealing resin	

1) Approvals for use in drinking water applications: WRAS, FDA, DPR 777/82 and DM 174.

2) The maximum permissible temperature of the process liquid is limited by the lining material.

3) Compact version T_{max}: 80 °C [176 °F]

Calibration and maximum measuring deviation

The sensors of the model FLC-1000EL belong to reference group B1 (per ISO 11631). Each sensor is wet-calibrated on a hydraulic test bench which is fitted with a reference weighting system and is SIT certified. The measuring deviation of the calibration is 0.2 % ±2 mm/s. The repeatability is 0.1 %.

Integration of the flow meter

The model FLC-1000EL sensors can be combined with all WIKA signal converters. In the separated version, the sensor is connected with the signal converter via a cable, whose length depends on the electric conductivity of the liquid. The maximum length of the cable is 100 m (30 m in combination with battery-operated electronics).

For pipe diameters \geq DN 40 [1.5"] a grounding electrode and an empty-pipe electrode (empty-pipe alarm) are supplied to detect partially filled flow tubes.

Dimensions in mm

Model FLC-1000EL in separated version

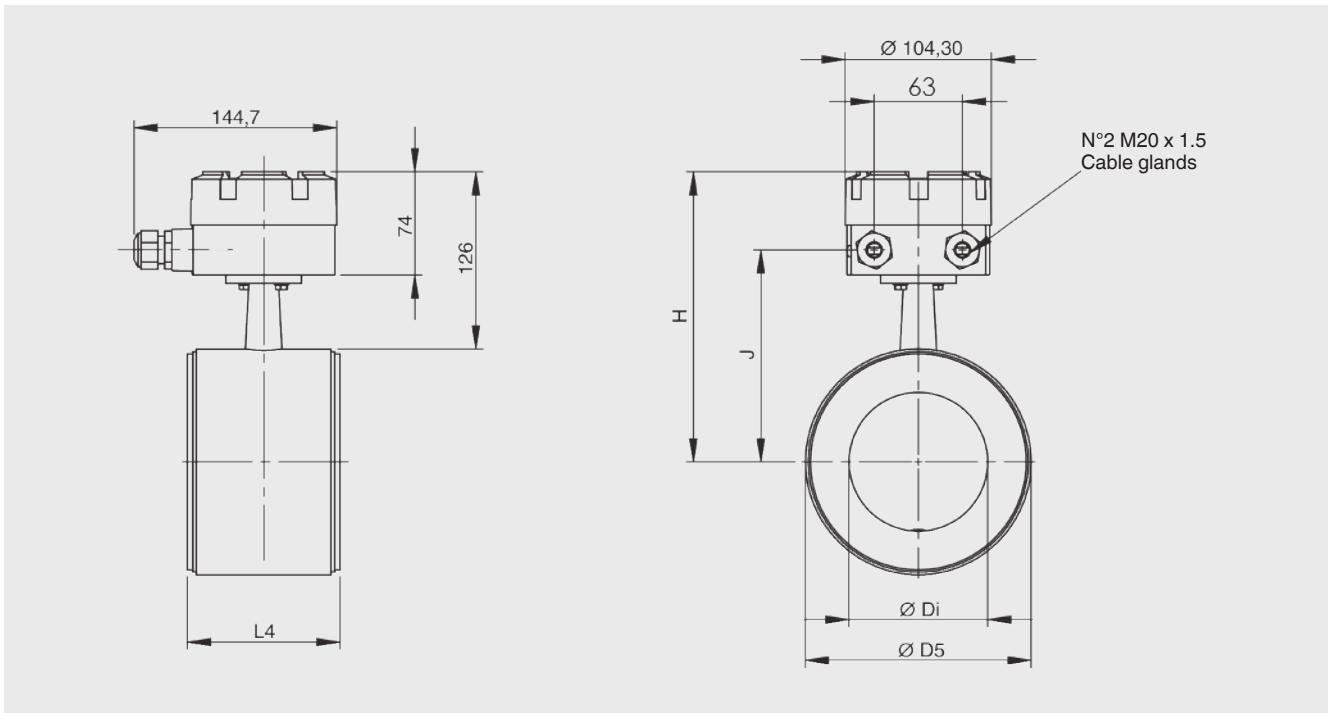

DN	L4	Tue	D5	H	J
25	86	24	74	163	108
32	87	32	83	168	112
40	87	35	88	170	115
50	87	47	102	177	122
65	96	63	114	183	128
80	90	75	127	190	134
100	109	99	161	207	151
125	110	124	186	219	164
150	130	152	216	234	179
200	169	201	267	260	204
250	169	255	319	286	230
300	195	308	371	312	256

Model FLC-1000EL in combination with model FLC-608A/B/R - compact version

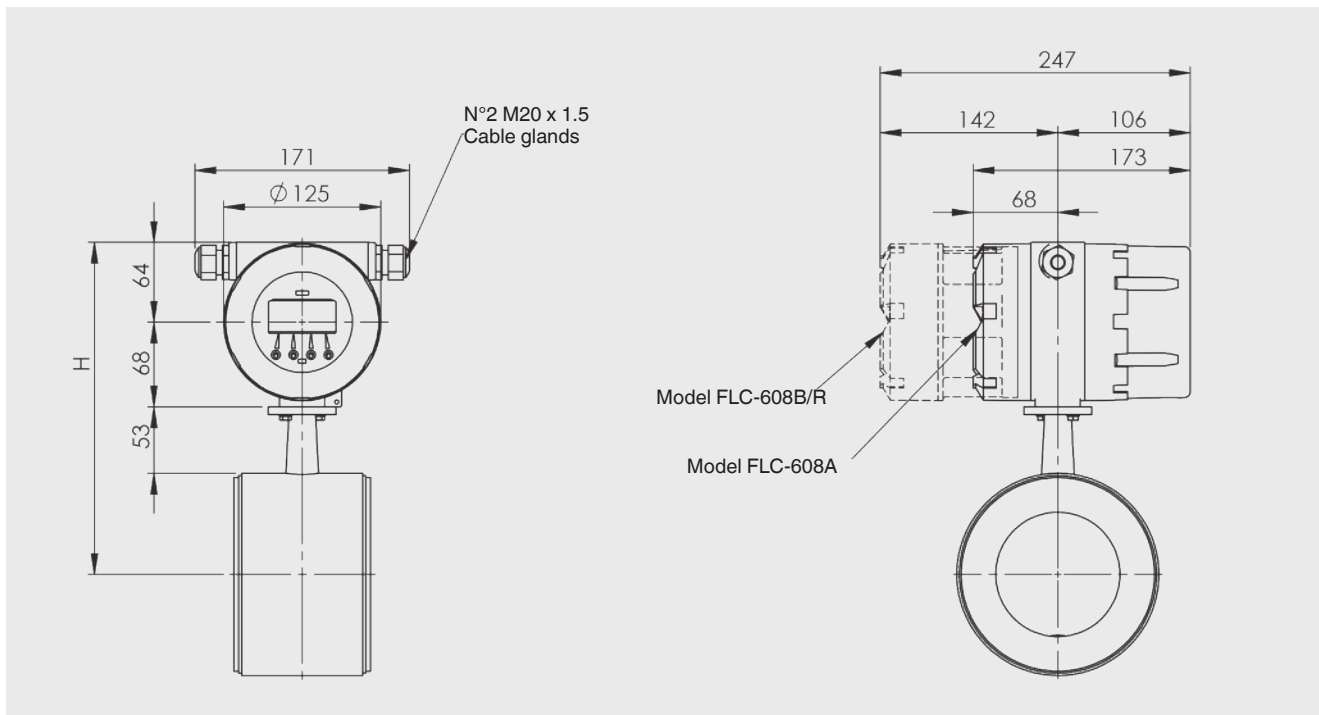

DN	H
25	222
32	227
40	229
50	236
65	242
80	249
100	266
125	278
150	293
200	319
250	345
300	371

Separated version: Model FLC-1000EL in combination with signal converter, model FLC-406, back mount

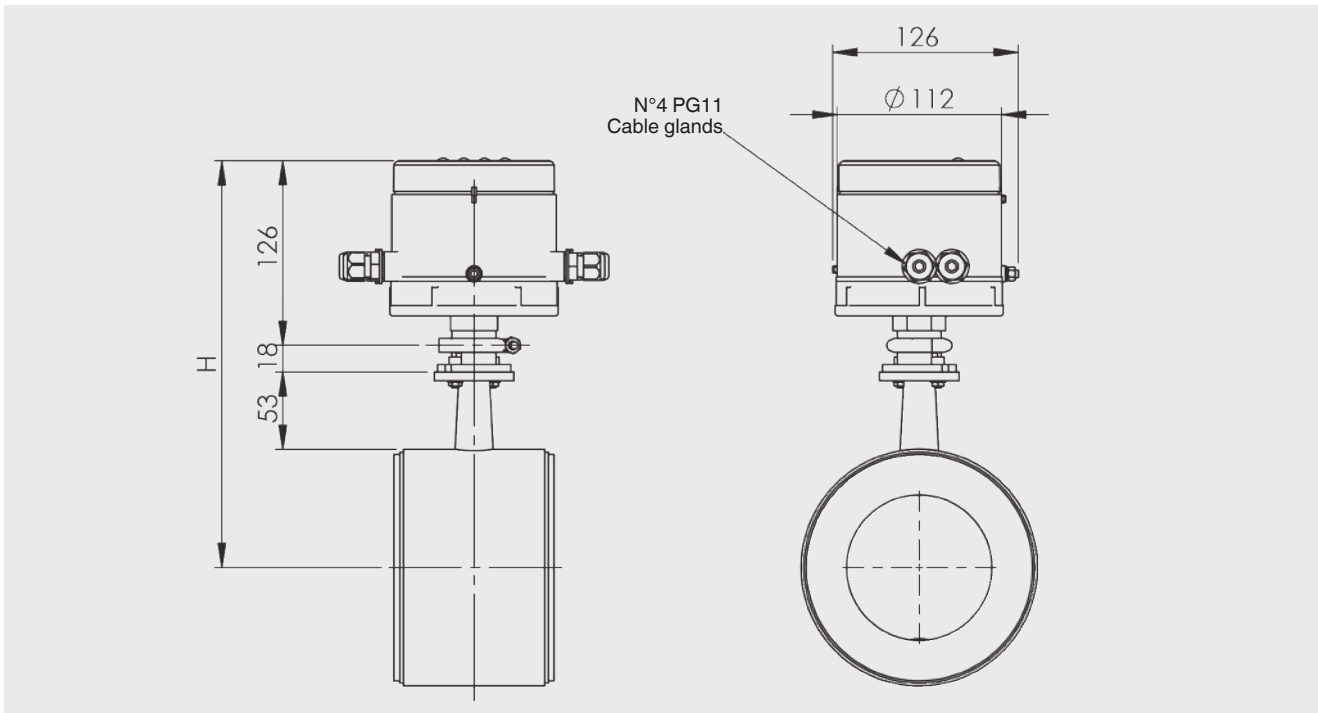

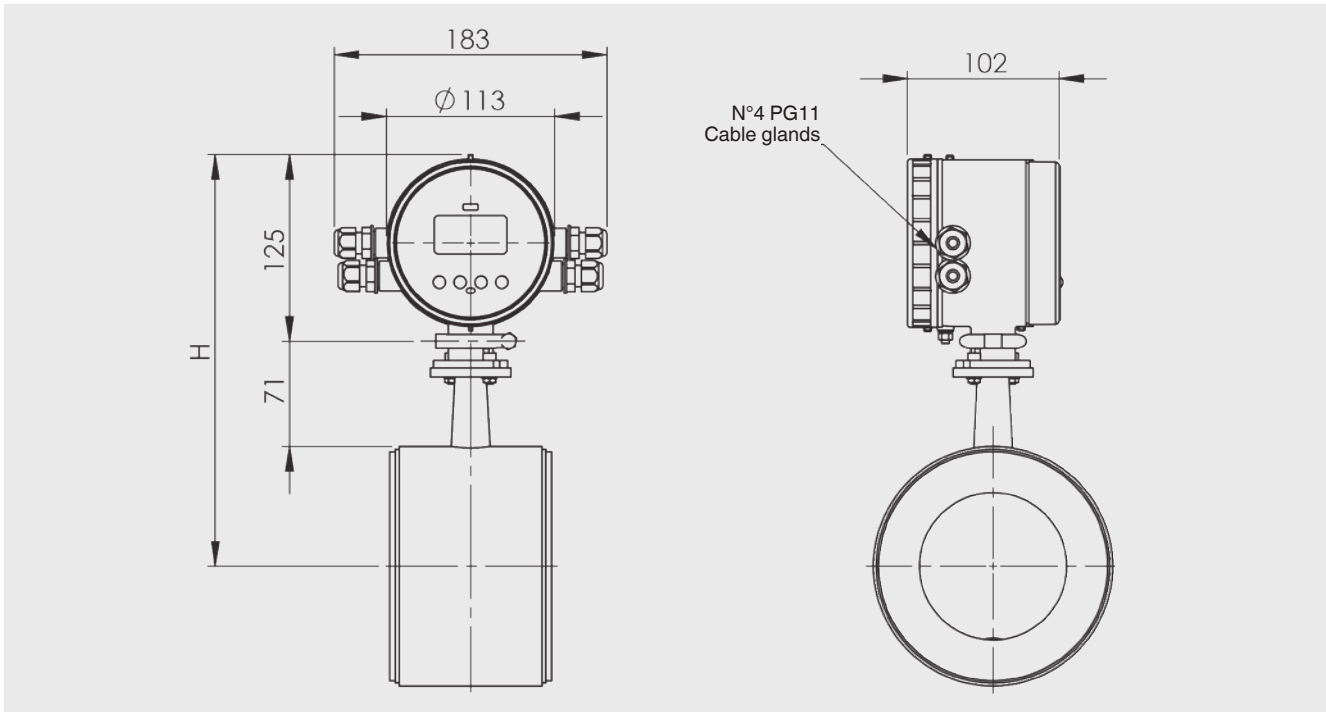

DN	H
25	234
32	239
40	241
50	248
65	254
80	261
100	278
125	290
150	305
200	331
250	357
300	383

Compact version: Model FLC-1000EL in combination with signal converter, model FLC-406, radial mount



DN	H
25	233
32	238
40	240
50	247
65	253
80	260
100	277
125	289
150	304
200	330
250	356
300	382

Approvals

Logo	Description	Country
	EU declaration of conformity	European Union
	EMC directive EN 61326 emission (group 1, class B) and immunity (industrial application)	
	Low voltage directive	
	ATEX directive (option for separated version)	
	IECEx (option for separated version)	International
-	Measuring instrument directive (MID)	European Union

Approvals and certificates, see website

© 07/2021 WIKA Alexander Wiegand SE & Co. KG, all rights reserved.
 The specifications given in this document represent the state of engineering at the time of publishing.
 We reserve the right to make modifications to the specifications and materials.

