

# Wake frequency calculation

WIKA data sheet IN 00.15

## Applications

- The wake frequency calculation for thermowells serves as mathematical proof of the strength with respect to static and dynamic stress in relation to the operating temperature and pressure

## Special features

- Wake frequency calculation per ASME PTC 19.3 TW-2016 for standard bar stock thermowells as an engineering service
- Recommendations for structural changes to the thermowell where the permissible stress limits are exceeded can be derived

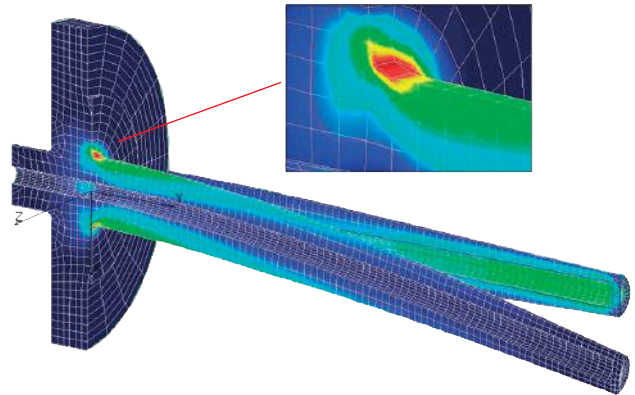

**FEA representation of a thermowell in flow with stress representation at the tip and at the root**

## Description

The wake frequency calculation per ASME PTC 19.3 TW-2016 is used for solid drilled bar stock thermowells in tapered, straight or stepped designs, such as models TW10, TW15, TW20, TW25 and TW30 or thermowells solid-machined from forgings.

The process data required to perform a calculation as per ASME PTC 19.3 TW-2016 is as follows:

	SI unit	Imperial	Others
Flow rate	m/s	ft/s	---
Density of medium	kg/m <sup>3</sup>	lb/ft <sup>3</sup>	---
Temperature	°C	°F	---
Pressure	bar	psi	---
Dynamic viscosity <sup>1)</sup>	mm <sup>2</sup> /s	ft/1000s	cP

1) Optional for ASME PTC 19.3 TW-2016

WIKA guarantees that the calculation is executed on the basis of the ASME PTC 19.3 TW-2016. The end user is responsible for the consistency between the real process data and the data on which the calculation is based. Generally, no warranty can be given by WIKA for the calculation of the results per ASME PTC 19.3 TW-2016. The results are of informative character.

For recommendations concerning structural changes where the permissible stress limits have been exceeded, the following additional information will also be required:

- Inside diameter of nozzle
- Height of nozzle (shielded length)
- Inner diameter and wall thickness of pipeline/vessel

## Basic information about ASME PTC 19.3 TW-2016

ASME PTC 19.3 TW-2016 is divided into dynamic and static calculation results.

For low density gases, the frequency limit is typically  $r_{max} = 0.8$ . For other gaseous medias, the steady operation in the range between  $r = 0.4 \dots 0.6$  around the in-line resonance is not permitted. For liquid media, in many applications, the newly-introduced limit frequency of  $r_{max} = 0.4$  for the in-line resonance typically applies.

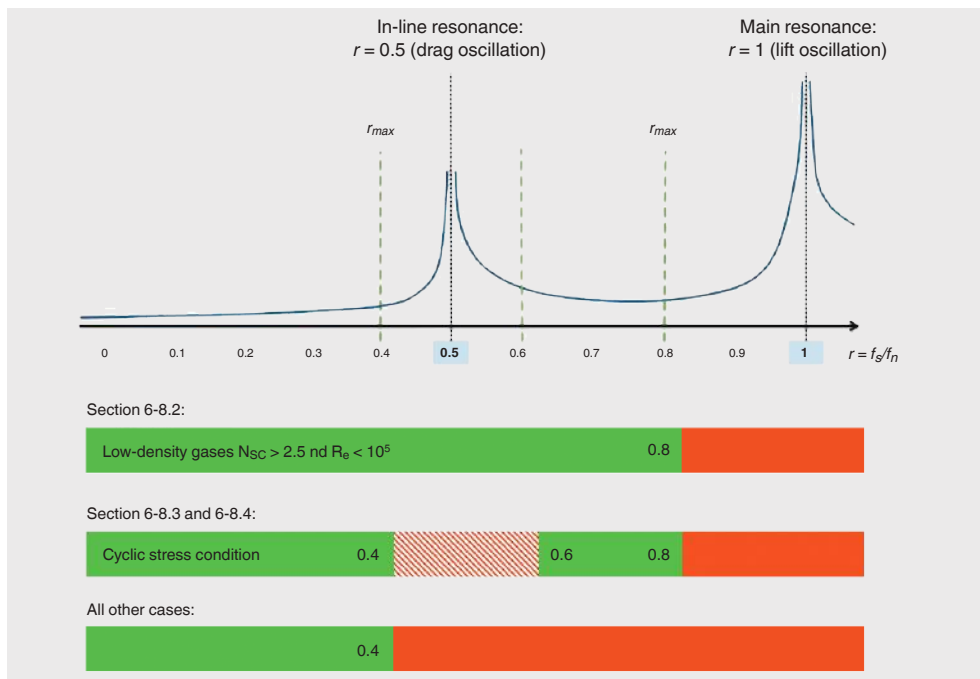

The evaluation of the dynamic results is made using the damping factor  $N_{SC}$  (the **Scruton Number**  $N_{SC}$  has a direct relationship to the permissible frequency ratio  $r_{max}$  from the wake frequency  $f_s$  to the natural frequency  $f_n$ ). Simplified, for gaseous media, a characteristic value is  $N_{SC} > 2.5$ ; fluids typically have an  $N_{SC} < 2.5$ .

The Scruton Number  $N_{SC}$  in the calculation is dependant on the intrinsic damping factor, the density of the thermowell material, the process medium and the tip and bore diameter of the thermowell.

Whether the frequency ratio,  $r < 0.8$ , can also be used as an evaluation limit with other process media, is determined through a consideration of the permissible stresses in the thermowell material with respect to the actual stresses at resonance. In addition, an evaluation of the strength of the thermowell material with respect to the flexural fatigue stress in the area of the thermowell clamping is carried out.

The static results of ASME PTC 19.3 TW-2016 are generated from the maximum permissible process pressure (dependent upon the process temperature and the geometry of the thermowell) and the bending stress in the area of the thermowell root. The bending stress is caused by the incident flow on the thermowell, and is dependent on the shielded length of the flange nozzle.

## Remedies using structural changes, when the permissible frequency ratio, $r_{\max}$ , is exceeded

By exceeding the maximum permissible limit frequency,  $r_{\max}$ , for the “In-line”- or main resonance, the following structural changes may be a solution:

### a) Shortening the insertion length

This is the most effective method (and the recommended method from ASME PTC 19.3 TW-2016) for the improvement of the frequency ratio  $r$ .

### b) Increasing the root diameter

By increasing the root diameter, the natural frequency  $f_n$  is increased, optimizing the frequency ratio  $r$ .

### c) Increasing the tip diameter

By increasing the tip diameter, the vortex shedding frequency  $f_s$  is reduced, optimizing the frequency ratio  $r$ .

### d) Support collars

Support collars or other means of support are outside the scope of the standard. The use of support collars is not generally recommended, as rigid support can be obtained only with an interference fit between the support collar and the installed piping, ASME PTC 19.3 TW-2016 points 6-7-(e). On customer request, support collars can be used, and are designed to provide an interference fit with the process connection. The thermowell will be designed in accordance with the design and calculation criteria of ASME PTC 19.3 TW-2016, however, this falls outside the scope of ASME PTC 19.3 TW-2016. The operator is responsible for the rigid support of the collar in the nozzle, which may mean that a reworking of the collar is needed. A guarantee for support collar solutions is generally not given by WIKA!

### e) ScrutonWell® design

The ScrutonWell® design can be used on solid-machined thermowells with flange connection, in Vanstone design or for weld-in or screwed process connection. This design reduces the amplitude of oscillation by more than 90 % <sup>1)</sup> and allows an easy and fast installation of the thermowell without expensive and time-consuming rework on site, at the same time. The WIKA ScrutonWell® design has been tested and approved by the independent laboratories TÜV SÜD NEL (Glasgow) and the Institute for Mechanics and Fluid Dynamics (Technical University of Freiberg).

For detailed information please see datasheet SP 05.16.

### Calculation of ScrutonWell® design based on ASME PTC 19.3 TW-2016

- Maximum permissible pressure load with original stem dimensions
- Maximum permissible bending load with modified stem dimensions
- The dynamic part of the wake frequency calculation is not required because of the damping of the oscillation by more than 90 %



Thermowell model TW10 in ScrutonWell® design

**For fabricated (welded tube) thermowells ASME PTC 19.3 TW-2016 is not applicable. Please contact a WIKA representative to provide calculations based on Dittrich/Klotter.**

1) Journal of Offshore and Mechanics and Arctic Engineering Nov 2011, Vol 133/041102-1 by ASME

# Performing a standard wake frequency calculation in accordance to ASME PTC 19.3 TW-2016

This simplified flow diagram shows the procedure of performing a standard wake frequency calculation in accordance to ASME PTC 19.3 TW-2016 step-by-step. The diagram addresses a failed frequency ratio only. Consult the WIKA operating instruction for a complete list of possible error codes.

Because of variation in thermowell designs in combination with various process parameters not all wake frequency calculations can follow this standard procedure.

If the illustrated procedure will not bring you to a good result, please contact your WIKA sales representative for support, because a individual engineered solution may be required.

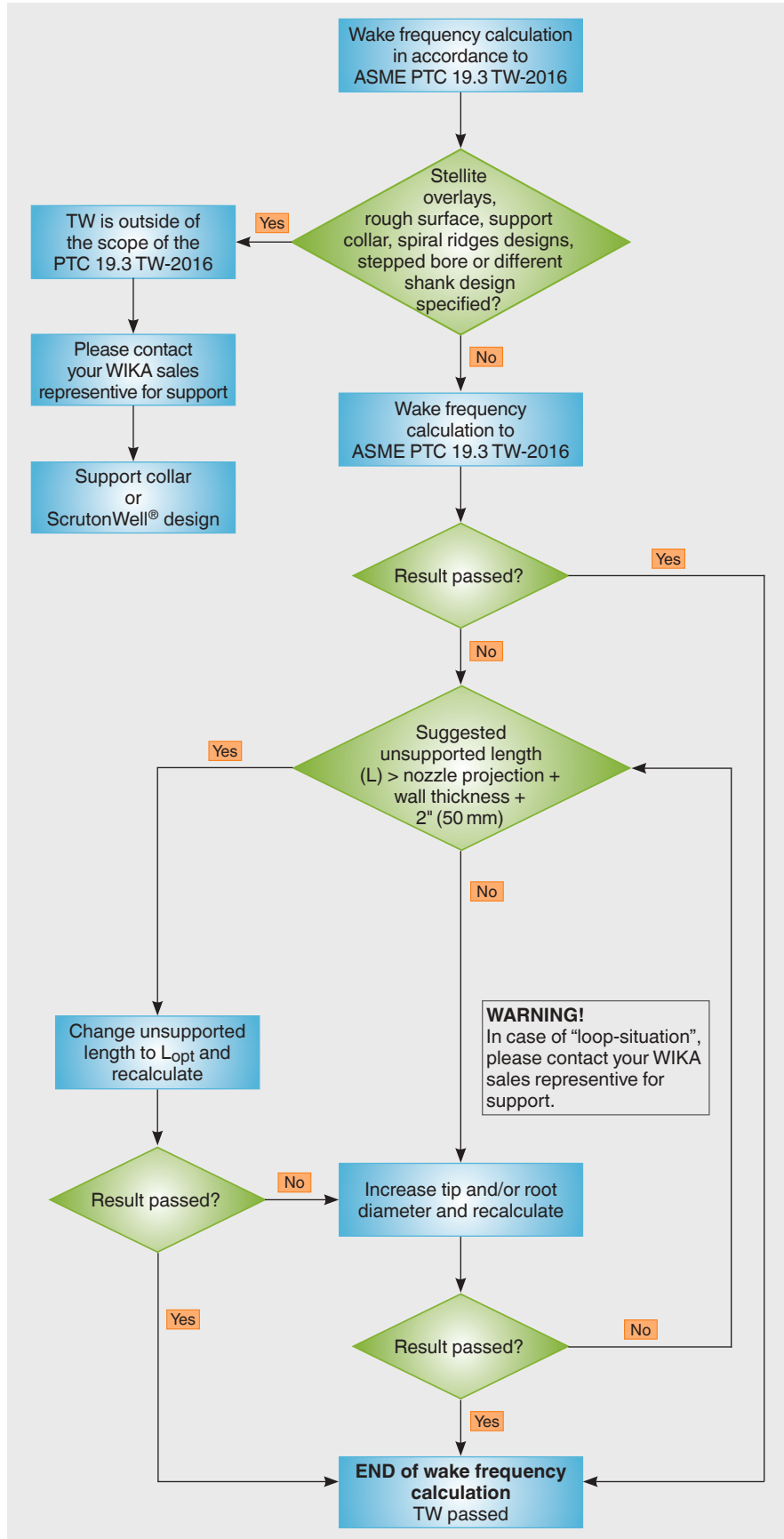

## Design details

### Determine 1st support collar location

The thermowell support collar location will be calculated as:  
Nozzle projection – 1" (25.4 mm)

For example:

14" (355.6 mm) nozzle projection. The 1st support collar would be located at 13" (330.2 mm) from the flange face.

The nozzle projection length is defined as the length from pipe/tube outside diameter to height of fitting (flange facing or sock-o-let, etc.).

Nozzle projection

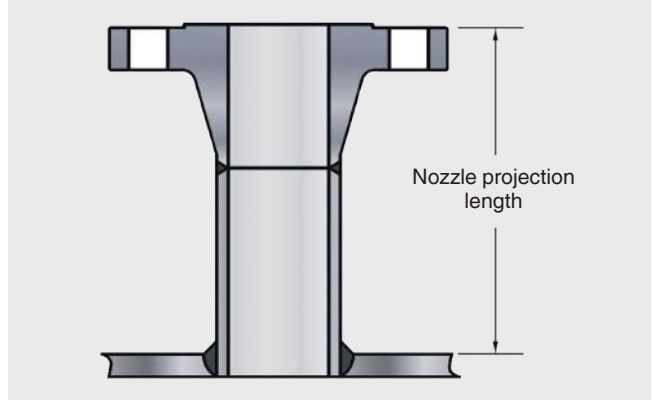

### Determine the number of support collars and locations

If the 1st support collar location is less than 5" (127 mm) only one support collar is required.

If the 1st support collar location is 5" (127 mm) or more, a 2nd support collar is required and located at 1st support collar location divided by two. For nozzle length greater than 30" (762 mm), please consult your WIKA sales representative.

#### Example No. 1 – Two support collars

Nozzle length is 14" (356 mm). Support collar 1 located at 14" (356 mm) – 1" (25.4 mm) = 13" (330 mm). Since this number is greater than 5" (127 mm), two support collars will be required. Therefore 13" (330 mm) / 2 = 6.5" (165 mm). Support collar 2 located at 6.5" (165 mm).

#### Example No. 2 – One support collar

Nozzle length is 4.5" (114 mm). Support collar 1 located at 4.5" (114 mm) – 1" (25.4 mm) = 3.5" (89mm). Since this number is smaller than 5" (127 mm), one support collar will be required.

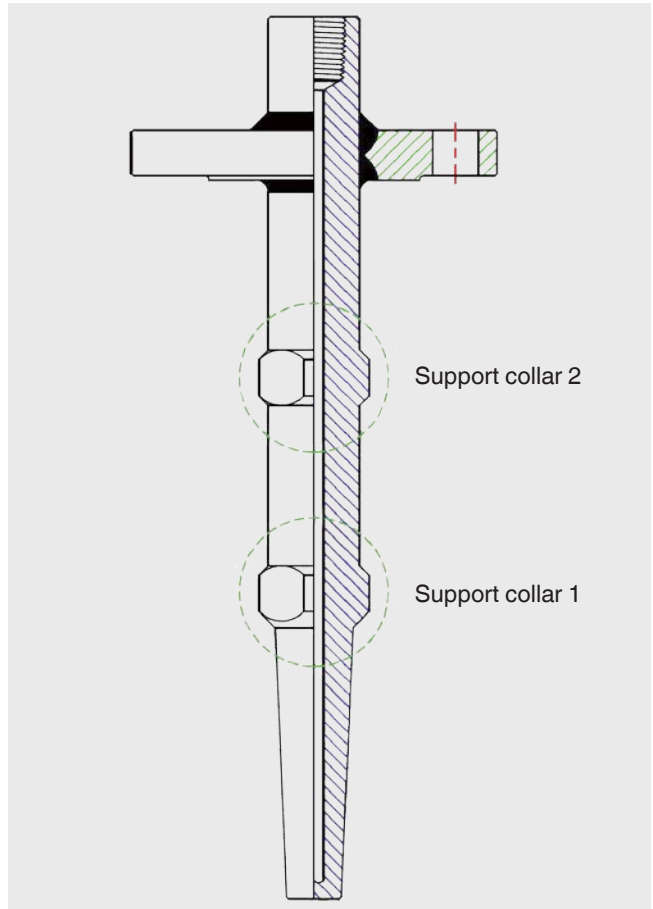

### Typical installation through a nozzle

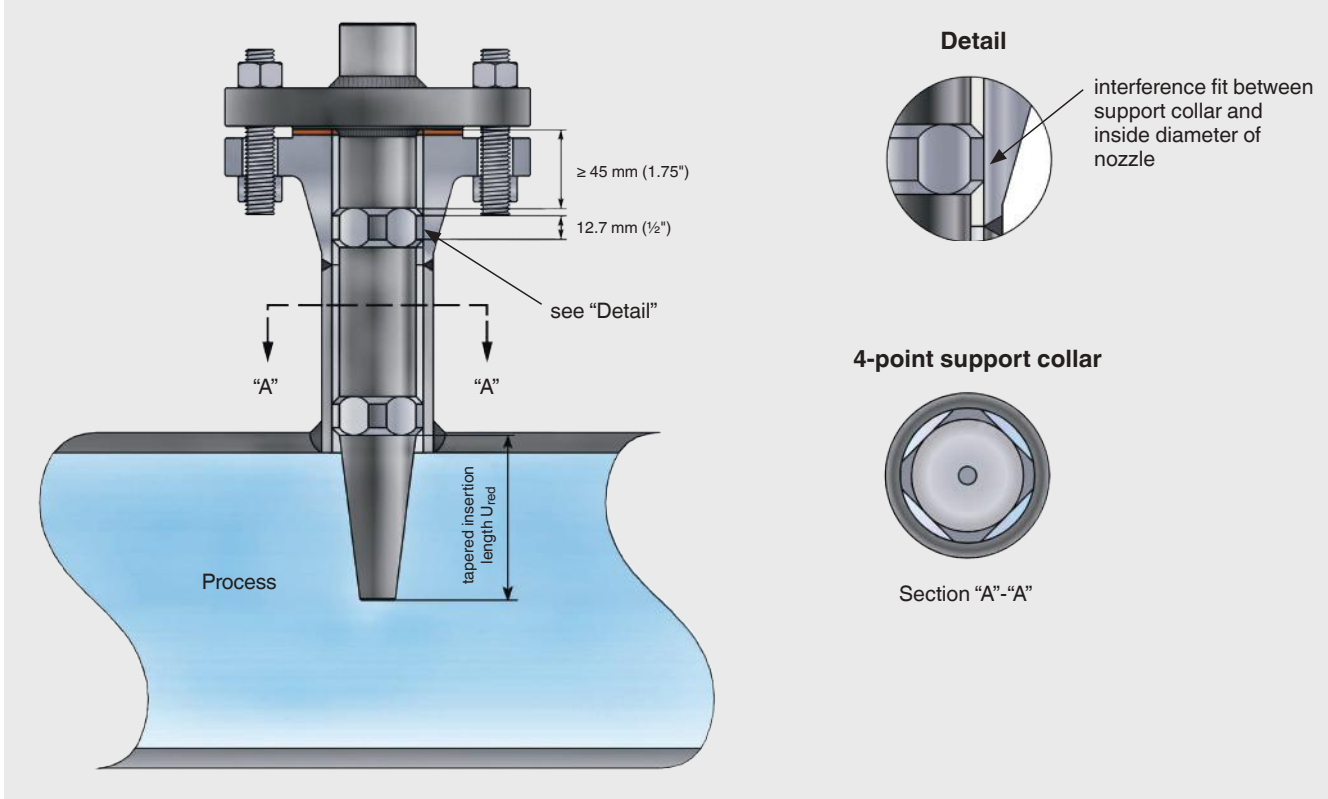

### Determine the support collar outside diameter from the pipe size and schedule

NPS	UOM	Outside diameter of support collar						
		SCH.10	SCH.40	SCH.STD	SCH.80	SCH.XS	SCH.160	SCH.XXS
1"	inch	1.107	1.059	1.059	0.967	0.967	0.825	0.609
	mm	28.1	26.9	26.9	24.6	24.6	21.0	15.5
1 1/2"	inch	1.692	1.620	1.620	1.510	1.510	1.348	1.110
	mm	43.0	41.1	41.1	38.4	38.4	34.2	28.2
2"	inch	2.167	2.077	2.077	1.949	1.949	1.697	1.513
	mm	55.0	52.8	52.8	49.5	49.5	43.1	38.4

### Determine the suggested maximum root diameter based on nozzle size and schedule

NPS	UOM	Suggested root diameter at support collar						
		SCH.10	SCH.40	SCH.STD	SCH.80	SCH.XS	SCH.160	SCH.XXS
1"	inch	0.938	0.875	0.875	0.813	0.813	0.688	0.500
	mm	23.8	22.2	22.2	20.6	20.6	17.5	12.7
1 1/2"	inch	1.500	1.375	1.375	1.250	1.250	1.125	1.000
	mm	38.1	34.9	34.9	31.8	31.8	28.6	25.4
2"	inch	1.875	1.750	1.750	1.625	1.625	1.500	1.250
	mm	47.6	44.5	44.5	41.3	41.3	38.1	31.8

## Design specifications to ASME PTC 19.3 TW-2016

Description	Tapered and straight designs		Stepped design	
	Minimum	Maximum	Minimum	Maximum
Insertion length L	63.5 mm (2.5")	609.6 mm (24")	127 mm (5")	609.6 mm (24")
Bore diameter d	3.175 mm (0.125")	20.9 mm (0.825")	6.1 mm (0.24")	6.7 mm (0.265")
Tip diameter B	9.2 mm (0.36")	46.5 mm (1.83")	-	-
Taper ratio B/A	0.58	1	-	-
Step ratio B/A for B = 12.7 mm	-	-	0.5	0.8
Step ratio B/A for B = 22.2 mm	-	-	0.583	0.875
Bore ratio d/B	0.16	0.71	-	-
Cross-sectional ratio L/B	2	-	2	-
Length ratio Ls/L	-	-	0	0.6
Min. wall thickness (B-D)/d	3 mm (0.12")	-	3 mm (0.12")	-

Marking	per ASME PTC 19.3 TW-2016	in WIKA data sheets
Insertion length	L	U
Bore diameter	d	B
Tip diameter	B	V
Root diameter	A	Q

If the thermowell dimensions, based on customer requirements or for specific applications, lie outside the requirements of ASME PTC 19.3 TW-2016, the calculation results can only be used for informative purposes. On these grounds, a guarantee cannot be given by WIKA.

## Provision of calculation data

The examples in the following table show how the process and geometry data should be provided as an excel spreadsheet for further electronic processing by WIKA.

### Sample table including calculation data for 6 measuring points

Tag no.	T	P	v	rho	Dyn. viscosity	Model	Dimensions in mm						Material (EN)	
	in °C	in bar	in m/s	in kg/m <sup>3</sup>	in cP		L	Ø d	Ø A	Ø B	Tt	NID		NL
TW-0301	220	1.5	23.6	2.4	0.013	TW10	250	8.5	25	19	6.4	38.3	220	1.4435
TW-0303	220	1.5	25.7	2.0	0.017	TW10	250	8.5	25	19	6.4	38.3	220	1.4435
TW-0305	235	10	19.6	6.1	0.015	TW10	250	8.5	25	19	6.4	38.3	220	1.4435
TW-0307	220	10	13	8.9	0.014	TW10	355	8.5	25	19	6.4	38.3	220	1.4571
TW-0309	235	30	8.9	28.3	0.013	TW10	355	8.5	25	19	6.4	38.3	220	1.4571
TW-0311	400	31.5	31.9	10.1	0.017	TW10	355	8.5	25	19	6.4	38.3	220	1.4571

#### Legend

Tag No.	Measuring point No.	L	Insertion length	NID	Nozzle inside diameter
T	Temperature	Ø d	Bore size	NL	Nozzle length
P	Pressure	Ø A	Root diameter	Model	WIKA thermowell model
v	Flow rate	Ø B	Tip diameter		
rho	Density of process medium	T <sub>t</sub>	Tip thickness		

© 03/2004 WIKA Alexander Wiegand SE & Co. KG, all rights reserved.  
The specifications given in this document represent the state of engineering at the time of publishing.  
We reserve the right to make modifications to the specifications and materials.

