

# Reed level transmitter for connection to WIKA radio unit

## Model FLRU

WIKA data sheet LM 20.13



for further approvals,  
see page 5

### Applications

- Condition-based and preventive maintenance through centralised big data analysis
- Chemical industry, petrochemical industry, natural gas, offshore, shipbuilding, machine building, power generating equipment, power plants, process water and drinking water treatment
- Level detection for almost all liquid media

### Special features

- IIoT-capable measuring instrument in combination with WIKA radio unit, model NETRIS®3
- Process- and procedure-specific solutions possible
- Operating limits:
  - Process temperature:  $T = -80 \dots +200 \text{ °C}$   
[ $-112 \dots +842 \text{ °F}$ ]
  - Operating pressure:  $P = \text{vacuum to } 80 \text{ bar [1,160 psi]}$
  - Limit density:  $\rho \geq 400 \text{ kg/m}^3$
- Wide variety of different process connections and materials
- Intrinsically safe version Ex i



### Level transmitter, model FLRU

### Description

The model FLRU level transmitter with reed-chain technology in combination with the WIKA model NETRIS®3 radio unit is used wherever web-based remote monitoring of level measurement in liquid media is desired. Condition-based and preventive maintenance through centralised big data analysis is thus possible.

Level transmitters of this model series work on the float principle with magnetic transmission and are used wherever centralised, web-based remote monitoring is required. The float's magnetic system in the guide tube actuates a resistance measuring chain that corresponds to a 3-wire

potentiometer circuit. The measurement voltage generated by this is proportional to the fill level.

The measurement voltage is very finely stepped due to the contact separation of the measuring chain and is thus virtually continuous. Depending on the requirements, several different contact separations are available.

The FLRU reed level transmitter is part of the WIKA IIoT solution. With this, WIKA offers a holistic solution for your digitalisation strategy.

**Installation example**

Model FLRU with WIKA radio unit, model NETRIS®3



# Specifications

Basic information	
Guide tube diameter	<ul style="list-style-type: none"> <li>■ 8 mm [0.32 in]</li> <li>■ 12 mm [0.42 in]</li> <li>■ 14 mm [0.55 in]</li> <li>■ 18 mm [0.71 in]</li> </ul>
Max. guide tube length L	<ul style="list-style-type: none"> <li>■ 500 mm [19.69 in] (guide tube diameter 8 mm [0.32 in])</li> <li>■ 1,500 mm [59.10 in] (guide tube diameter 12 mm [0.47 in])</li> <li>■ 3,500 mm [137.8 in] (guide tube diameter 14 mm [0.55 in])</li> <li>■ 6,000 mm [236.22 in] (guide tube diameter 18 mm [0.71 in])</li> </ul>
Overall resistance of the measuring chain	Depending on length and separation
Connection location	Lower mount
Float diameter	44 ... 120 mm [1.732 ... 4.724 in]

Accuracy specifications	
Resolution	<ul style="list-style-type: none"> <li>■ 2.7 mm [0.11 in]</li> <li>■ 5.5 mm [0.22 in]</li> <li>■ 7.5 mm [0.30 in]</li> <li>■ 9 mm [0.35 in]</li> </ul>
	Depending on contact separation
Mounting position	Vertical ± 30°

Process connection	
Standard	<ul style="list-style-type: none"> <li>■ DIN EN ISO 228-1</li> <li>■ EN 1092-1</li> <li>■ ASME B16.5</li> </ul>
Thread size	
DIN EN ISO 228-1	<ul style="list-style-type: none"> <li>■ G 1 ½, male thread</li> <li>■ G 2, male thread</li> </ul>
Mounting flange	
EN 1092-1	DN 50 ... DN 200, PN 6 ... PN 100
ASME B16	2" ... 8", Class 150 ... Class 600

Digital interface	
Signal type	Unified WIKA Interface (UWI)
Connection type	M12 x 1 circular connector (4-pin), B-coded, for use with WIKA radio unit model NETRIS®3

Material	
Material (wetted)	
Guide tube	<ul style="list-style-type: none"> <li>■ Stainless steel 1.4571 (316Ti)</li> <li>■ Stainless steel 1.4401 (316L)</li> <li>■ Stainless steel 1.4404 (316L)</li> <li>■ Stainless steel 1.4435 (316L)</li> </ul>
Float	<ul style="list-style-type: none"> <li>■ Stainless steel 1.4571 (316Ti)</li> <li>■ Buna</li> <li>■ Titanium</li> </ul>
Process connection	<ul style="list-style-type: none"> <li>■ Stainless steel 1.4571 (316Ti)</li> <li>■ Stainless steel 1.4401 (316L)</li> <li>■ Stainless steel 1.4404 (316L)</li> <li>■ Stainless steel 1.4435 (316L)</li> </ul>

Operating conditions		
Process temperature range	<ul style="list-style-type: none"> <li>■ -40 ... +120 °C [-40 ... +120 °F]</li> <li>■ -40 ... +200 °C [-40 ... +392 °F] (high-temperature version)</li> <li>■ -80 ... +120 °C [-112 ... +248 °F] (low-temperature version)</li> </ul>	
Ambient and storage temperature range	-40 ... +105 °C [-40 ... +221 °F]	
	Version with FKM O-ring -20 ... +105 °C [-4 ... +221 °F]	
Climate class per IEC 60654-1	Cx (-40 ... +105 °C [-40 ... +221 °F], 5 ... 95 % r. h.)	
	Version with FKM O-ring: -20 ... +105 °C [-4 ... +221 °F]	
Maximum permissible humidity, condensation	100 % r. h., condensation permissible	
Maximum operating pressure	80 bar [1,160 psi]	
Limit density	$p \geq 400 \text{ kg/m}^3$	
Salt mist	IEC 60068-2-11	
Vibration resistance	EN IEC 60721-3-2	Cl. 2M4
	EN IEC 60068-2-6	10 ... 55 Hz; 20 m/s <sup>2</sup> 10 frequency cycles per axis
Shock resistance per IEC 60068-2-27	<ul style="list-style-type: none"> <li>■ 50 g</li> <li>■ 6 ms</li> <li>■ 3 axes</li> <li>■ 3 directions</li> <li>■ 3 times in each direction</li> </ul>	
Ingress protection per EN IEC 60529 <sup>1)</sup>	<ul style="list-style-type: none"> <li>■ IP66</li> <li>■ IP68</li> </ul>	
Mounting position	Vertical $\pm 30^\circ$	

1) Ingress protection only applies with a correct plug connection with model NETRIS®3.

## Safety-related characteristic values (Ex)

Hazardous gas atmosphere	Temperature class	Ambient temperature range ( $T_a$ )	Process temperature
II 1G Ex ia IIC T1 - T6 Ga II 1/2G Ex ia IIC T1 - T6 Ga/Gb II 2G Ex ia IIC T1 - T6 Gb	T6	-40 ... +50 °C [-40 ... +122 °F]	-80 ... +72.5 °C [-112 ... +163 °F]
	T5	-40 ... +75 °C [-40 ... +167 °F]	-80 ... +87.5 °C [-112 ... +190 °F]
	T4	-40 ... +105 °C [-40 ... +221 °F]	-80 ... +122.5 °C [-112 ... +253 °F]
	T3	-40 ... +105 °C [-40 ... +221 °F]	-80 ... +187.5 °C [-112 ... +370 °F]
	T2	-40 ... +105 °C [-40 ... +221 °F]	-80 ... +200 °C [-112 ... +392 °F]
	T1	-40 ... +105 °C [-40 ... +221 °F]	-80 ... +200 °C [-112 ... +392 °F]

Hazardous dust/air atmospheres	Temperature class / maximum surface temperature	Ambient temperature range ( $T_a$ )	Process temperature
II 1D Ex ia IIIC * Da II 1/2D Ex ia IIIC * Da/Db II 2D Ex ia IIIC * Db	T135 °C	-40 ... +100 °C [-40 ... 212 °F]	-80 ... 200 °C [-112 ... +392 °F] - 9 K <sup>1)</sup>

1) Please take a self heating of 9 K into consideration.



The permissible ambient temperature for the respective category can be seen on the EU-type examination certificate and the certificate for hazardous areas or the operating instructions.

## Explosion protection

The permissible ambient temperature for the respective category can be seen on the EC-type examination certificate and the certificate for hazardous areas or the operating instructions.

## Approvals

Included in delivery

Logo	Description	Region
	<b>EU declaration of conformity</b> EMC directive EN 61326 emission (group 1, class B) and immunity (industrial application) RoHS directive	European Union
	ATEX directive Hazardous areas - Ex i Zone 0 gas II 1G Ex ia IIC T1 ... T6 Ga Zone 1 mounting to zone 0 gas II 1/2G Ex ia IIC T1 ... T6 Ga/Gb Zone 1 gas II 2G Ex ia IIC T1 ... T6 Gb Zone 20 dust II 1D Ex ia IIIC T135 °C Da Zone 21 mounting to zone 20 dust II 1/2D Ex ia IIIC T135 °C Da/Db Zone 21 dust II 2D Ex ia IIIC T135 °C Db	
	<b>IECEx - in combination with ATEX</b> Hazardous areas - Ex i Zone 0 gas Ex ia IIC T1 ... T6 Ga Zone 1 mounting to zone 0 gas Ex ia IIC T1 ... T6 Ga/Gb Zone 1 gas Ex ia IIC T1 ... T6 Gb Zone 20 dust Ex ia IIIC T135 °C Da Zone 21 mounting to zone 20 dust Ex ia IIIC T135 °C Da/Db Zone 21 dust Ex ia IIIC T135 °C Db	International

## Dimensions in mm [in]

### Process connection with parallel thread

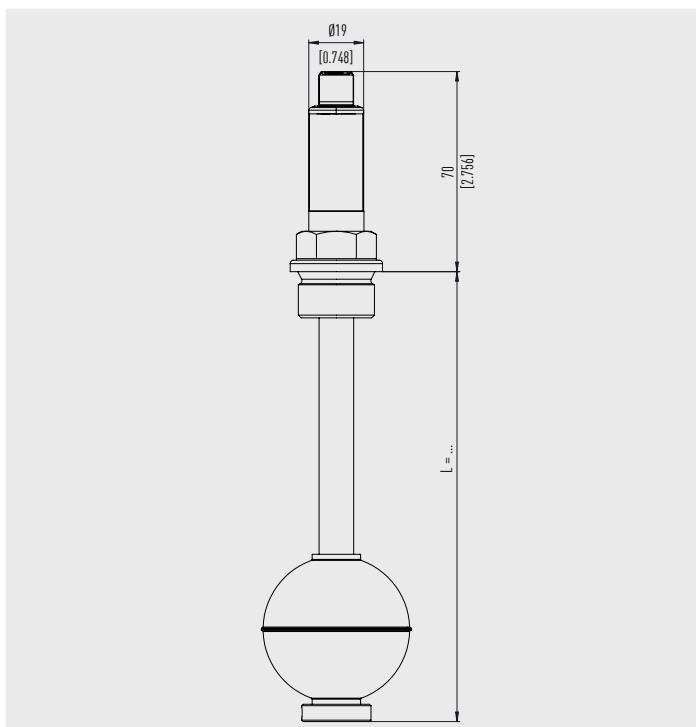

## Accessories

Description	Relevant data sheet	Further information
NETRIS®3 radio unit	AC 40.03	on request

## Ordering information

Model / Explosion protection / Process temperature / Process connection / Process pressure / Density / Insertion length L / Accessories / Certificates

© 04/2023 WIKA Alexander Wiegand SE & Co. KG, all rights reserved.  
The specifications given in this document represent the state of engineering at the time of publishing.  
We reserve the right to make modifications to the specifications and materials.

