

Rosemount 3155N Nuclear Qualified Pressure Transmitter

INDUSTRY LEADING PERFORMANCE

- Qualified per:
 - IEEE Std 323™ – 1974/1983/2003
 - IEEE Std 344™ – 1975/1987/2004
- 165 Mrad (1.65 kGy) TID Gamma Radiation
- 8.5g ZPA Seismic
- 437°F (225°C) Steam/Temperature
- 0.2% Reference Accuracy



Contents

Introduction.....	page 2
Transmitter Description	page 2
Operation.....	page 2
Dimensional Drawings	page 3
Nuclear Specifications.....	page 5
Performance Specifications	page 9
Functional Specifications	page 10
Physical Specifications.....	page 12
Ordering Information	page 16

Results Driven by Proven Measurement

Introduction

Rosemount 3155N Nuclear Pressure Transmitters are designed for precision pressure measurements in nuclear applications which require reliable performance and safety over an extended service life. The 3155N is qualified per IEEE Std 323™-1974/1983/2003 and IEEE Std 344™-1975/1987/2004 with radiation exposure to 165 Mrads TID gamma, seismic levels to 8.5g ZPA, and for steam pressure/temperature performance. Stringent quality control during the manufacturing process includes traceability of pressure-retaining parts, special nuclear cleaning, and hydrostatic testing.

Transmitter Description

Rosemount 3155N transmitters are similar in construction and performance to the proven Rosemount 3051 transmitters. Units are available in gauge (GP), and differential (DP) configurations, with five pressure range options. Direct electronic sensing with the completely

sealed coplanar capacitance sensing element (see Figure 1) minimizes mechanical force transfer and problems associated with shock and vibration. Installation and commissioning are simplified by compact design, 2-wire system compatibility, and non-interacting external span and zero adjustments for standard calibrations. The 3155N's dual compartment housing, a robust design which isolates the electronics from the wiring terminations, is also hermetically sealed and welded for added protection from severe environments including submergence.

Operation

Process pressure is transmitted through an isolating diaphragm and silicone oil fill fluid to a sensing diaphragm in the center of the sensor cell. Process or reference pressure is transmitted in a like manner to the other side of the center sensing diaphragm. The capacitor plates on both sides of the sensing diaphragm detect the position of the sensing diaphragm.

Figure 1 – The Sensor Cell

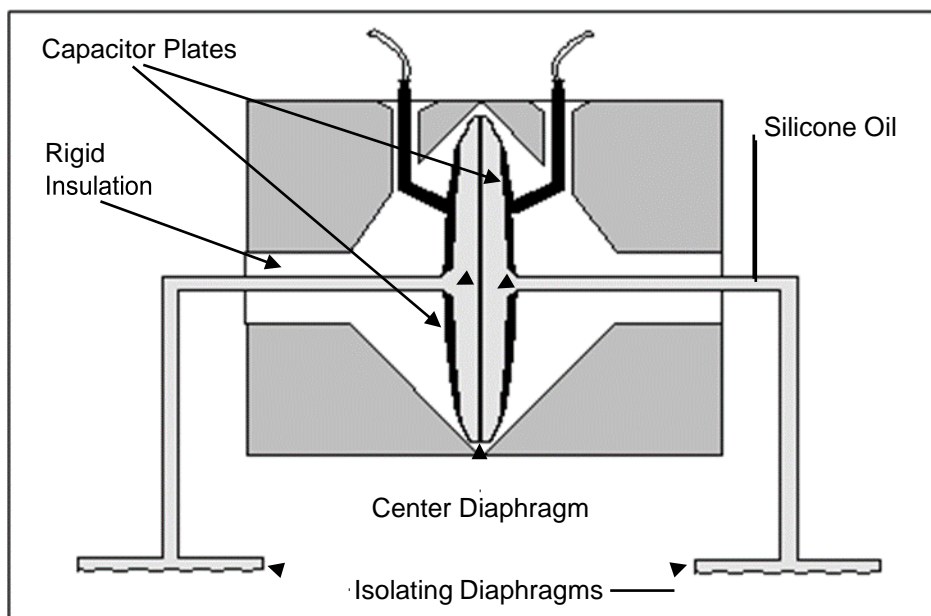
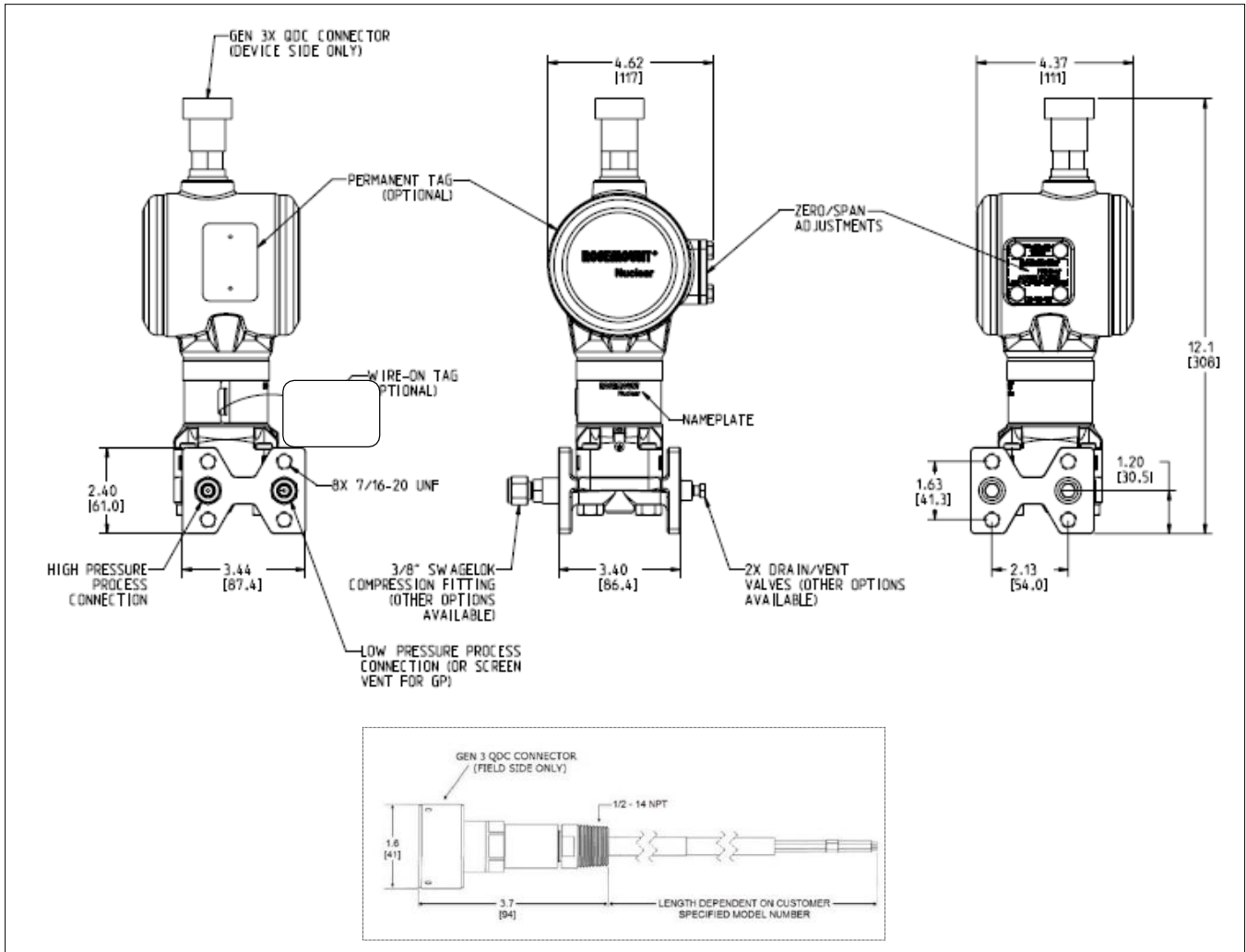
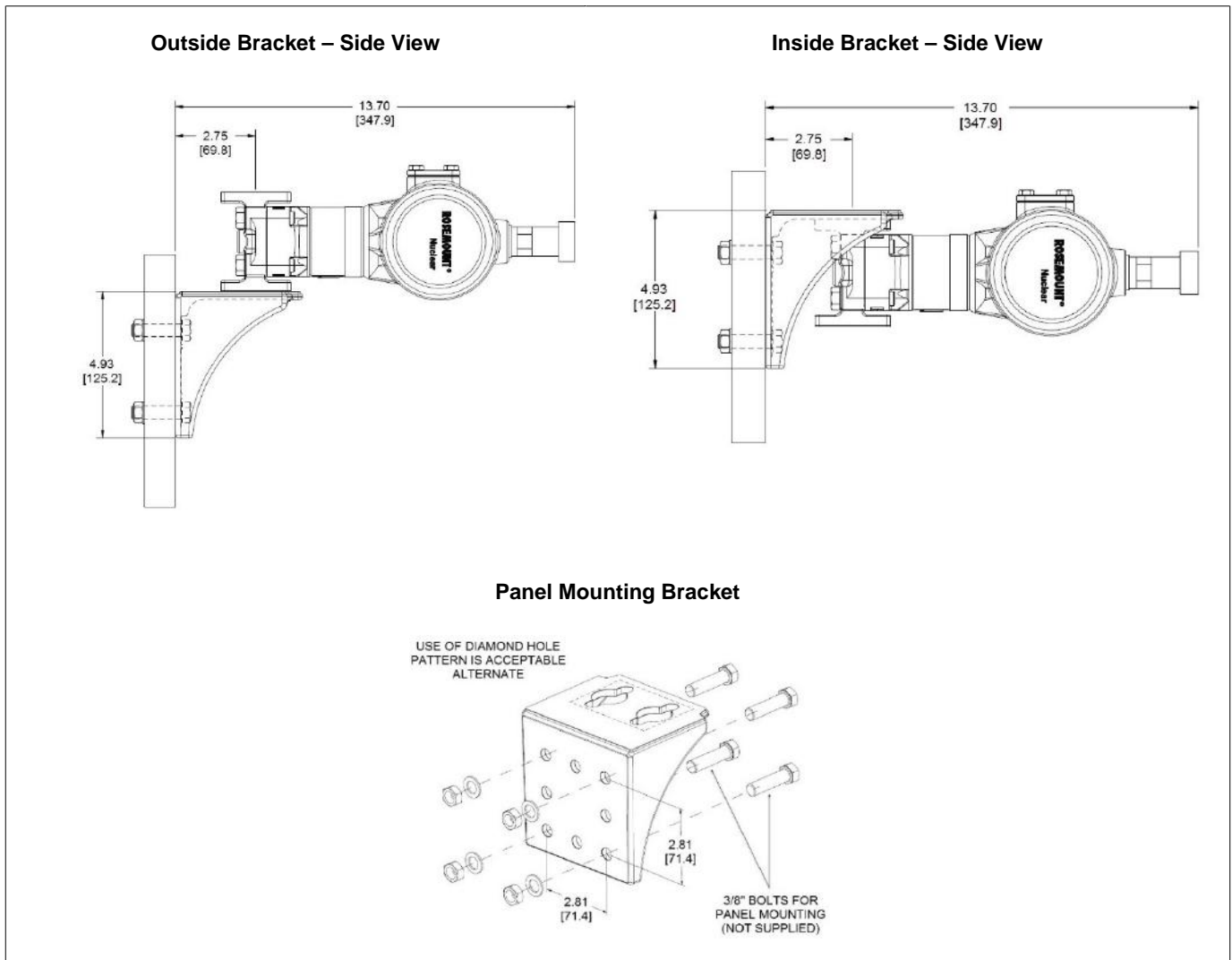

Figure 2a – Transmitter Dimensional Drawings
 Shown with EGS Gen 3 QDC Connector (Device Side Only)



- Note:
- (1) All dimensions are nominal in inches [millimeters].
 - (2) Field side of connector to be separately specified by customer.

Figure 2b – Typical Transmitter Mounting Configurations and Dimensions with Traditional Process Flange Panel Mounting Bracket



Note:

- (1) All dimensions are nominal in inches [millimeters].
- (2) Transmitter and bracket orientation with respect to gravity will not impact qualification.
- (3) Transmitter orientation with respect to bracket will affect center of gravity.
- (4) Transmitter can alternatively be mounted with the process connection positioned adjacent to the bracket (not shown).

SPECIFICATIONS

Nuclear Specifications

Qualified according to:
IEEE Std 323™ – 1974/1983/2003
IEEE Std 344™ – 1975/1987/2004
As documented in Rosemount Reports:
D2015008 and D2015009

Seismic

When exposed to a disturbance defined by the required response spectrum with a ZPA of 8.5g (see Figure 3), accuracies are as shown in the following table:

Range Code	Triaxial Random Multifrequency 8.5g ZPA	
	During	After
2	±0.5% URL	Within Reference Accuracy
3, 4	±0.3% URL	Within Reference Accuracy
5, 6	±0.2% URL	Within Reference Accuracy

Radiation

Exposed to a Total Integrated Dose (TID) of 167 Mrads (1.67 MGy), consisting of 2 Mrads (20 kGy) background radiation followed by 165 Mrads (1.65 MGy) accident radiation.

During and after initial exposure at a dose rate of 0.1 Mrads/hr (1 kGy/hr), accuracies are as shown in the following table:

Total Integrated Dose (TID)	Range Code	Background Radiation Effect
100 kRads	2 - 6	±(0.1% URL + 0.15% Span)
≤ 2 Mrads	2 - 6	±(0.25% URL + 1.25% Span)

For TID values greater than 100 kRads and less than 2 Mrads, the 3155N error specification for 100 kRads can be linearly extrapolated or, optionally, the specification for 2 Mrads can be applied. Example: At a TID value of 400 kRads, an error specification of 4 x [±(0.1% URL + 0.15% Span)] can be applied. Or conversely, the error specification for 2 Mrads can be applied.

When exposed to an additional Total Integrated Dose (TID) of 165 Mrads (1.65 MGy), consisting of 1.2 Mrads/hr for 2 hr, then a dose rate of 1.0 Mrads/hr until TID = 167 Mrads, accuracies are as shown in the following table:

Total Integrated Dose (TID)	Range Code	Accident Radiation Effect
≤ 60 Mrads	2 - 6	±(0.5% URL + 1.0% Span)
≤ 167 Mrads	2 - 6	±(1.0% URL + 1.0% Span)

Specification values for performance during accident radiation should not be linearly interpolated between radiation values.

Steam Pressure/Temperature and Post DBE Operation

During and after exposure to steam at the temperatures and pressures shown in Figure 4 and Figure 5, concurrent with chemical spray for the first 24 hours, accuracies are shown in the following tables:

LOCA:

Range Code	Steam Pressure/Temperature Effect
2 - 6	±(0.5% URL + 3.0% Span)

LOCA from t = 0 hours to t = 24.23 hours.

Post-Accident Monitoring in Submergence Environment:

Duration	Range Code	Submergence Effect
First 14 days	2 - 6	±(1.0% URL + 4.0% Span)
Entire 110 days	2 - 6	±(1.0% URL + 6.0% Span)

Post-Accident Monitoring in Steam Environment:

Range Code	Steam Pressure/Temperature Effect
2 - 6	±(1.0% URL + 6.0% Span)

Chemical Spray:

Chemical spray for 24 hours (spray was started within the first 14 – 30 minutes of the profile).

- During first hour: Deionized water with 2700 ppm B⁽¹⁾ with initial maximum pH of 4.50 at 77°F (25°C) (includes 10% margin on pH). Spray Rate: 0.15 gal/min/ft².
- During subsequent 23 hours: Deionized water with a minimum of 2428 ppm B⁽¹⁾, buffering agent 7.53 g/L Trisodium Phosphate Dodecahydrate (TSP), with a minimum pH of 8.58 – 8.64 at 77°F (25°C) (included 10% margin on pH). Spray Rate: 0.15 gal/min/ft².

Note:

(1) "B" represents Boron Concentration achieved by adding Boric Acid.

Figure 3 – Seismic Required Spectra (RRS)

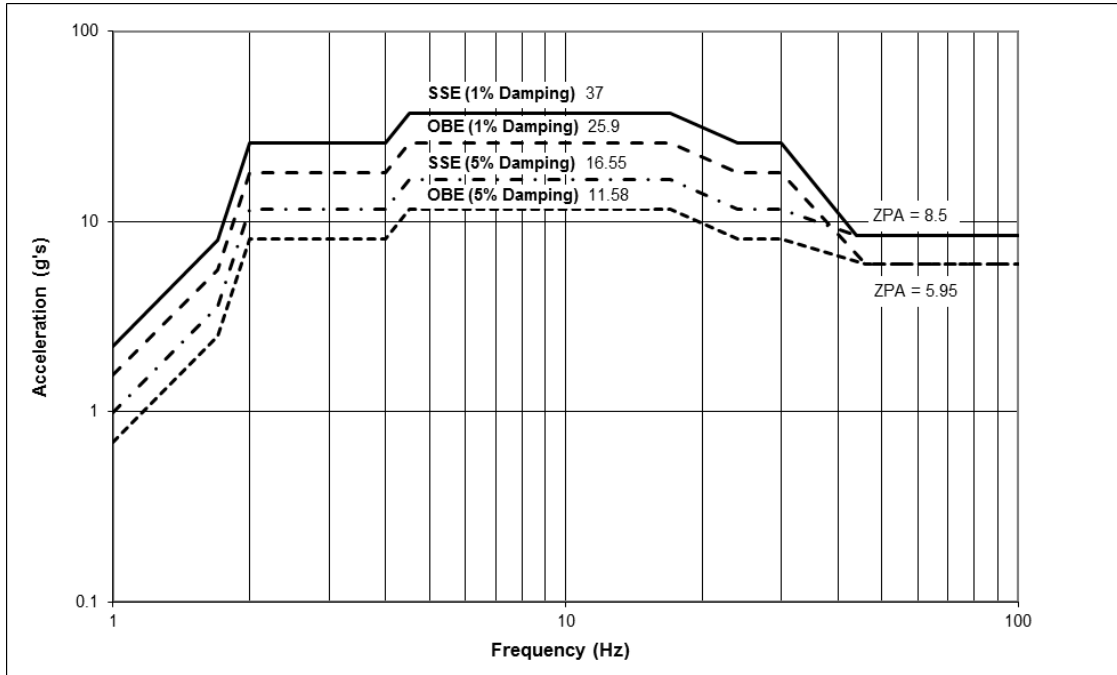
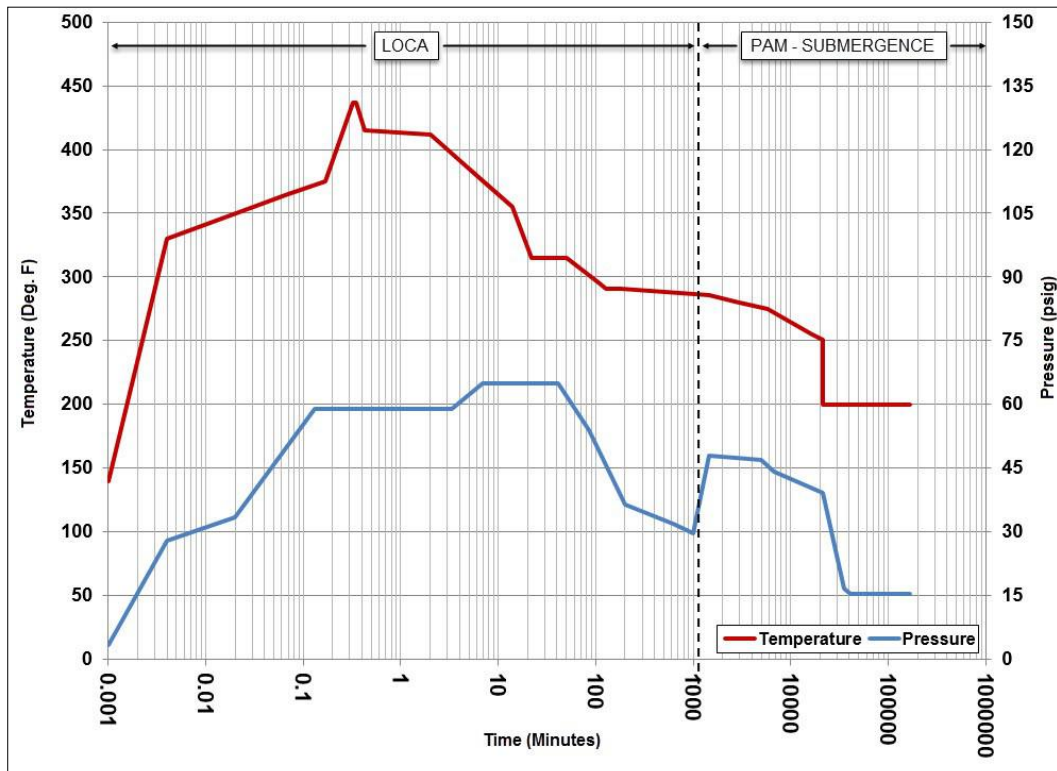

Figure 4 – Steam Pressure/Temperature and Post Accident Monitoring in Submergence Environment Profile



Note:

- (1) LOCA from t = 0 hours to t = 24.23 hours.
- (2) PAM - Submergence from t > 24.23 hours to t = 110 days.

Figure 5 – Steam Pressure/Temperature Post-Accident Monitoring in Steam Environment

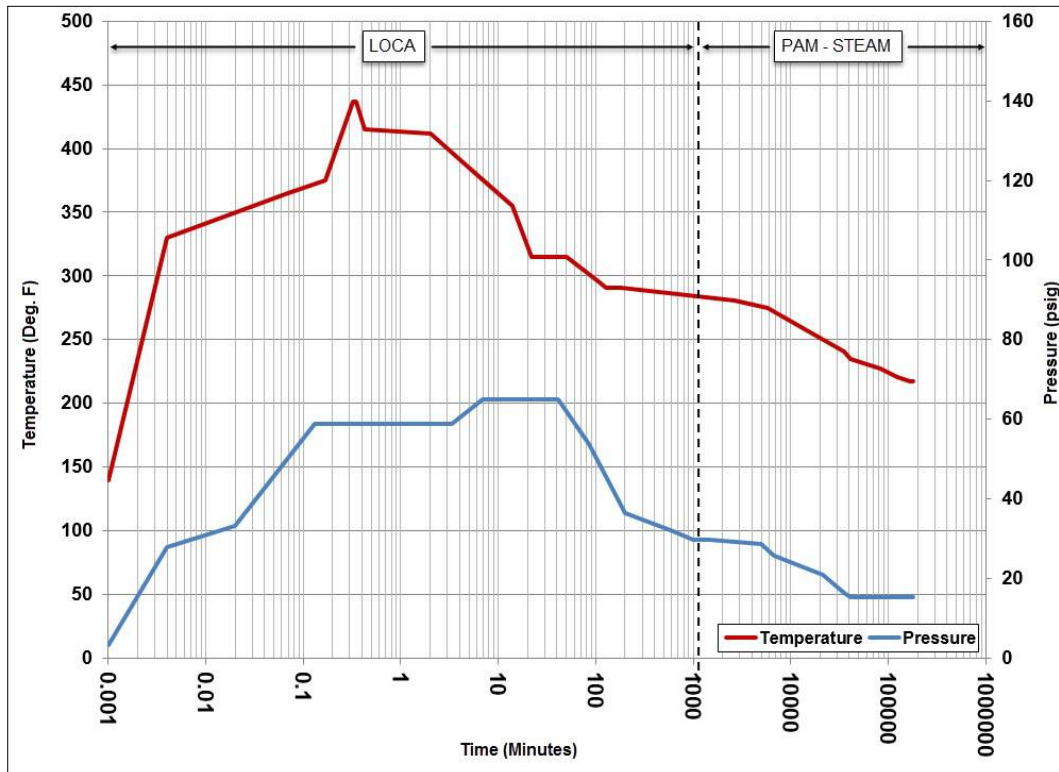

Note:

- (1) LOCA from $t = 0$ hours to $t = 24.23$ hours.
- (2) PAM - Steam from $t > 24.23$ hours to $t = 124.01$ days.
- (3) Chemical Spray from $t = 14$ minutes to $t = 24.23$ hours.

Nuclear Cleaning

Process wetted surfaces cleaned to < 1 ppm Chloride content.

Hydrostatic Testing

Hydrostatically tested to 150% of maximum working pressure for differential pressure transmitters and at the overpressure limit for gauge pressure transmitters.

Traceability

Per 10CFR50 Appendix B, NQA-1, and ISO 9001; chemical and physical certification of pressure retaining parts.

Qualified Life

10 years at 120°F (48.9°C) under typical operating conditions. Qualified Life is a function of Power Supply Voltage, Loop Load Resistance, and Operating Temperature. See Rosemount Qualification Reports D2015008 and D2015009 for application specific formulas.

Performance Specifications

Based on zero-based calibration spans under reference conditions.

Accuracy

Range Code	Reference Accuracy
2 - 5	±0.2% Calibrated Span
6	±0.25% Calibrated Span

Includes the effects of linearity, hysteresis, and repeatability.

Drift

Range Code	Drift Effect per 30 Months
2 - 6	±(0.1% URL + 0.1% Span)

Temperature Effect

Range Code	Temperature Effect (per 100°F (55.6°C) Temperature Shift)
2 - 6	±(0.15% URL + 0.6% Span)

This specification may be linearly interpolated down to 50 °F (27.8°C) temperature interval.

Overpressure Effect

Based on full overpressure limits:

- Range 2 – 5: 3626 psig (25.00 MPa)
- Range 6: 6000 psig (41.37 MPa)

3155ND:

Range Code	Overpressure Effect	
	One-Sided	Two-Sided Sequential
2, 3	±0.25% URL	±0.5% URL
4, 5	±0.3% URL	±2.0% URL

3155NG:

Range Code	One-Sided Overpressure Effect
2, 3	±0.25% URL
4 - 6	±0.3% URL

High Static Line Pressure Zero Effect (3155ND Only)

The High Static Line Pressure Zero Effect can typically be calibrated out by the customer (see 3155 Reference Manual 00809-0100-4855 for additional information). If it is not calibrated out, the error associated with the High Static Line Pressure Zero Effect is as follows:

For high static line pressure (Ps) less than or equal to 2000 psi (13.79 MPa):

Range Code	High Static Line Pressure Zero Effect Ps ≤ 2000 psi (13.79 MPa)
2 - 5	±0.1% URL per 1000 psi (6.89 MPa)

This specification may be linearly interpolated in 1000 psi (6.98 MPa) increments.

For high static line pressure (Ps) greater than 2000 psi (13.79 MPa):

Range Code	High Static Line Pressure Zero Effect Ps > 2000 psi (13.79 MPa)
2 - 5	±(0.2 + (0.2(Ps – 2000 psi)/1000 psi))% URL

This specification may be linearly interpolated in 1000 psi (6.89 MPa) increments.

High Static Line Pressure Span Effect (3155ND Only)

3155ND Ranges 2 and 3:

Range Code	High Static Line Pressure Span Effect per 1000 psi (6.89 MPa)
2, 3	±(0.1% URL + 0.1% Span)

3155ND Ranges 4 and 5:

Rosemount 3155ND ranges 4 and 5 experience a span shift when operated at high static line pressure. It is linear and typically correctable during calibration.

If no correction for the systematic High Static Line Pressure Span Effect is performed, the error is as follows:

Range Code	High Static Line Pressure Span Effect Error per 1000 psi (6.89 MPa)
4	-1.0% ± 0.2% Input Reading
5	-1.25% ± 0.2% Input Reading

If the correction procedure as outlined in the 3155 Reference Manual 00809-0100-4855 is applied, the remaining correction uncertainty for the High Static Line Pressure Span Effect for ranges 4 and 5 is as follows:

Range Code	High Static Line Pressure Span Correction Uncertainty per 1000 psi (6.89 MPa)
4, 5	±0.2% Input Reading

It is possible to improve the accuracy of the 3155ND at high static line pressure for applications requiring enhanced performance. Please contact Rosemount Nuclear Instruments, Inc. for additional information.

Power Supply Effect

Less than 0.005% of span / volt

Load Effect

Less than 0.0001% of span / ohm based on resulting change in terminal voltage to the transmitter.

Electromagnetic Compatibility

Satisfies requirements defined in:

- US NRC Regulatory Guide 1.180 Rev. 1
- EN 61326-1:2006 and EN 61326-2-3:2006

Mounting Position Effect

No span effect; zero shift of up to 1.5 inH₂O (0.37 kPa) which can be calibrated out.

Functional Specifications

Service

Liquid, gas, vapor

Output

4 – 20 mA

Power Supply

Maximum qualified supply voltage:
48 VDC

Maximum allowable supply voltage ripple:
Less than 1 volt peak-to-peak ripple for ripple frequency less than or equal to 120 Hz.

Load Limits

See Figure 6

Dielectric Withstand Test

707 VDC, 60 seconds, leakage less than 1 mA

Insulation Resistance Test

500 VDC, 60 seconds, IR greater than 100 Mohm

Figure 6 – Transmitter Load Limits vs. Power Supply Voltage

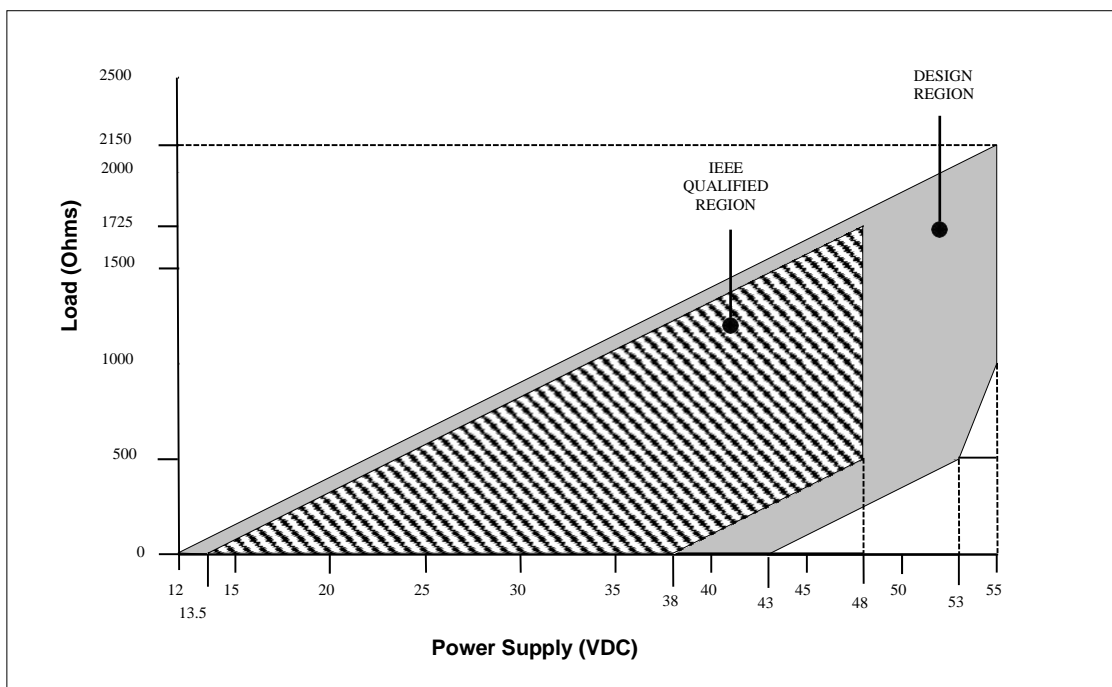

Span and Zero Adjustments

External adjust; non-interacting for standard adjustments

Zero Elevation, Zero Suppression

Maximum Zero Elevation

Zero is adjustable to the Lower Range Limit (LRL)⁽¹⁾ ⁽²⁾

Maximum Zero Suppression

Zero is adjustable to 90% of the Upper Range Limit (URL)⁽²⁾

Note:

- (1) Lower Range Limit (LRL) values are listed in the Ordering Information Table on page 16.
- (2) Rosemount 3155N calibration values must be set at the factory during manufacturing. The all-welded design does not allow for major zero elevation or suppression adjustments to the transmitter calibration after manufacturing.

Range Down

10:1

Response Time

Time constant (63.2%) at 100°F (37.8°C)

Range Code	Fixed Time Response (Max) DP / GP
2	0.5 sec
3 - 6	0.2 sec

Temperature Limits

Normal Operating Limits: 40°F to 200°F (4.4°C to 93.3°C)

Qualified Storage Limits: -40°F to 140°F (-40.0°C to 60°C)

Humidity Limits

0 to 100% relative humidity (NEMA 4X)

Enclosure Rating

NEMA 4X (IP 66)

Volumetric Displacement

Less than 0.005 in³ (0.082 cm³)

Turn-On Time

2 seconds maximum

Maximum Working Pressure

Larger of Static Pressure Limit or Upper Range Limit (URL)

Pressure Ranges

Adjustable within the range shown⁽¹⁾; Upper Range Limit (URL) is the highest pressure shown

3155ND and 3155NG:

Range Code	Pressure Range
2	0-25 to 0-250 inH ₂ O (0-6.23 to 0-62.3 kPa)
3	0-100 to 0-1000 inH ₂ O (0-24.9 to 0-249 kPa)
4	0-30 to 0-300 psi (0-206.8 to 0-2068 kPa)
5	0-200 to 0-2000 psi (0-1.38 to 0-13.79 MPa)
6 ⁽²⁾	0-400 to 0-4000 psi (0-2.76 to 0-27.58 MPa)

Note:

- (1) Rosemount 3155N calibration values must be set at the factory during manufacturing. The all-welded design does not allow for major zero elevation or suppression adjustments to the transmitter calibration after manufacturing.
- (2) Range 6 is not available on 3155ND.

Static Line Pressure Limits (3155ND Only)

Range Code	Static Pressure Limit
2 - 5	0.5 psia to 3626 psig (3.45 kPa to 25.00 MPa)

Overpressure Limits

Range Code	Overpressure Limit
2 - 5	3626 psig (25.00 MPa)
6	6000 psig (41.37 MPa)

Burst Pressure

Minimum burst pressure is 10,000 psig (68.95 MPa)

Physical Specifications

Materials of Construction

Number in parenthesis indicate where part is located in Figure 7.

Isolating Diaphragms (10)

316L SST

Drain/Vent Valves (12)

316L SST

Process Flanges (12)

CF3M (cast version of 316L SST)

Process Seal (C-rings) (11)

Silver-plated InconeI™ X-750

Zero/Span Cover (8)

316 SST

Zero/Span Bolts (9)

316 SST

Zero/Span Cover Seal (7)

Silver Jacket, Alloy 90 Spring

Fill Fluid (10)

Silicone Oil

Sensor Module Housing (10)

CF3M (cast version of 316L SST)

Flange Bolts (14)

316 SST

Electronics Housing (4)

CF3M (cast version of 316L SST)

Mounting Bracket (15)

CF8M (cast version of 316 SST)

Mounting Bolts (bracket to transmitter) (17)

17-4 PH SST

Process Connections

1/4 - 18 NPT (per EN 61518 / IEC 61518); 1/4 Swagelok® or 3/8 Swagelok®

Electrical Connections

Integral welded device side electrical connector:
EGS QDC Generation 3

Weight

- 17.1 lbs. (7.8 kg) (excluding bracket)
- 22.3 lbs. (10.1 kg) (including SST panel mounting bracket)

Figure 7 – Parts Drawing and Table, Exploded View

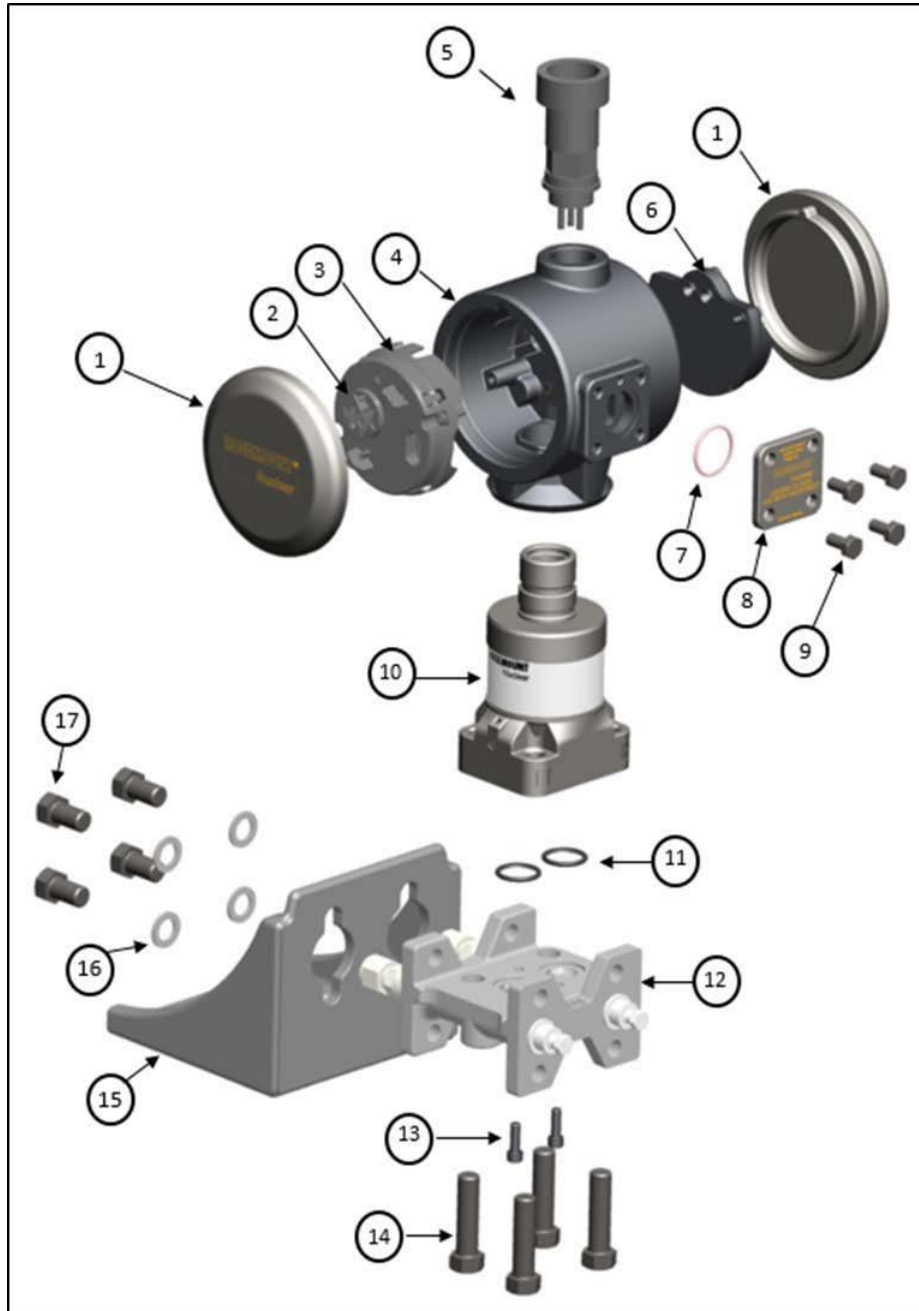

ITEM #	DESCRIPTION	ITEM #	DESCRIPTION
1	Electronics Cover	10	Sensor Module
2	Coarse Zero Select Jumper	11	C-rings for Process Flange
3	Electronics Assembly	12	Process Flange
4	Electronics Housing Assembly (includes set screws)	13	Flange Cap Screws
5	EGS Gen 3 Connector (device side only)	14	Bolts for Process Flange
6	Terminal Block Assembly	15	Mounting Bracket
7	Zero/Span C-ring	16	Washers
8	Zero/Span Cover	17	Bolts for Mounting Bracket
9	Zero/Span Bolts		

Figure 8 – Electrical Block Diagram

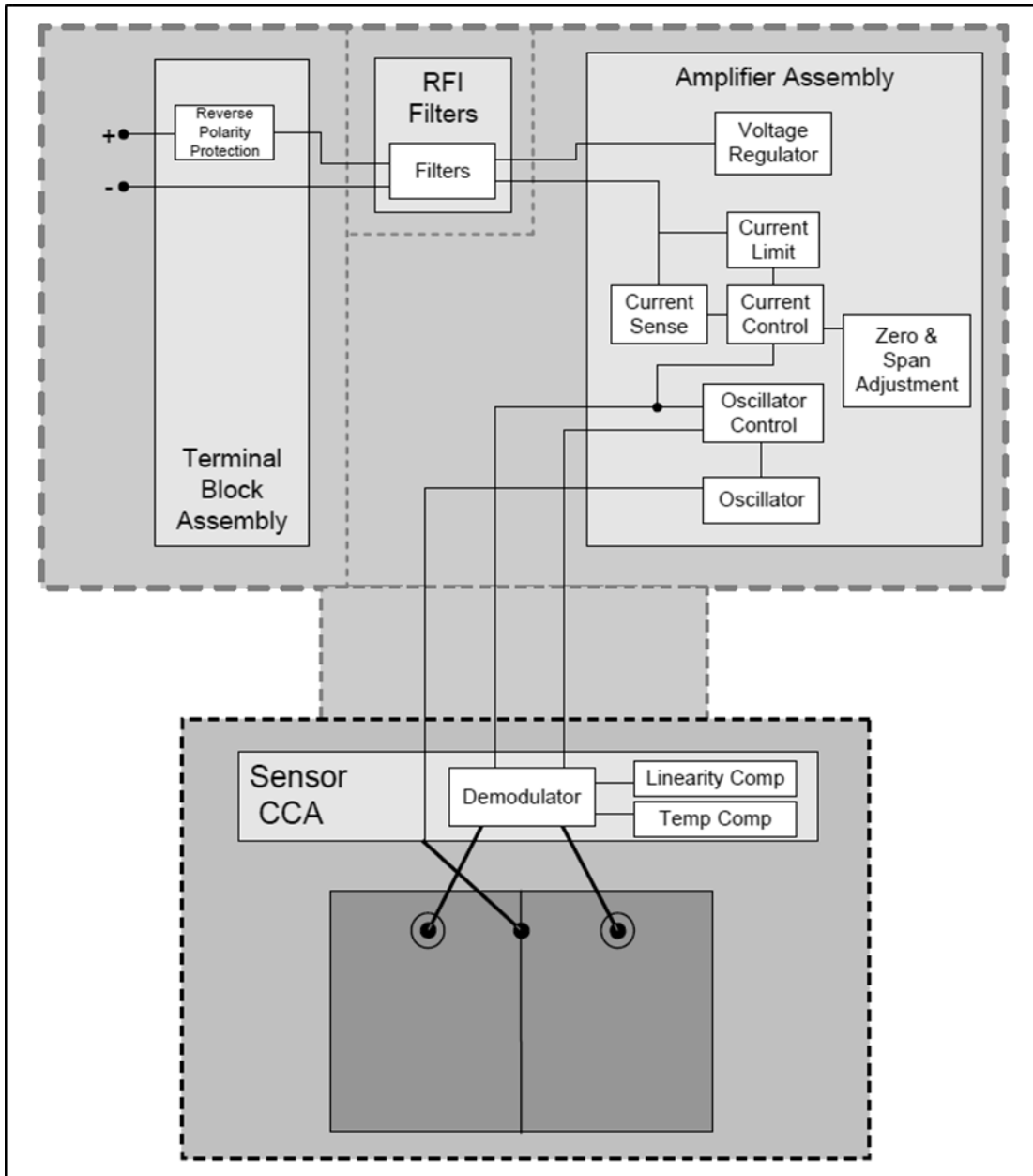
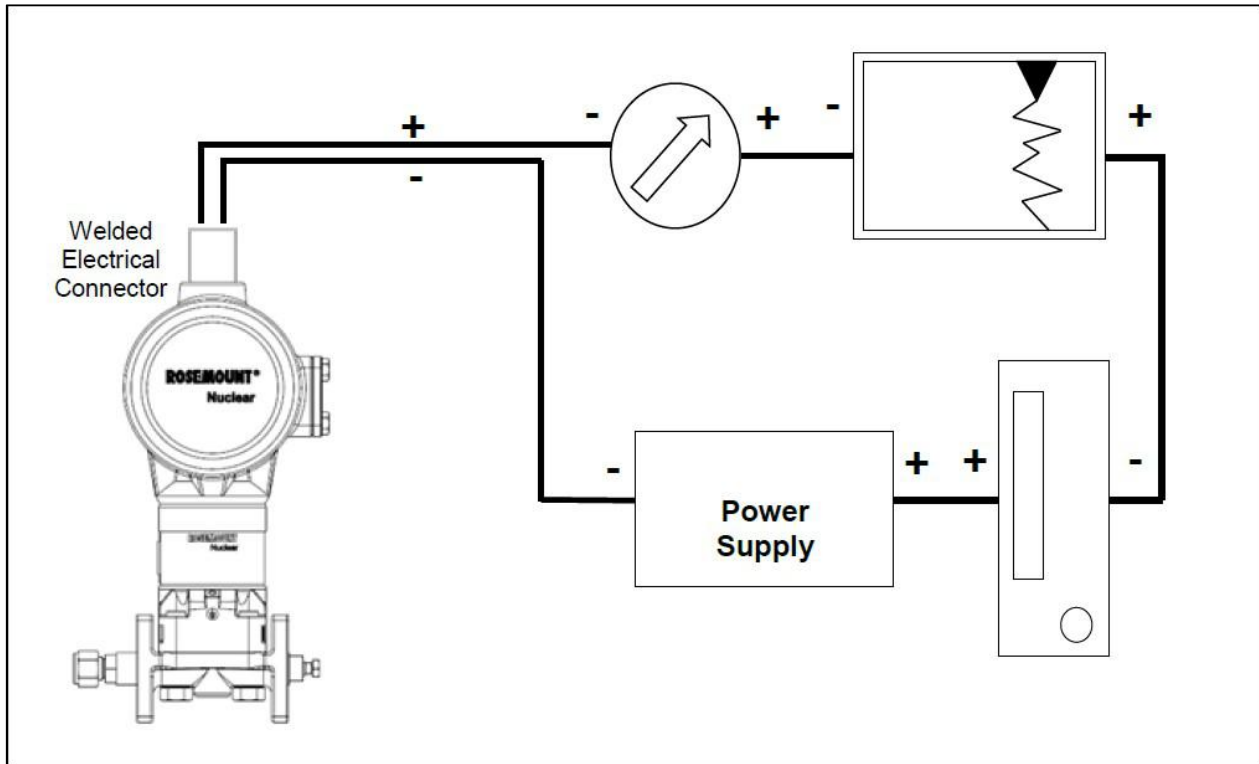
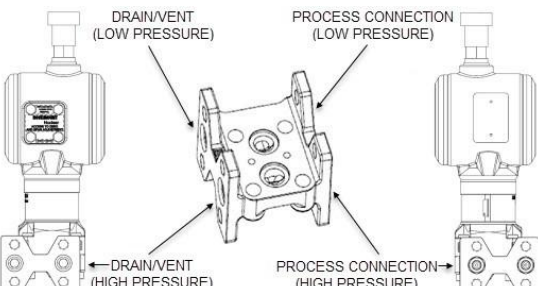
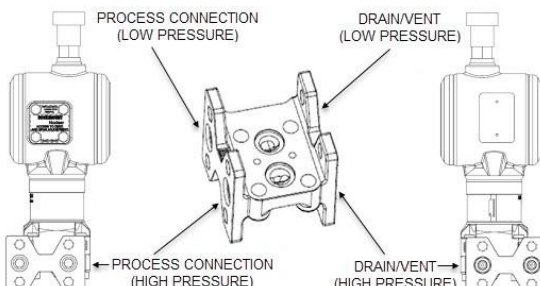

Figure 9 – Typical Transmitter Wiring Connection



ORDERING INFORMATION

Model	Transmitter Type			
3155ND	Nuclear Differential Pressure Transmitter			
3155NG	Nuclear Gauge Pressure Transmitter			
PRESSURE RANGES ⁽¹⁾				
Code	Differential <i>Lower Range Limit (LRL) to Upper Range Limit (URL) / Minimum Span</i>		Gauge ⁽²⁾	
2	-250 to 250 inH ₂ O / 25 inH ₂ O (-62.3 to 62.3 kPa/6.23 kPa)		-250 to 250 inH ₂ O / 25 inH ₂ O (-62.3 to 62.3 kPa/6.23 kPa)	
3	-1000 to 1000 inH ₂ O / 100 inH ₂ O (-249 to 249 kPa/24.9 kPa)		-393 to 1000 inH ₂ O / 100 inH ₂ O (-97.9 to 249 kPa/24.9 kPa)	
4	-300 to 300 psi / 30 psi (-2068 to 2068 kPa/206.8 kPa)		-14.2 to 300 psig / 30 psi (-97.9 to 2068 kPa/206.8 kPa)	
5	-2000 to 2000 psi / 200 psi (-13.79 to 13.79 MPa/1.38 MPa)		-14.2 to 2000 psig / 200 psig (-97.9 kPa to 13.79 MPa/1.38 MPa)	
6	N/A		-14.2 to 4000 psig / 400 psig (-97.9 kPa to 27.58 MPa/2.76 MPa)	
Code	Transmitter Output			
R	Harsh Environment; 4 – 20 mA Analog			
Code	Isolating Diaphragm			
2	316L SST			
Code	Process Flange Type / Material	Process Connection	Vent / Drain	Orientation
F0	Traditional / SST (meets EN 61518 / IEC 61518)	1/4 – 18 NPT ⁽³⁾	1/4 – 18 NPT Drain Hole ⁽³⁾	See Figure A
F1	Traditional / SST (meets EN 61518 / IEC 61518)	1/4 – 18 NPT ⁽³⁾	Welded Vent/Drain Valve	See Figure A
F2	Traditional / SST	Welded 3/8 inch Swagelok®	1/4 – 18 NPT Drain Hole ⁽³⁾	See Figure A
F3	Traditional / SST	Welded 3/8 inch Swagelok®	Welded Vent/Drain Valve	See Figure A
F4	Traditional / SST	Welded 3/8 inch Swagelok®	Welded 3/8 inch Swagelok®	See Figure A
F5	Traditional / SST (meets EN 61518 / IEC 61518)	1/4 – 18 NPT ⁽³⁾	Welded Vent/Drain Valve	See Figure B
F6	Traditional SST	Welded 1/4 inch Swagelok®	1/4 – 18 NPT Drain Hole ⁽³⁾	See Figure A
F7	Traditional SST	Welded 1/4 inch Swagelok®	Welded Vent/Drain Valve	See Figure A
F8	Traditional SST	Welded 1/4 inch Swagelok®	Welded 1/4 inch Swagelok®	See Figure A
S2	Remote Seal, Two Sided	See 3159 Product Data Sheet (00813-0100-4859)	See 3159 Product Data Sheet (00813-0100-4859)	N/A
 <p>FIGURE A</p>		 <p>FIGURE B</p>		

Continued on Next Page

Code Electrical Housing, Conduit Connection	
J	SST, Welded
Code Mounting Bracket	
0	No Bracket
2	Traditional Process Flange Bracket, SST Panel
Code Electrical Connector	
CP	Welded Connector, EGS QDC Generation 3 (Device Side Only) ^{(4) (5)}
Code Standard Options	
PA	Extended 30 Minute Hydrostatic Test (Standard Hydrostatic Test Completed on Every Transmitter is 10 Minutes in Duration)
P4	Calibration at Static Line Pressure ⁽⁶⁾
P5	Process Seal Helium Leak Test
P6	Extended Upper Range Limit ⁽⁷⁾
P8	Time Response Test
Q6	25-Point Reference Accuracy Test
Q8	Material Certification for Process Wetted and Pressure Retaining Parts
R1	180 Degree Module Rotation ⁽⁹⁾
W1	Additional Customer Tagging Information – Permanent Tag Attached to Electronics Housing (See Figure 2a)
W2	Additional Customer Tagging Information – Wire on Tag Attached to Nameplate (See Figure 2a)
V4	Threaded Vent / Drain Valve(s) (1/4 – 18 NPT) – Unassembled (Provided Separately in Package) ^{(3) (8) (10)}
V5	External Ground Screw Kit
Typical Model Number: 3155ND 2 R 2 F 1 J 2 CP W1	

Note:

- (1) Rosemount 3155N calibration values must be set at the factory during manufacturing. The all-welded design does not allow for major zero elevation or suppression adjustments to the transmitter calibration after manufacturing.
- (2) 3155NG Lower Range Limit (LRL) varies with atmospheric pressure.
- (3) Customer assumes responsibility for qualifying interfaces of these options.
- (4) Field side of connector is available from Rosemount Nuclear Instruments, Inc.; however, customer assumes responsibility for specifying the field side of the connector as a separate item, independent of the 3155N model number.
- (5) When ordered from RNII, the Gen 3 EGS QDC includes the following enhanced design features:
 - 4-pin connector available in 2-wire or 3-wire configurations
 - 16 AWG solid core PEEK-insulated lead wires (Instrument-side)
 - Secondary silicone inner seal (Instrument-side)
 - Shielded Rockbestos Firewall® III cable (FR-XLPE/FR-XLPE), tinned copper braid with laminated copper/polyester tape shield (Field-side)
 - 360° EMI cable shield attachment (Field-side)
- (6) Requires Configuration Data Sheet. Please contact Rosemount Nuclear for details.
- (7) Extended Upper Range Limit (URL) varies by pressure range, please contact Rosemount Nuclear for details. All specifications including a %URL term will be based on the revised URL.
- (8) Quantity is two for DP type transmitters and one for GP type transmitters.
- (9) For rotation option R1, when used with gauge transmitter type, the calibration must be reverse acting (pressure will be applied to low pressure side of the sensor module).
- (10) V4 is not available with process flange code S2. Vent/drain valve(s) option V4 may be selected in the 3159 Remote Seal model number.

Rosemount 3155N

Standard Accessories

One instruction manual is included with each shipment.

Calibration

Transmitters are factory calibrated to the customer's specified range. Rosemount 3155N calibration values must be set at the factory during manufacturing. The all-welded design does not allow for major zero elevation or suppression adjustments to the transmitter calibration after manufacturing. Calibration is performed at ambient temperature and atmospheric pressure.

Additional Customer Tagging Information

Tagging is optional and will be provided when either option W1 or W2 is included in the transmitter model number. All tags are SST. The transmitter will be tagged in accordance with customer requirements (within the space limitations defined below).

	Permanent Tag (W1)	Wire-On Tag (W2)
Nominal Character Height	0.10 in (2.54 mm)	0.188 in (4.76 mm)
Maximum Number of Lines	4	4
Maximum Characters per Line	14	20

Special Options

Please contact Rosemount Nuclear Instruments, Inc. for special transmitter needs.

Spare Parts

A list of 3155N spare parts can be found in Table 6 – 1 of the 3155 Reference Manual 00809-0100-4855.

Documentation

Certifications

Certification will be provided for each Rosemount 3155N pressure transmitter for quality system, nuclear qualification, accuracy, special cleaning, hydrostatic testing, traceability, and special testing if applicable. Chemical and physical reports and identification of pressure-retaining parts will be on file at Rosemount Nuclear Instruments, Inc.

REVISIONS

Changes from October 2015 (Rev AA) to June 2020 (Rev AB)

Page (Old)	Page (New)	Changes
Cover, Throughout	Cover, Throughout	Document revision changed from October 2015 to June 2020, Rev AA to Rev AB
Throughout	Throughout	Changed reference of “QualTech NP EGS QDC Generation 3X” to “EGS QDC Generation 3”
3	3	Figure 2a updated to show consistent number of significant figures
5	5	Revised Steam Pressure/Temperature and Post DBE Operation statement
8, Throughout	8, Throughout	Qualified life statement revised; Removed Figure 6; Updated figure numbering
10	10	Modified title of Figure 6; Changed the lower end of the IEEE Qualified region to accurately reflect how the transmitter was tested.
12	12	Added note clarifying numbers in parenthesis
17	17	Added option S2; Revised footnote (4), (6), and (7); Added footnotes (5), (9), and (10); Updated footnote numbering
Back Cover	Back Cover	Changed contact information phone number

NOTE

The above Revision Status list summarizes the changes made. Please refer to both data sheets for complete comparison details.

NOTE

Revision of the Product Data Sheet has no impact to form, fit, or function and does not impact transmitter qualification. Updates were made to provide clarity and improve customer experience/usage.

Standard Terms and Conditions of Sale can be found at: www.Emerson.com/en-us/pages/Terms-of-Use.aspx

*The Emerson logo is a trademark and service mark of Emerson Electric Co.
Rosemount, the Rosemount logotype are registered trademarks of Rosemount Inc.
Coplanar is a trademark of Rosemount Inc.
Swagelok is a registered trademark of Swagelok Co.
Std 323 and Std 344 are registered trademarks of IEEE
Inconel is a registered trademark of International Nickel Company
All other marks are the property of their respective owners.*

© 2020 Emerson Automation Solutions. All rights reserved.

Global Headquarters
Emerson Automation Solutions
Rosemount Nuclear Instruments, Inc.
8200 Market Boulevard
Chanhassen, MN 55317 USA



Rosemount Nuclear Instruments, Inc. satisfies all obligations coming from legislation to harmonize product requirements in the European Union.

P +1 952 949-5200
F +1 952 949-5201
RNII.info@Emerson.com

