

Rosemount™ 3308 Series Wireless Guided Wave Radar, 3308A



- World's first true wireless Guided Wave Radar based on field proven, market leading technologies
- Accurate, direct level and interface measurements virtually unaffected by process conditions
- Fast and simple commissioning with self-organizing wireless network, intuitive user interface and cut-to-fit probes
- Minimized maintenance with no wires, no moving parts, no re-calibration, long battery life and advanced diagnostics for better process insight

Introduction

Theory of operation

The Rosemount™ 3308 Series is the first true wireless level transmitter that is based on the Time Domain Reflectometry (TDR) principle. Low power nano-second-pulses are guided along a probe submerged in the process media. When a pulse reaches the surface of the material it is measuring, part of the energy is reflected back to the transmitter, and the time difference between the generated and reflected pulse is converted into a distance from which the total level or interface level is calculated (see Figure 1).

Figure 1: Guided Wave Radar Operating Principle

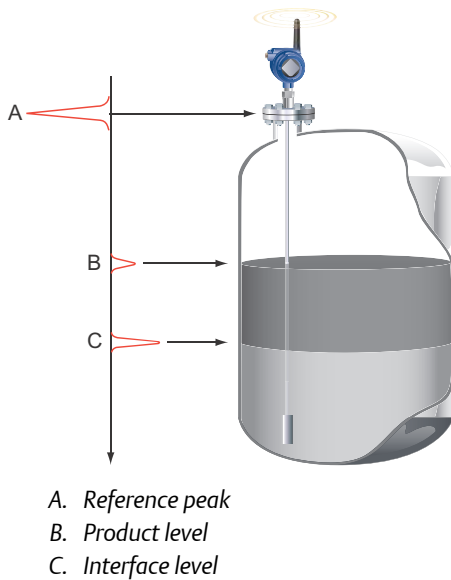

The reflectivity of the product is a key parameter for measurement performance. A high dielectric constant of the media gives better reflection and a longer measuring range.

With innovative technologies inherited from other market leading Rosemount guided wave radars, Rosemount 3308 Series delivers reliable measurements without compromising a long battery life.

Contents

Introduction.....	2
Ordering information.....	6
Specifications.....	21
Installation and mounting considerations.....	36
Product certifications.....	43
Dimensional drawings.....	44
Complementary point level monitoring.....	54

Emerson Wireless

Emerson Wireless is a self-organizing network solution. Wireless field instruments send data to a Gateway, directly or routed through any of the wireless devices in the network, as illustrated in Figure 2. Multiple communication paths are managed and analyzed in parallel to assure optimal communication and sustained network reliability even if obstructions are introduced.

Figure 2: Emerson Wireless Network

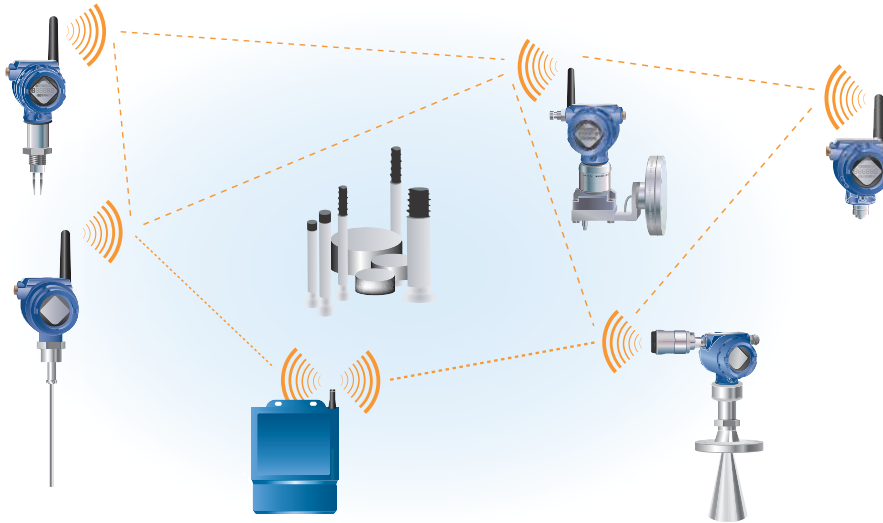

Gateways interface with existing host systems using industry standard protocols, and native integration into DeltaV™ and Ovation™ is transparent and seamless.

Interference from other radios, Wi-Fi®, and EMC sources is avoided through Time Synchronized Channel Hopping and Direct Sequence Spread Spectrum (DSSS). Also, a layered security implementing industry standard Encryption, Authentication, Verification, Anti-Jamming, and Key Management ensures that data transmissions are secure and received only by the Gateway.

The Rosemount 3308A is a member of the Emerson Wireless portfolio, whose wireless network experience totals billions of operating hours, hundreds of thousands of field devices, and tens of thousands of networks around the world.

Access information when you need it with asset tags

Newly shipped devices include a unique QR code asset tag that enables you to access serialized information directly from the device. With this capability, you can:

- Access device drawings, diagrams, technical documentation, and troubleshooting information in your MyEmerson account
- Improve mean time to repair and maintain efficiency
- Ensure confidence that you have located the correct device
- Eliminate the time-consuming process of locating and transcribing nameplates to view asset information

Application examples

The Rosemount 3308 Series Transmitter is suited for aggregate (total) level measurements on a wide range of liquids, semi-liquids, and liquid to liquid interfaces.

Moreover, the reliable and accurate guided wave radar technology offers a versatile solution that is virtually unaffected by process conditions such as temperature, pressure, vapor gas mixtures, density, turbulence, bubbling/boiling, varying dielectric media, pH, and viscosity.

Storage and buffer tanks

The Rosemount 3308 Series Transmitter is ideal for storage or buffer tanks for almost any liquid, such as oil, gas condensate, water, or chemicals.



Low pressure separators

The Rosemount 3308 Series Transmitter can measure both level and interface level, such as for separator applications.



Waste tanks and sump pits

The Rosemount 3308 Series Transmitter is a good choice for waste tanks and underground tanks, such as sump pits.

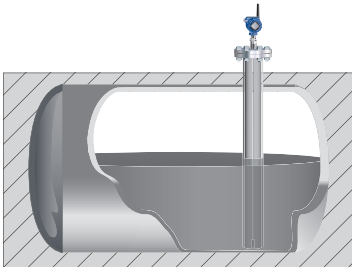

Open applications —ponds, basins, sumps

The Rosemount 3308 Series Transmitter can be installed in open air to measure liquids not contained in a tank.

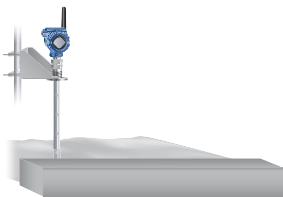

Chamber applications

The Rosemount 3308 Series Transmitter is a good choice for both chamber and pipe installations.

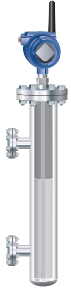

Ordering information

Online product configurator

Many products are configurable online using our Product Configurator. Select the **Configure** button or visit our [website](#) to start. With this tool's built-in logic and continuous validation, you can configure your products more quickly and accurately.

Specifications and options

See the Specifications and options section for more details on each configuration. Specification and selection of product materials, options, or components must be made by the purchaser of the equipment. See the Material selection section for more information.

Model codes

Model codes contain the details related to each product. Exact model codes will vary; an example of a typical model code is shown in [Figure 3](#).

Figure 3: Model Code Example

<u>3308A U X 2 D1 I5 S 1 V 2 AA R 5A E 032 00 WA3 WK1</u>	<u>M5 C1 W1</u>
1	2

1. Required model components (choices available on most)
2. Additional options (variety of features and functions that may be added to products)

Optimizing lead time

The starred offerings (★) represent the most common options and should be selected for the fastest delivery times. The non-starred offerings are subject to additional delivery lead time.

Rosemount 3308 Level Transmitter



Rosemount 3308 Series Guided Wave Radar Level Transmitters are versatile and easy-to-use with field proven, market leading technologies. Characteristics include:

- Intrinsically Safe
- Long battery life
- IEC 62591 (*WirelessHART*[®]) Communication
- Compatible with AMS Device Manager and AMS Wireless Configurator packages for easy commissioning and troubleshooting

[CONFIGURE >](#)
[VIEW PRODUCT >](#)

Required model components

Model

Code	Description	
3308A	Guided Wave Radar Level Transmitter	★

Profile

Code	Description	Reference accuracy	
U ⁽¹⁾	High Performance	±0.12 in. (±3 mm)	★
S	Standard	±0.2 in. (±5 mm)	★

(1) The Rosemount 3308A with Profile code U has two performance modes: Standard and High Performance (default). The performance mode may be reconfigured in field.

Signal output

Code	Description	
X	Wireless	★

Related information

[Wireless](#)

Measurement type

Code	Description	
2	Level and Interface Transmitter	★
1	Level or Interface Transmitter (Interface available for fully submerged probe)	

Housing

Code	Description	
D1	Wireless Dual Compartment Housing, Aluminum (with plugged ½-14 NPT conduits)	★
E1	Wireless Dual Compartment Housing, Stainless steel (with plugged ½-14 NPT conduits)	★

Hazardous locations certifications

Code	Description	
I1	ATEX Intrinsic Safety	★
I2	INMETRO Intrinsic Safety	★
I3	NEPSI Intrinsic Safety	★
I4	CML (Japan) Intrinsic Safety	★
I5	FM Intrinsically Safe	★
I6	Canadian Intrinsically Safe	★
I7	IECEx Intrinsic Safety	★
IM	Technical Regulations Customs Union (EAC) Intrinsic Safety	★
KD	ATEX and Canadian Intrinsic Safety	
KE	FM and Canadian Intrinsically Safe	
KF	ATEX and FM Intrinsic Safety	
NA	No Hazardous Locations Certifications	

Related information[Product Certifications](#)**Operating temperature and pressure**

Process seal rating. Final rating depends on flange and O-ring selection.

Code	Description	
S	Design and operating temperature: -40 to 302 °F (-40 to 150 °C)	Design and operating pressure: -15 to 754 psig (-1 to 52 bar) ⁽¹⁾

(1) Maximum pressure is 580 psig (40 bar) for O-ring material code B (Nitrile Butadiene), Overfill prevention code U1, and Material of construction code 2 or 3.

Related information[Process temperature and pressure rating](#)**Material of construction; process connection/probe**

Code	Description	Probe type	
1	316/316L/EN 1.4404	All	★
2	Alloy C-276 (UNS N10276). With plate design if flanged version.	3A, 3B, 4A, 4B, and 5A	
3	Alloy 400 (UNS N04400). With plate design if flanged version.	3A, 3B, 4A, 4B, and 5A	
7	PTFE covered probe and flange. With plate design.	4A and 5A	
8	PTFE covered probe	4A and 5A	
H	Alloy C-276 (UNS N10276) process connection, flange, and probe	3A, 3B, 4A, 4B, and 5A	
D	Duplex 2205 (EN 1.4462/UNS S31803) process connection, flange, and probe	4B and 5A	

Sealing O-ring material

For other materials, consult the factory.

Code	Description	
V	Fluoroelastomer (FKM)	★
E	Ethylene Propylene (EPDM)	★
K	Kalrez® Perfluoroelastomer (FFKM)	★
B	Nitrile Butadiene (NBR)	★
F	Fluorsilicone (FVMQ)	★

Process connection size

Code	Description	Process connection type	
5	1½-in.	Thread/Tri Clamp	★
2	2-in./DN50/50A	NPT Thread/Flange/Tri Clamp	★
3	3-in./DN80/80A	Flange/Tri Clamp	★
4	4-in./DN100/100A	Flange/Tri Clamp	★
P	Proprietary flanges	Proprietary flange	★
1	1-in.	Thread	
6	6-in./DN150/150A	Flange	
8	8-in./DN200/200A	Flange	

Related information

[Availability of process connections](#)

Process connection rating

Code	Description	
NN	For use with non-flange process connection type	★
ASME rating		
AA	ASME B16.5 Class 150 Flange	★
AB	ASME B16.5 Class 300 Flange	★
EN rating		
DA	EN1092-1 PN16 Flange	★
DB	EN1092-1 PN40 Flange	★
JIS rating		
JA	JIS B2220 10K Flange	★
JB	JIS B2220 20K Flange	★
Proprietary		
PF	Proprietary Flange	★

Related information

[Availability of process connections](#)

Process connection type

Code	Description	
Threads		
N	NPT thread	★
G ⁽¹⁾	BSPP (G) thread	★
Flange faces		
F ⁽¹⁾	Flat Face Type A Flange, available for EN flanges	★
R	Raised Face (RF) Flange, available for ASME and JIS flanges	★
Proprietary flanges		
M	Masoneilan - proprietary 316/316L Torque Tube Flange	★
P	Fisher - proprietary 316/316L (for 249B, 259B chambers) Torque Tube Flange	★
Q	Fisher - proprietary 316/316L (for 249C chambers) Torque Tube Flange	★
Tri Clamp ⁽²⁾		
C	Tri Clamp	

(1) Not available with Canadian Registration Number (CRN).

(2) Follows ISO 2852 standard.

Related information

[Availability of process connections](#)

[Proprietary flanges](#)

Probe type

Code	Description	Process connection type	Probe lengths	
3B	Coaxial, perforated. For level and interface measurement.	Flange/1-, 1½-, 2-in. Thread	Min.: 1 ft. 4 in. (0.4 m) Max.: 19 ft. 8 in. (6 m)	★
4A	Rigid Single Lead (d=0.3"/8 mm)	Flange/1-, 1½-, 2-in. Thread/ Tri Clamp	Min.: 1 ft. 4 in. (0.4 m) ⁽¹⁾ Max.: 9 ft. 10 in. (3 m)	★
4B	Rigid Single Lead (d=0.5"/13 mm)	Flange/1½-, 2-in. Thread/Tri Clamp	Min.: 1 ft. 4 in. (0.4 m) Max.: 19 ft. 8 in. (6 m)	★
5A	Flexible Single Lead (d=0.16"/4mm). Refer to "Options" to specify weight or chuck.	Flange/1-, 1½-, 2-in. Thread/ Tri Clamp	Min.: 3 ft. 4 in. (1 m) ⁽¹⁾ Max.: 55 ft. 9 in. (17 m)	★
2A	Flexible Twin Lead with weight	Flange/1½-, 2-in. Thread	Min.: 3 ft. 4 in. (1 m) Max.: 55 ft. 9 in. (17 m)	
3A ⁽²⁾	Coaxial (for level measurement)	Flange/1-, 1½-, 2-in. Thread	Min.: 1 ft. 4 in. (0.4 m) Max.: 19 ft. 8 in. (6 m)	
4S	Segmented Rigid Single Lead (d=0.5"/13mm)	Flange/1½-, 2-in. Thread	Min.: 1 ft. 4 in. (0.4 m) Max.: 32 ft. 9 in. (10 m)	

(1) Minimum probe length is 4 ft. 11 in. (1.5 m) for PTFE covered probes (Material of construction codes 7 and 8).

(2) Requires model 3308Axx1.

Probe length units

Code	Description	
E	English (feet, inches)	★
M	Metric (meters, centimeters)	★

Related information

[Total probe length](#)

Probe length (feet/meters)

Code	Description	
XXX	0-55 feet or 0-17 meters	★

Probe length (inches/centimeters)

Code	Description	
XX	0-11 inches or 0-99 centimeters	★

Update rate, operating frequency and protocol

Code	Description	
WA3	User Configurable Update Rate, 2.4 GHz, IEC 62591 (<i>WirelessHART</i>)	★

Omnidirectional wireless antenna

Code	Description	
WK	External antenna	★
WM	Extended range, external antenna	★
WN	High-gain, remote antenna (see Figure 30 for dimensions)	★

Related information

[Wireless](#)

SmartPower™ housing cover

I.S. Power Module sold separately.

Code	Description	
1 ⁽¹⁾	Standard life black power module	★
2 ⁽²⁾	Extended life blue power module	★

(1) *Black Power Module must be shipped separately; order Model 701PBKKF. See the Emerson Wireless SmartPower Solutions [Product Data Sheet](#) for more information.*

(2) *Blue Power Module must be shipped separately; order Model MHM-89004. See the Emerson Wireless SmartPower Solutions [Product Data Sheet](#) for more information.*

Additional options

Display

Code	Description	
M5	LCD display	★

Hydrostatic testing

Code	Description	
P1	Hydrostatic testing, including certificate	★

Factory configuration

Code	Description	
C1	Factory configuration per Configuration Data Sheet	★

Special quality assurance

Code	Description	
Q4	Calibration data certificate	★
QG	Calibration certificate and GOST verification certificate (only for end-destination country Russia)	

Material traceability certification

Certificate includes all metallic pressure retaining wetted parts.

Code	Description	
Q8	Material traceability certification per EN 10204 3.1	★

Welding procedure qualification record documentation

Weldings in accordance with EN/ISO standards.

Code	Description	
Q66	Welding Procedure Qualification Record (WPQR)	★
Q67	Welder Performance Qualification (WPQ)	★
Q68	Welding Procedure Specification (WPS)	★

Materials certification

Available for probe type 3A, 3B, 4A, 4B, 4S, and PTFE-coated 5A.

Code	Description	
Q15	NACE® material recommendation per NACE MR0175/ISO 15156	★
Q25	NACE material recommendation per NACE MR0103/ISO 17945	★

Dye penetration test certificate

Code	Description	
Q73	Certificate of liquid penetrant inspection	★

Positive material identification certificate

Code	Description	
Q76	Positive material identification certificate of conformance	★

Installation options

Code	Description	
LS ⁽¹⁾	Long stud 9.8 in (250 mm) for flexible single lead probe to prevent contact with wall/nozzle.	★
BR	Mounting Bracket for 1½-in. NPT Process Connection (see Figure 29)	

(1) Not available with PTFE covered probes.

Weight and anchoring options for flexible single probes

See [Figure 23](#) for dimensions.

Code	Description	
W1	Small Weight (for narrow tank openings less than 2 in. (50 mm)) (Required for PTFE covered probes)	★
W3	Heavy Weight (for most applications)	★
W4	Chuck (to tie probe end to tank bottom)	★
W2	Short Weight (when measuring close to the probe end)	

Weight assembly options for flexible single probes

Code	Description	
WU	Weight or chuck not mounted on the probe	★

Overfill prevention

Code	Description	
U1	Overfill prevention according to WHG/TUV	★

Extended product warranty

Rosemount extended warranties have a limited warranty of three or five years from date of shipment.

Code	Description	
WR3	3-year limited warranty	★
WR5	5-year limited warranty	★

Plantweb™ diagnostic functionality

Code	Description	
DA1	HART® Diagnostics	★

Related information

[HART diagnostics](#)

Centering disc

Available for SST, Alloy C-276, Alloy 400, and Duplex 2205 probes, types 2A, 4A, 4B, 4S, and 5A.

Not available with PTFE covered probes (Material of Construction codes 7 and 8).

Code	Description	
S2 ⁽¹⁾	2-in. Centering disc	★
S3 ⁽¹⁾	3-in. Centering disc	★
S4 ⁽¹⁾	4-in. Centering disc	★
P2	2-in. Centering disc PTFE	★
P3	3-in. Centering disc PTFE	★
P4	4-in. Centering disc PTFE	★
S6 ⁽¹⁾	6-in. Centering disc	
S8 ⁽¹⁾	8-in. Centering disc	
P6	6-in. Centering disc PTFE	
P8	8-in. Centering disc PTFE	

(1) Centering disc in same material as probe material of construction.

Related information

[Centering disc for pipe installations](#)

Assemble/consolidate to chamber

Selecting the XC option code on the Rosemount 3308A and a Rosemount chamber will result in matching, consolidating, configuring, and shipping of the two products in one crate. Note that the flange bolts are only hand-tightened. Long rigid single lead probes (>8 ft./2.5 m) are ship separately in order to reduce transportation risk damage.

Code	Description	
XC	Consolidate to Chamber	★

Related information

[Installation in still pipe/chamber](#)

Specials

Code	Description	
PXXXX	Custom engineered solutions beyond standard model codes. Consult factory for details.	

Related information

[Engineered solutions](#)

Availability of process connections

Table 1: Material of Construction Codes 1, 2, 3, 7, and 8 (Type vs. Size and Rating)

Process connection size	Process connection rating							Proprietary flanges ⁽¹⁾
	Thread/Tri Clamp	ASME B16.5 flanges		EN1092-1 flanges		JIS B2220 flanges		
		Class 150	Class 300	PN16	PN40	10K	20K	
1-in.	G ⁽²⁾ , N ⁽²⁾	N/A	N/A	N/A	N/A	N/A	N/A	N/A
1½-in.	C ⁽²⁾ , N ⁽³⁾ , G ⁽³⁾	N/A	N/A	N/A	N/A	N/A	N/A	N/A
2-in./DN50/50A	C ⁽²⁾ , N ⁽²⁾	R	R	F	F	R	R	N/A
3-in./DN80/80A	C ⁽²⁾	R	R	F	F	R	R	N/A
4-in./DN100/100A	C ⁽²⁾	R	R	F	F	R	R	N/A
6-in./DN150/150A	N/A	R	R	F	F	R	R	N/A
8-in./DN200/200A	N/A	R	R	F	F	R	R	N/A
Proprietary flanges	N/A	N/A	N/A	N/A	N/A	N/A	N/A	M, P, Q

(1) Only available with material of construction codes 1, 7, and 8.

(2) Only available with material of construction codes 1 and 8.

(3) Only available with material of construction codes 1, 2, 3, and 8.

C = Tri Clamp (process connection type code C)

F = Flat Face Type A (process connection type code F)

G = BSPP (G) thread (process connection type code G)

M = Masoneilan™ (process connection type code M)

N = NPT thread (process connection type code N)

P = Fisher™ 249B/259B (process connection type code P)

Q = Fisher 249C (process connection type code Q)

R = Raised Face (process connection type code R)

Table 2: Material of Construction Codes H and D (Type vs. Size and Rating)

Process connection size	Process connection rating							Proprietary flanges
	Thread/ Tri Clamp	ASME B16.5 flanges		EN1092-1 flanges		JIS B2220 flanges		
		Class 150	Class 300	PN16	PN40	10K	20K	
1-in.	N/A	N/A	N/A	N/A	N/A	N/A	N/A	N/A
1½-in.	G, N	N/A	N/A	N/A	N/A	N/A	N/A	N/A
2-in./DN50/50A	N/A	R	R	N/A	N/A	N/A	N/A	N/A
3-in./DN80/80A	N/A	R	R	N/A	N/A	N/A	N/A	N/A
4-in./DN100/100A	N/A	R	R	N/A	N/A	N/A	N/A	N/A
6-in./DN150/150A	N/A	R ⁽¹⁾	N/A	N/A	N/A	N/A	N/A	N/A
8-in./DN200/200A	N/A	N/A	N/A	N/A	N/A	N/A	N/A	N/A
Proprietary flanges	N/A	N/A	N/A	N/A	N/A	N/A	N/A	N/A

(1) Only available with material of construction code H.

G = BSPP (G) thread (process connection type code G)

N = NPT thread (process connection type code N)

R = Raised Face (process connection type code R)

Accessories

Centering discs for rigid single lead probe (d=0.3 in./8 mm)

If a centering disc is required for a flanged probe, the centering disc can be ordered with options Sx or Px in the model code. If a centering disc is required for a threaded connection, or as a spare part, it should be ordered using the item numbers listed in this table.

For other materials, consult the factory.

Item number	Description	Outer diameter	
03300-1655-0001	Kit, 2-in. Centering disc, SST	1.8 in. (45 mm)	★
03300-1655-0006	Kit, 2-in. Centering disc, PTFE	1.8 in. (45 mm)	★
03300-1655-0002	Kit, 3-in. Centering disc, SST	2.7 in. (68 mm)	★
03300-1655-0007	Kit, 3-in. Centering disc, PTFE	2.7 in. (68 mm)	★
03300-1655-0003	Kit, 4-in. Centering disc, SST	3.6 in. (92 mm)	★
03300-1655-0008	Kit, 4-in. Centering disc, PTFE	3.6 in. (92 mm)	★
03300-1655-0004	Kit, 6-in. Centering disc, SST	5.55 in. (141 mm)	
03300-1655-0009	Kit, 6-in. Centering disc, PTFE	5.55 in. (141 mm)	
03300-1655-0005	Kit, 8-in. Centering disc, SST	7.40 in. (188 mm)	
03300-1655-0010	Kit, 8-in. Centering disc, PTFE	7.40 in. (188 mm)	

Related information

[Centering disc for pipe installations](#)

Centering discs for rigid single lead probe (d=0.5 in./13 mm)

If a centering disc is required for a flanged probe, the centering disc can be ordered with options Sx or Px in the model code. If a centering disc is required for a threaded connection, or as a spare part, it should be ordered using the item numbers listed in this table.

For other materials, consult the factory.

Item number	Description	Outer diameter	
03300-1655-0301	Kit, 2-in. Centering disc, SST	1.8 in. (45 mm)	★
03300-1655-0306	Kit, 2-in. Centering disc, PTFE	1.8 in. (45 mm)	★
03300-1655-0302	Kit, 3-in. Centering disc, SST	2.7 in. (68 mm)	★
03300-1655-0307	Kit, 3-in. Centering disc, PTFE	2.7 in. (68 mm)	★
03300-1655-0303	Kit, 4-in. Centering disc, SST	3.6 in. (92 mm)	★
03300-1655-0308	Kit, 4-in. Centering disc, PTFE	3.6 in. (92 mm)	★
03300-1655-0304	Kit, 6-in. Centering disc, SST	5.55 in. (141 mm)	
03300-1655-0309	Kit, 6-in. Centering disc, PTFE	5.55 in. (141 mm)	
03300-1655-0305	Kit, 8-in. Centering disc, SST	7.40 in. (188 mm)	
03300-1655-0310	Kit, 8-in. Centering disc, PTFE	7.40 in. (188 mm)	

Related information[Centering disc for pipe installations](#)**Snap-on centering discs for flexible single lead probes**

Maximum temperature for the snap-on centering discs is 392 °F (200 °C).

Item number	Description	
03300-1658-0001	Kit, 2- to 4-in. snap-on centering disc, PEEK, 1 pc	
03300-1658-0002	Kit, 2- to 4-in. snap-on centering disc, PEEK, 3 pcs	
03300-1658-0003	Kit, 2- to 4-in. snap-on centering disc, PEEK, 5 pcs	

Centering discs for flexible single/twin lead probes

If a centering disc is required for a flanged probe, the centering disc can be ordered with options Sx or Px in the model code. If a centering disc is required for a threaded connection, or as a spare part, it should be ordered using the item numbers listed in this table.

For other materials, consult the factory.

Item number	Description	Outer diameter	
03300-1655-1001	Kit, 2-in. Centering disc, SST	1.8 in. (45 mm)	★
03300-1655-1006	Kit, 2-in. Centering disc, PTFE	1.8 in. (45 mm)	★
03300-1655-1002	Kit, 3-in. Centering disc, SST	2.7 in. (68 mm)	★
03300-1655-1007	Kit, 3-in. Centering disc, PTFE	2.7 in. (68 mm)	★
03300-1655-1003	Kit, 4-in. Centering disc, SST	3.6 in. (92 mm)	★
03300-1655-1008	Kit, 4-in. Centering disc, PTFE	3.6 in. (92 mm)	★
03300-1655-1004	Kit, 6-in. Centering disc, SST	5.55 in. (141 mm)	
03300-1655-1009	Kit, 6-in. Centering disc, PTFE	5.55 in. (141 mm)	
03300-1655-1005	Kit, 8-in. Centering disc, SST,	7.40 in. (188 mm)	
03300-1655-1010	Kit, 8-in. Centering disc, PTFE	7.40 in. (188 mm)	

Related information[Centering disc for pipe installations](#)**Centering discs for mounting between segments (probe type 4S only)**

Item number	Description	Outer diameter	
03300-1656-1002	2-in. Centering disc (1 pc), PTFE, Segmented rigid single lead	1.8 in. (45 mm)	
03300-1656-1003	3-in. Centering disc (1 pc), PTFE, Segmented rigid single lead	2.7 in. (68 mm)	
03300-1656-1004	4-in. Centering disc (1 pc), PTFE, Segmented rigid single lead	3.6 in. (92 mm)	
03300-1656-1006	6-in. Centering disc (1 pc), PTFE, Segmented rigid single lead	5.55 in. (141 mm)	
03300-1656-1008	8-in. Centering disc (1 pc), PTFE, Segmented rigid single lead	7.40 in. (188 mm)	
03300-1656-3002	2-in. Centering disc (3 pcs), PTFE, Segmented rigid single lead	1.8 in. (45 mm)	
03300-1656-3003	3-in. Centering disc (3 pcs), PTFE, Segmented rigid single lead	2.7 in. (68 mm)	

Item number	Description	Outer diameter
03300-1656-3004	4-in. Centering disc (3 pcs), PTFE, Segmented rigid single lead	3.6 in. (92 mm)
03300-1656-3006	6-in. Centering disc (3 pcs), PTFE, Segmented rigid single lead	5.55 in. (141 mm)
03300-1656-3008	8-in. Centering disc (3 pcs), PTFE, Segmented rigid single lead	7.40 in. (188 mm)
03300-1656-5002	2-in. Centering disc (5 pcs), PTFE, Segmented rigid single lead	1.8 in. (45 mm)
03300-1656-5003	3-in. Centering disc (5 pcs), PTFE, Segmented rigid single lead	2.7 in. (68 mm)
03300-1656-5004	4-in. Centering disc (5 pcs), PTFE, Segmented rigid single lead	3.6 in. (92 mm)
03300-1656-5006	6-in. Centering disc (5 pcs), PTFE, Segmented rigid single lead	5.55 in. (141 mm)
03300-1656-5008	8-in. Centering disc (5 pcs), PTFE, Segmented rigid single lead	7.40 in. (188 mm)

Segmented rigid single lead probe spare part kit

Item number	Description
03300-0050-0001	15.2 in. / 385 mm Segment for Top connection (1 pc)
03300-0050-0002	31.5 in. / 800 mm Segment (1 pc)
03300-0050-0003	31.5 in. / 800 mm Segment (3 pcs)
03300-0050-0004	31.5 in. / 800 mm Segment (5 pcs)
03300-0050-0005	31.5 in. / 800 mm Segment (12 pcs)

Vented flanges

1½-in. NPT threaded connection is required.

Not available with Canadian Registration Number (CRN).

Item number	Description
03300-1812-0092	Fisher™ (249B, 259B), one ¼-in. NPT connection, 316/316L
03300-1812-0093	Fisher (249C), one ¼-in. NPT connection, 316/316L
03300-1812-0091	Masoneilan™, one ¼-in. NPT connection, 316/316L

Flushing connection rings

Not available with Canadian Registration Number (CRN).

Item number	Description
DP0002-2111-S6	2-in. ANSI, one ¼-in. NPT connection, 316L
DP0002-3111-S6	3-in. ANSI, one ¼-in. NPT connection, 316L
DP0002-4111-S6	4-in. ANSI/DN100, one ¼-in. NPT connection, 316L
DP0002-5111-S6	DN50, one ¼-in. NPT connection, 316L
DP0002-8111-S6	DN80, one ¼-in. NPT connection, 316L

HART modem and cables

Item number	Description	
03300-7004-0001	MACTek® VIATOR® HART Modem and cables (RS232 connection)	★
03300-7004-0002	MACTek VIATOR HART Modem and cables (USB connection)	★

Specifications

Performance specifications

General

Reference conditions

- Probe: Flexible single lead
- Vessel: 4-in. pipe
- Measurement target: Water
- Temperature: 68 to 77 °F (20 to 25 °C)
- Relative humidity: 30-80%

Reference accuracy

High performance (profile code U):	±0.12 in. (±3 mm), when distance < 33 ft. (10 m) ±0.03% of measured distance, when distance > 33 ft. (10 m)
Standard (profile code S):	±0.2 in. (±5 mm), when distance < 33 ft. (10 m) ±0.05% of measured distance, when distance > 33 ft. (10 m)

Refer to the IEC 60770-1 standard for a definition of radar specific performance parameters and if applicable corresponding test procedure.

Ambient temperature effect

±0.08 in. (±2 mm)/10 K⁽¹⁾

Electromagnetic interference effect

Deviation through electromagnetic interference according to EN 61326:

- External antenna (WK option): < ±0.25 in. (±6 mm)
- Extended range, external antenna (WM option): < ±0.35 in. (±9 mm)
- Remote (WN option): < ±0.2 in. (±5 mm)

Power module battery life

- High performance: 5 years at one minute update rate
- Standard: 9 years at one minute update rate

Reference conditions are 70 °F (21 °C), and routing data for three additional network devices.

Environment

Vibration resistance

No effect when tested per the requirements of IEC60770-1 (1999): High Vibration Level - field or pipeline (10-60 Hz 0.21 mm displacement peak amplitude / 60-2000 Hz 3g).⁽²⁾

(1) Ambient temperature effect specification valid over temperature range -40 °F to 185 °F (-40 °C to 85 °C).

(2) Currently only valid for models supplied with Adapter for Black Power Module.

Electromagnetic compatibility

- Meets EN 61326-1:2013, EN 61326-2-3:2013, and NE21:2012 if installed in metallic vessels or still pipes.
- For optimal single lead probe performance in non-metallic tanks, the probe must be mounted with a metal flange, or screwed in to a metal sheet (d > 14 in./350 mm) if a threaded version is used.

Related information

[Installation in non-metallic tanks and open-air applications](#)

Pressure Equipment Directive (PED)

Complies with 2014/68/EU article 4.3

Radio approvals

- Radio Equipment Directive (RED) 2014/53/EU
- Part 15 of the FCC Rules
- Industry Canada RSS 211

Contamination/product build-up

- Single lead probes are preferred when there is a risk of contamination (because build-up can result in the product bridging across the two leads for twin versions; between the inner lead and outer pipe for the coaxial probe).
- For viscous or sticky applications, PTFE probes are recommended. Periodic cleaning may also be required.
- For viscous or sticky applications, it is not recommended to use centering discs mounted along the single lead probe.
- Signal Quality Metrics (option code DA1) can be used to determine when to clean the probe. Transmitters equipped with the Diagnostics Suite option can calculate Signal Quality Metrics.

Table 3: Maximum Recommended Viscosity and Contamination/Build-up

Probe type	Maximum viscosity	Contamination/build-up
Single lead	8000 cP ⁽¹⁾	Build-up allowed
Twin lead	1500 cP	Thin build-up allowed, but no bridging
Coaxial	500 cP	Not recommended

(1) Consult your local Emerson representative in the case of agitation/turbulence and high viscous products.

Measuring range

Table 4: Measuring Range and Minimum Dielectric Constant

Probe type	Maximum measuring range	Minimum dielectric constant ⁽¹⁾
Flexible single lead	55.8 ft. (17 m)	2.0, when distance < 32.8 ft. (10 m)
		10, when distance > 32.8 ft. (10 m)
Rigid single lead probe (0.3-in./8 mm)	9.8 ft. (3 m)	2.0
Rigid single lead probe (0.5-in./13 mm)	19.7 ft. (6 m)	2.0
Segmented rigid single lead	32.8 ft. (10 m)	2.0
Flexible twin lead	55.8 ft. (17 m)	2.0, when distance < 32.8 ft. (10 m)
		10, when distance > 32.8 ft. (10 m)

Table 4: Measuring Range and Minimum Dielectric Constant (continued)

Probe type	Maximum measuring range	Minimum dielectric constant ⁽¹⁾
Coaxial	19.7 ft. (6 m)	2.0

(1) Minimum Dielectric Constant may be lower than 2.0 if one or more of the following conditions apply:

- Probe is installed in stilling well or chamber.
- Maximum measuring range is not utilized.
- Noise Threshold is manually adjusted to a lower level.

Interface measuring range

The maximum allowable upper product thickness/measuring range is primarily determined by the dielectric constants of the two liquids.

Typical applications include interfaces between oil/oil-like and water/water-like liquids, with a low (<3) dielectric constant for the upper product and a high (>20) dielectric constant for the lower product. For such applications, the maximum measuring range is limited by the length of the coaxial and rigid single lead probes.

For flexible probes, the maximum measuring range is reduced by the maximum upper product thickness, according to the diagram below. However, characteristics may vary between the different applications.

Figure 4: Interface Level Measurement

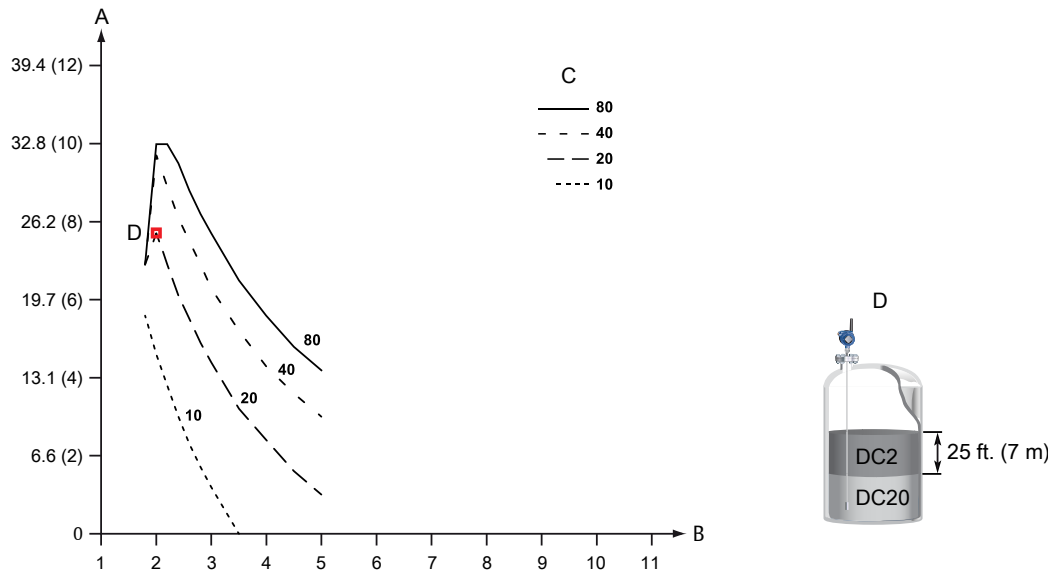

- A. Maximum upper product thickness, ft. (m)
- B. Upper product dielectric constant
- C. Lower product dielectric constant
- D. For example, with an upper product dielectric constant of 2, and a lower product dielectric constant of 20, the maximum upper product thickness is 25 ft. (7 m).

Accuracy over measuring range

The measuring range depends on probe type, dielectric constant of the product and installation environment, and is limited by the Blind Zones at the very top and bottom of the probe. In the Blind Zones, the accuracy exceeds ±1.18 in. (30 mm), and measurements may not be possible. Measurements close to the Blind Zones will have reduced accuracy.

The following conditions will impact the Blind Zones:

- If the single lead probes or twin probes are installed in a nozzle, the nozzle height shall be added to the specified Upper Blind Zone.

- The measuring range for the PTFE covered flexible single lead probe includes the weight when measuring on a high dielectric media.

Figure 5: Blind Zones

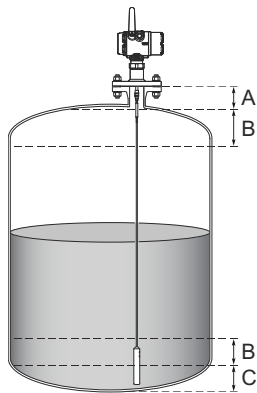

- A. Upper Blind Zone
- B. Reduced accuracy
- C. Lower Blind Zone

Note

Measurements may not be possible in the Blind Zones, and measurements close to the Blind Zones will have reduced accuracy. Therefore, the alarm points should be configured outside these zones.

Figure 6, Figure 7, Figure 8, and Figure 9 illustrate the accuracy over measuring range at reference condition using the Trim Near Zone function, with alternating probe types and varying dielectric constant of the product.

Figure 6: Accuracy over Measuring Range for Flexible Single Lead Probe

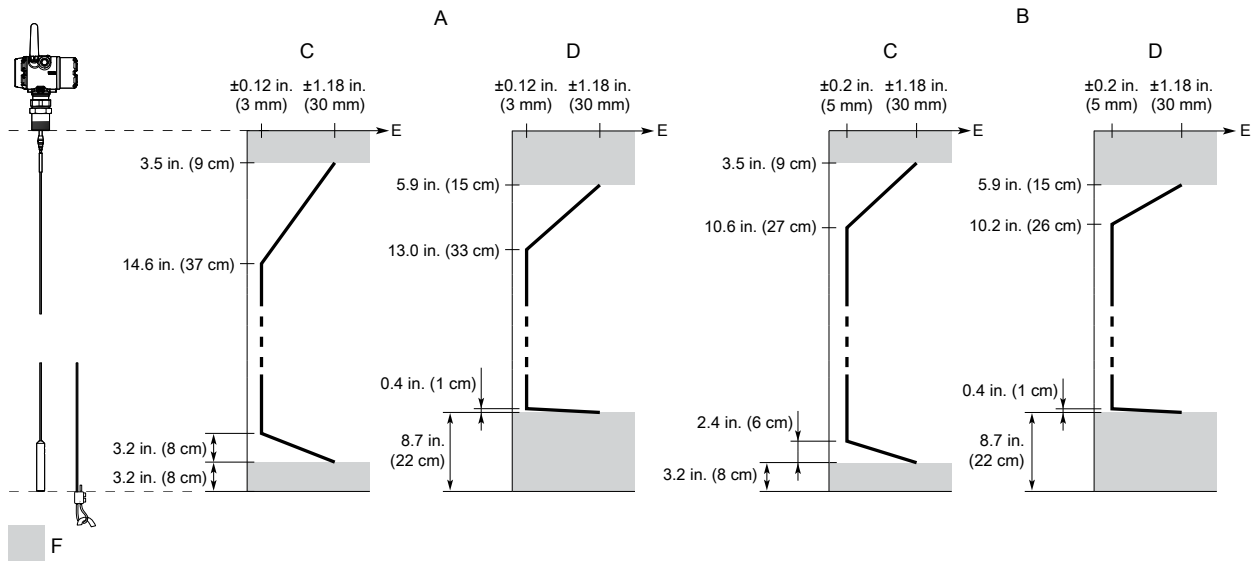

- A. High performance (profile code U)
- B. Standard (profile code S)
- C. Water (DC = 80)
- D. Oil (DC = 2.2)
- E. Accuracy
- F. Blind Zone

Figure 7: Accuracy over Measuring Range for Rigid Single Lead/Segmented Rigid Single Probes

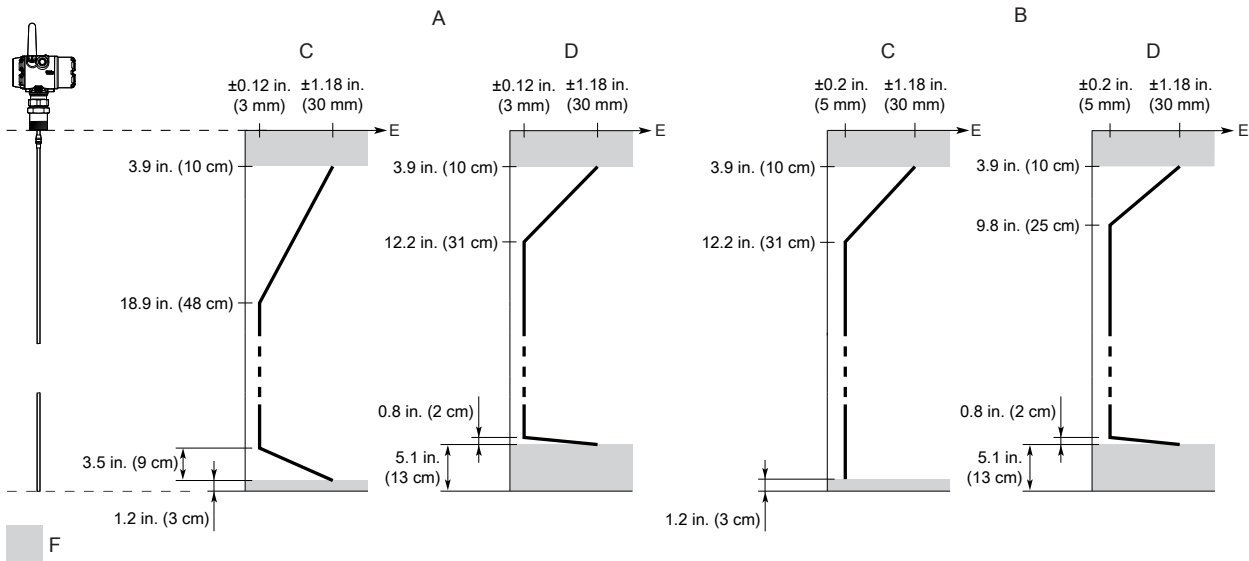

- A. High performance (profile code U)
- B. Standard (profile code S)
- C. Water (DC = 80)
- D. Oil (DC = 2.2)
- E. Accuracy
- F. Blind Zone

Figure 8: Accuracy over Measuring Range for Flexible Twin Lead Probe

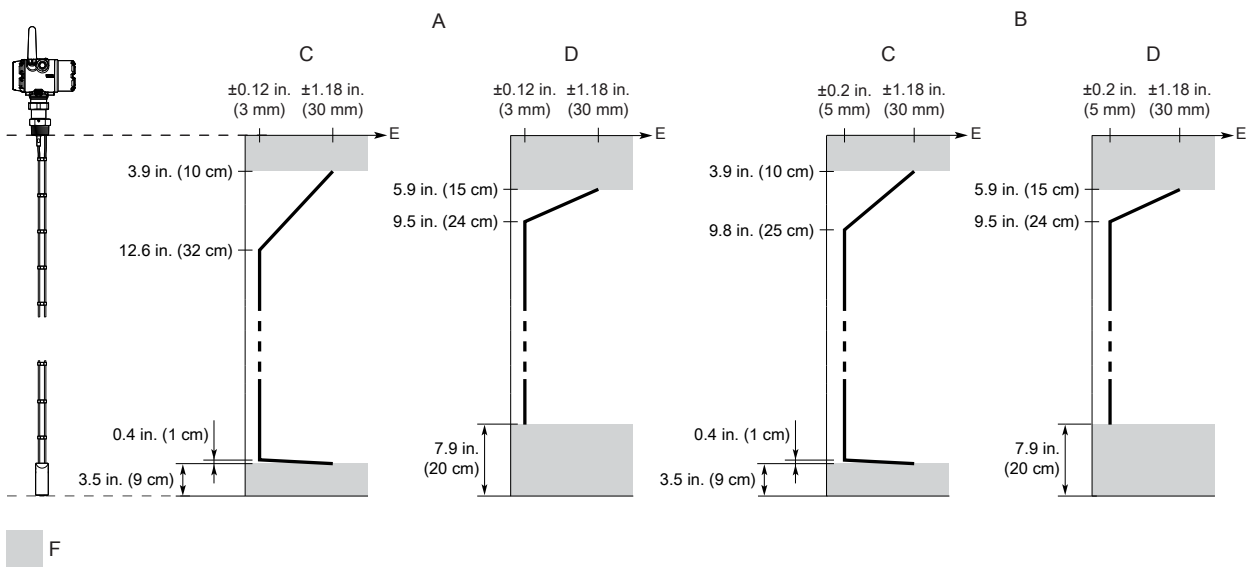

- A. High performance (profile code U)
- B. Standard (profile code S)
- C. Water (DC = 80)
- D. Oil (DC = 2.2)
- E. Accuracy
- F. Blind Zone

Figure 9: Accuracy over Measuring Range for Coaxial Probe

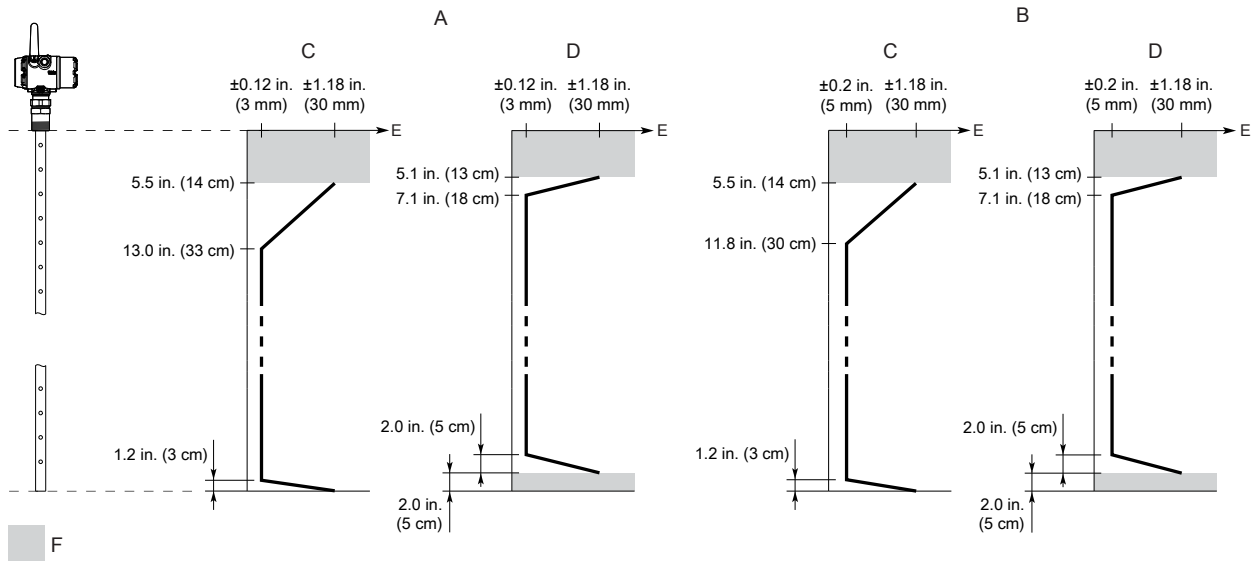

- A. High performance (profile code U)
- B. Standard (profile code S)
- C. Water (DC = 80)
- D. Oil (DC = 2.2)
- E. Accuracy
- F. Blind Zone

Functional specifications

General

Field of application

Liquids and semi-liquids level or liquid/liquid interfaces

- 3308Axx1... for level or submerged probe interface measurement
- 3308Axx2... for level and interface measurement

Measurement principle

Time Domain Reflectometry (TDR)

Related information

[Theory of operation](#)

Microwave output power

Nominal 10 μ W, Max <20 mW

Humidity

0 to 100% relative humidity

Wireless

Output

IEC 62591 (WirelessHART®) 2.4 GHz

Transmit rate

User selectable, 4 seconds to 60 minutes

Frequency range

2400 - 2483.5 MHz

Radio frequency output from antenna

- External antenna (WK option): < 10 mW (+10dBm) EIRP
- Extended range, external antenna (WM option): < 18 mW (12.5dBm) EIRP
- Remote (WN option): < 40mW (16dBm) EIRP

Modulation type

QPSK/iIEEE 802.15.4 IEC 62591 (WirelessHART)

Number of channels

15

Channel spacing

5 MHz

Emission designation

G1D

Display and configuration

LCD display

- Toggles between selected output variables
- Shows diagnostic information (alerts)
- Display updates at each wireless update

Figure 10: Device Display

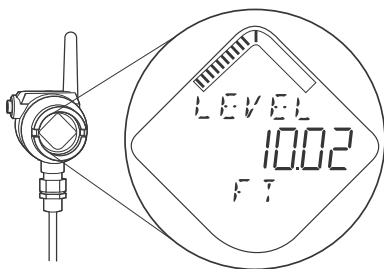

Output units

- Level, Interface, and Distance: ft, inch, m, cm, or mm
- Volume: ft³, inch³, US gals, Imp gals, barrels, yd³, m³, or liters
- Temperature: °F, °C

Output variables

Table 5: Output Variables

Variable	LCD display	PV, SV, TV, QV
Level	✓	✓
Distance	✓	✓
Surface Signal Strength	N/A	✓
Total Volume	✓	✓
Interface Level ⁽¹⁾	✓	✓
Interface Distance ⁽¹⁾	✓	✓
Interface Signal Strength ⁽¹⁾	N/A	✓ ⁽²⁾
Upper Product Thickness ⁽³⁾	✓	✓
Electronics Temperature	✓	✓ ⁽²⁾
Signal Quality	✓	✓ ⁽²⁾
Supply Voltage	✓	✓ ⁽²⁾
% of Range	✓	✓ ⁽²⁾

(1) For 3308Axx1, Interface measurement is only available for fully submerged probe.

(2) Not available as primary variable.

(3) Only available with 3308Axx2.

HART diagnostics

Signal Quality Metrics - Diagnostics package that monitors the relations between surface, noise and threshold. The function can be used to detect abnormal conditions in the process such as probe contamination or sudden loss of signal strength. Signal Quality is available as Output Variable and it comes with user configurable alerts through AMS Wireless Configurator or the handheld communicator.

Temperature limits

Verify that the operating atmosphere of the transmitter is consistent with the appropriate hazardous locations certifications, see [Product Certifications](#).

Table 6: Ambient Temperature Limits

Description	Operating limit	Storage limit
With LCD Display	-40 to 175 °F (-40 to 80 °C) ⁽¹⁾	-40 to 185 °F (-40 to 85 °C)
Without LCD Display	-40 to 185 °F (-40 to 85 °C)	-40 to 185 °F (-40 to 85 °C)

(1) LCD display may not be readable and device display updates will be slower at temperatures below -4 °F (-20 °C).

Process temperature and pressure rating

Figure 11 gives the maximum process temperature (measured at the lower part of the flange or threaded connection) and pressure rating.

Final rating depends on flange, material of construction, and O-ring selection.

Figure 11: Maximum Rating, Standard Tank Connections

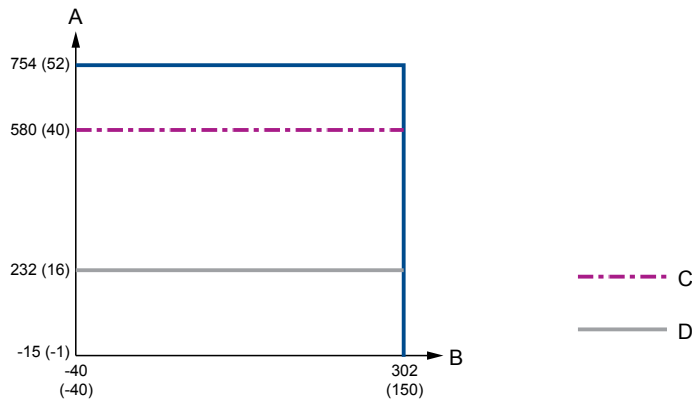

- A. Pressure psig (bar)
- B. Temperature °F (°C)
- C. O-ring material code B (Nitrile Butadiene)
Overfill prevention code U1 (Overfill prevention according to WHG/TUV)
Protective plate: Alloy C-276 (Material of construction code 2) or Alloy 400 (Material of construction code 3)
- D. Protective plate: PTFE (Material of construction code 7)

Table 7: Temperature and Pressure Ranges for Standard Tank Seals with Different O-ring Material

O-ring material	Temperature °F (°C) in air		Pressure psig (bar)
	Minimum	Maximum	Maximum
Fluoroelastomer (FKM)	-22 (-30)	302 (150)	754 (52)
Ethylene Propylene (EPDM)	-40 (-40)	266 (130)	754 (52)
Kalrez® Perfluoroelastomer (FFKM)	14 (-10)	302 (150)	754 (52)
Nitrile Butadiene (NBR)	-31 (-35)	230 (110)	580 (40)
Fluorosilicone (FVMQ)	-49 (-45)	302 (150)	754 (52)

Note

Always check the chemical compatibility of the O-ring material with your application. If the O-ring material is not compatible with its chemical environment, the O-ring may eventually malfunction.

Flange rating

ASME flange rating

316 according to ASME B16.5 Table 2-2.2:

- Maximum 302 °F/754 psig (150 °C/52 bar)

Alloy C-276 (UNS N10276) according to ASME B16.5 Table 2-3.8:

- Maximum 302 °F/754 psig (150 °C/52 Bar)

Duplex 2205 (UNS S31803) according to ASME B16.5 Table 2-2.8:

- Maximum 302 °F/754 psig (150 °C/52 Bar)

EN flange rating

EN 1.4404 according to EN 1092-1 material group 13E0:

- Maximum 302 °F/754 psig (150 °C/52 Bar)

Alloy C-276 (UNS N10276) according to EN 1092-1 material group 12E0:

- Maximum 302 °F/754 psig (150 °C/52 Bar)

Duplex 2205 (EN 1.4462) according to EN 1092-1 material group 16E0:

- Maximum 754 psig (52 Bar), -22 °F (-30 °C) up to maximum 302 °F (150 °C)⁽³⁾

JIS flange rating

316 according to JIS B2220 material group 2.2:

- Maximum 302 °F/754 psig (150 °C/52 Bar)

Fisher and Masoneilan flange rating

316 according to ASME B16.5 Table 2-2.2:

- Maximum 302 °F/754 psig (150 °C/52 Bar)

Tri Clamp rating

Table 8: Tri Clamp Rating

Size	Maximum pressure ⁽¹⁾
1½-in. (37.5 mm)	232 psig (16 bar)
2-in. (50 mm)	232 psig (16 bar)
3-in. (75 mm)	145 psig (10 bar)
4-in. (100 mm)	145 psig (10 bar)

(1) The final rating depends on the clamp and gasket.

(3) Minimum and maximum temperature limit due to EN13445-2.

Plate design

Certain models of flanged alloy and PTFE covered probes have a tank connection design with a protective flange plate that prevents the backing flange from being exposed to the tank atmosphere. The protective flange plate is manufactured in the same material as the probe. The backing flange is made of 316L/EN 1.4404 for alloy probes, and 316/1.4404 for PTFE covered probes.

Figure 12: Protective Plate

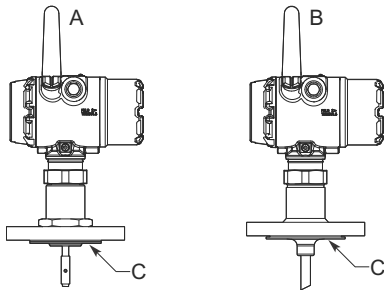

- A. Alloy probe and protective plate
- B. PTFE covered probe and protective plate
- C. Protective plate

PTFE protective plate

Flange rating according to SST backing flange ASME B16.5 Table 2-2.2, EN 1092-1 material group 13E0, and JIS B2220 material group 2.3.

- Maximum 302 °F/232 psig (150 °C/16 Bar)

Alloy C-276 protective plate

Flange rating according to SST backing flange ASME B16.5 Table 2-2.3, EN 1092-1 material group 13E0, and JIS B2220 material group 2.3.

- Maximum 302 °F/580 psig (150 °C/40 Bar)

Alloy 400 protective plate

Flange rating according to SST backing flange ASME B16.5 Table 2-2.3, EN 1092-1 material group 13E0, and JIS B2220 material group 2.3.

- Maximum 302 °F/580 psig (150 °C/40 Bar)

Interface measurements

The Rosemount 3308 Series is well suited for interface measurements, including applications where the probe is fully submerged in the liquid.

Figure 13: Interface Level Measurement

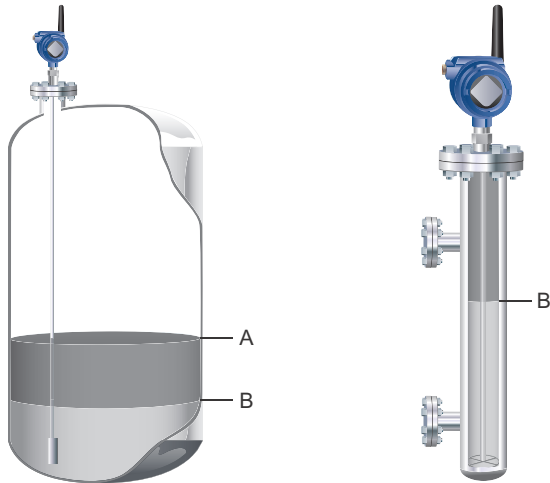

- A. Product level
- B. Interface level

Interface measurement considerations

If interface is to be measured, follow these criteria:

- The dielectric constant of the upper product should be known and should not vary. The AMS Wireless Configurator and handheld communicator have a built-in Dielectric Constant Guide to assist users in determining the dielectric constant of the upper product.
- The dielectric constant of the upper product must have a lower dielectric constant than the lower product to have a distinct reflection.
- The difference between the dielectric constants for the two products must be larger than 10.
- Maximum dielectric constant for the upper product is 10 for the coaxial probe, and 5 for the single lead and flexible twin lead probes.
- Minimum detectable upper product thickness is 4 in. (10 cm) when the upper product is oil (DC=2.2) and the lower product is water (DC=80).

Related information

[Interface measuring range](#)

Emulsion layers

Sometimes there is an emulsion layer (mix of the products) between the two products which can affect interface measurements. For guidelines on emulsion situations, consult your local Emerson representative.

Conditions used for flange strength calculations

Table 9: 316/316L Flanges

Standard	Bolting material	Gasket	Flange material	Hub material
ASME	Stainless steel SA193 B8M Cl.2	Soft (1a) with min. thickness 1.6 mm	Stainless steel A182 Gr. F316 and EN 10222-5-1.4404	Stainless steel SA479M 316, and EN 10272-1.4404
EN, JIS	EN 1515-1/-2 group 13E0, A4-70	Soft (EN 1514-1) with min. thickness 1.6 mm		

Table 10: Process Connection with Plate Design

Standard	Bolting material	Gasket	Flange material	Hub material
ASME	Stainless steel SA193 B8M Cl.2	Soft (1a) with min. thickness 1.6 mm	Stainless steel A182 Gr. F316L/F316 and EN 10222-5-1.4404	SB574 Gr. N10276 or SB164 Gr. N04400
EN, JIS	EN 1515-1/-2 group 13E0, A4-70	Soft (EN 1514-1) with min. thickness 1.6 mm		

Table 11: Alloy C-276 Flanges

Standard	Bolting material	Gasket	Flange material	Hub material
ASME	UNS N10276	Soft (1a) with min. thickness 1.6 mm	SB462 Gr. N10276 (solution annealed condition) or SB575 Gr. N10276 (solution annealed condition)	SB574 Gr. N10276
EN, JIS		Soft (EN 1514-1) with min. thickness 1.6 mm		

Table 12: Duplex 2205 Flanges

Standard	Bolting material	Gasket	Flange material	Hub material
ASME	A193 B7 or A320 L7	Soft (1a) with min. thickness 1.6 mm	Duplex stainless steel SA/A182 F51 and EN10222-5-1.4462 or SA/A240 Gr. S31803 and EN10028-7-1.4462	Stainless steel SA479M S31803 and EN 10272-1.4462
EN, JIS	Bumax® 88	Soft (EN 1514-1) with min. thickness 1.6 mm		

Physical specifications

Material selection

Emerson provides a variety of Rosemount products with various product options and configurations, including materials of construction that can be expected to perform well in a wide range of applications. The Rosemount product information presented is intended as a guide for the purchaser to make an appropriate selection for the application. It is the purchaser's sole responsibility to make a careful analysis of all process parameters (such as all chemical components, temperature, pressure, flow rate, abrasives, contaminants, etc.), when specifying product, materials, options, and components for the particular application. Emerson is not in a position to evaluate or guarantee the compatibility of the process fluid or other process parameters with the product, options, configuration, or materials of construction selected.

Engineered solutions

When standard model codes are not sufficient to fulfill requirements, please consult the factory to explore possible Engineered Solutions. This is typically, but not exclusively, related to the choice of wetted materials or the design of a process connection. These Engineered Solutions are part of the expanded offerings and may be subject to additional delivery lead time. For ordering, factory will supply a special P-labeled numeric option code that should be added at the end of the standard model string.

Housing and enclosure

Ingress protection

IP66/67 and NEMA® 4X

Tank connection

The tank connection consists of a tank seal, a flange, Tri Clamp, or NPT or BSPP (G) threads.

Flange dimensions

Follows ASME B16.5, JIS B2220, and EN 1092-1 standards for blind flanges. For Proprietary Fisher™ and Masoneilan™ flanges, see [Proprietary flanges](#).

Tri Clamp connection

Follows ISO 2852 standard.

Probes

Probe versions

Flexible single lead, rigid single lead, segmented rigid single lead, flexible twin lead, and coaxial.

For guidelines on which probe to select depending on application, see the Rosemount 3308A [Reference Manual](#).

Total probe length

This is defined from the Upper Reference Point to the end of the probe (weight included, if applicable).

Figure 14: Total Probe Length

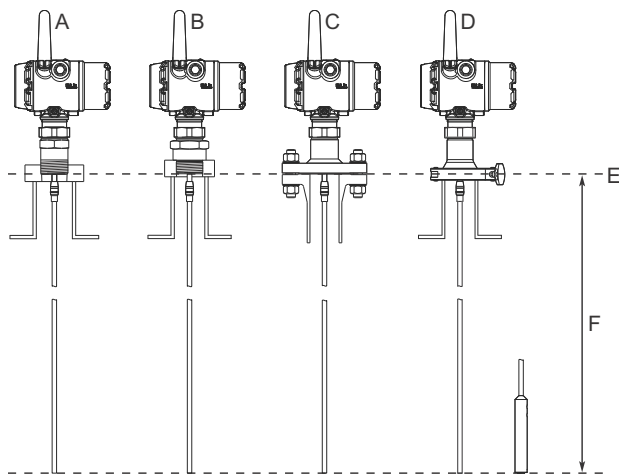

- A. NPT
- B. BSPP (G)
- C. Flange
- D. Tri Clamp
- E. Upper reference point
- F. Total probe length

Select the probe length according to the required measuring range (the probe must be hung and fully extended through the entire distance where level readings are desired).

Cut-to-fit probes

All probes can be cut in field except for the PTFE covered probe.

However, there are some restrictions for the coaxial probe: Probes over 4.1 ft. (1.25 m) can be cut up to 2 ft. (0.6 m). Shorter probes can be cut to the minimum length of 1.3 ft. (0.4 m).

Minimum and maximum probe length

Probe type	Probe length
Flexible single lead	3.3 to 55.8 ft. (1 to 17 m)
Rigid single lead (0.3 in./8 mm)	1.3 to 9.8 ft. (0.4 to 3 m)
Rigid single lead (0.5 in./13 mm)	1.3 to 19.7 ft. (0.4 to 6 m)
Segmented rigid single lead	1.3 to 32.8 ft. (0.4 to 10 m)
Flexible twin lead	3.3 to 55.8 ft. (1 to 17 m)
Coaxial	1.3 to 19.7 ft. (0.4 to 6 m)

Probe angle

0 to 90 degrees from vertical axis

Tensile strength

- 0.16 in. (4 mm) Flexible single lead SST: 2698 lb (12 kN)
- 0.16 in. (4 mm) Flexible single lead Alloy C-276: 1574 lb (7 kN)
- 0.16 in. (4 mm) Flexible single lead Alloy 400: 1124 lb (5 kN)
- 0.16 in. (4 mm) Flexible single lead Duplex 2205: 1349 lb (6 kN)
- Flexible twin lead SST: 2023 lb (9 kN)

Collapse load

- 0.16 in. (4 mm) Flexible single lead SST: 3597 lb (16 kN)
- 0.16 in. (4 mm) Flexible single lead Alloy C-276: 1798 lb (8 kN)
- 0.16 in. (4 mm) Flexible single lead Alloy 400: 1349 lb (6 kN)
- 0.16 in. (4 mm) Flexible single lead Duplex 2205: 1574 lb (7 kN)

Sideway capacity

- Rigid single lead/Segmented rigid single lead: 4.4 ft. lbf, 0.44 lb at 9.8 ft. (6 Nm, 0.2 kg at 3 m)
- Coaxial: 73.7 ft. lbf, 3.7 lb at 19.7 ft. (100 Nm, 1.67 kg at 6 m)

Material exposed to tank atmosphere**Table 13: Standard Probe (Operating Temperature and Pressure Code S)**

Material of construction code	Material exposed to tank atmosphere
1	316L/316 (EN 1.4404), PTFE, PFA, silicone grease, and O-ring materials
2 and H	Alloy C-276 (UNS N10276), PTFE, PFA, silicone grease, and O-ring materials
3	Alloy 400 (UNS N04400), Alloy K500 (UNS N05500), PTFE, PFA, silicone grease, and O-ring materials
7	PTFE (1 mm PTFE cover)
8	316L/316 (EN 1.4404), PTFE, silicone grease, and O-ring materials
D	Duplex 2205 (UNS S31803/EN 1.4462), Duplex 2507 (UNS S32750/EN 1.4410), PTFE, PFA, silicone grease, and O-ring materials

Weight

Table 14: Flange and Probes

Item	Weight
Flange	Depends on flange size
Flexible single lead probe	0.05 lb/ft. (0.08 kg/m)
Rigid single lead probe (0.3-in./8 mm)	0.27 lb/ft. (0.4 kg/m)
Rigid single lead probe (0.5-in./13 mm)	0.71 lb/ft. (1.06 kg/m)
Segmented rigid single lead probe	0.71 lb/ft. (1.06 kg/m)
Flexible twin lead probe	0.09 lb/ft. (0.14 kg/m)
Coaxial probe	0.67 lb/ft. (1 kg/m)

Table 15: End Weight

Item	Weight
Small weight (code W1)	SST probe: 0.88 lb (0.40 kg)
	PTFE covered probe: 2.20 lb (1 kg)
Short weight (code W2)	0.88 lb (0.40 kg)
Heavy weight (code W3)	2.43 lb (1.10 kg)
Weight for twin lead probe	1.3 lb (0.60 kg)

End weight and anchoring options

There are in total four weight and anchoring options for flexible single lead probes.

Small weight (code W1)

A small weight is recommended for narrow tank openings less than 1.5 in. (38 mm). Required weight option for PTFE covered probes.

Short weight (code W2)

A short weight is available for the single flexible stainless steel probe. It is recommended for maximized measuring ranges with measurements close to the probe end.

Heavy weight (code W3)

A heavy weight is the recommended choice for most applications.

Chuck (code W4)

To tie probe end to tank bottom.

Installation and mounting considerations

Free space requirement

If the probe is mounted close to a wall, nozzle or other tank obstruction, noise might appear in the level signal. Therefore the following minimum clearance, according to [Table 16](#), must be maintained.

Figure 15: Free Space Requirement

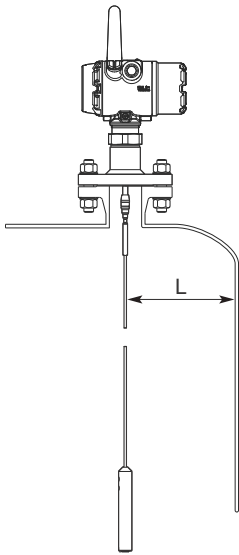

L. Clearance to tank wall

Table 16: Recommended Minimum Free Space for Optimal Performance

Probe type	Condition	Minimum clearance (L)
Rigid single lead/Segmented rigid single lead ⁽¹⁾	Smooth metal tank wall	4 in. (100 mm)
	Disturbing objects such as pipes and beams Plastic, concrete or rugged metal tank wall	16 in. (400 mm)
Flexible single	Smooth metal tank wall	4 in. (100 mm)
	Disturbing objects such as pipes and beams Plastic, concrete or rugged metal tank wall	16 in. (400 mm)
Coaxial ⁽¹⁾	N/A	0 in. (0 mm)
Flexible twin	N/A	4 in. (100 mm)

(1) Minimum clearance from tank bottom for the coaxial and rigid single probes is 0.2 in. (5 mm).

Flange connection on nozzles

Figure 16: Mounting in Nozzles

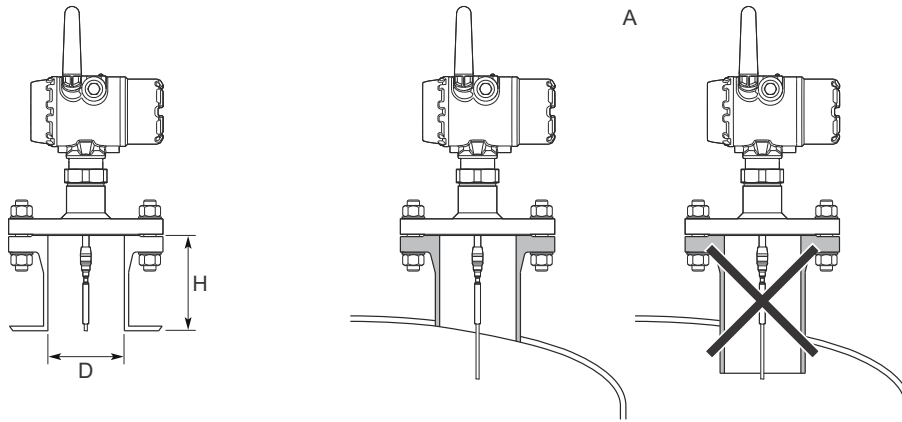

A. Confirm the nozzle does not extend into the tank.

The transmitter can be mounted in nozzles by using an appropriate flange. It is recommended that the nozzle size is within the dimensions given in Table 17.

Table 17: Nozzle Considerations for Optimal Performance

Description	Flexible single lead probe	Rigid single lead probe/Segmented rigid single lead	Flexible twin lead probe	Coaxial probe
Recommended nozzle diameter (D)	4 in. (100 mm) or more	4 in. (100 mm) or more	4 in. (100 mm) or more	> probe diameter
Minimum nozzle diameter (D) ⁽¹⁾	1.5 in. (38 mm)	1.5 in. (38 mm) for probe type 4A 2 in. (50 mm) for probe type 4B and 4S	2 in. (50 mm)	> probe diameter
Maximum nozzle height (H) ⁽²⁾	4 in. (100 mm) + nozzle diameter ⁽³⁾	4 in. (100 mm) + nozzle diameter	4 in. (100 mm) + nozzle diameter	N/A

(1) The Trim Near Zone (TNZ) function may be necessary or an Upper Null Zone (UNZ) setup may be required to mask the nozzle.

(2) Recommended maximum nozzle height. For coaxial probes there is no limitation on nozzle height.

(3) For nozzles taller than 4 in. (100 mm), the long stud version is recommended (option code LS) to prevent the flexible portion from touching the edge of the nozzle.

Note

The probe must not be in contact with the nozzle (except for the coaxial probe).

Installation in still pipe/chamber

General chamber considerations

Dimensioning the chamber/pipe correctly and selecting the appropriate probe is key to the success in these applications. When selecting a smaller chamber/pipe diameter, such as 2-in., a flexible probe is not suitable due to the chance of it coming into contact with the walls. Also, relatively large side inlets may interfere with the signal.

When gas lift and/or turbulence may occur (e.g. boiling hydrocarbons), a 3- or 4-in. chamber/pipe diameter is recommended for maximum measurement reliability. This is especially true in high pressure and high temperature installations.

Table 18: Recommended and Minimum Chamber/Still Pipe Diameters for Different Probes

Probe type	Recommended diameter	Minimum diameter
Rigid single/segmented rigid single	3 or 4 in. (75 or 100 mm)	2 in. (50 mm)
Flexible single	4 in. (100 mm)	Consult your local Emerson representative
Flexible twin ⁽¹⁾	4 in. (100 mm)	Consult your local Emerson representative
Coaxial	3 or 4 in. (75 or 100 mm)	1.5 in. (37.5 mm)

(1) The center rod must be placed more than 0.6 in. (15 mm) away from the pipe wall.

Note

Metal pipes are preferred, especially in applications with low dielectric constant, to avoid disturbances from objects near the pipe.

For more information and installation requirements, refer to the Best Practices for Using Radar in Still Pipes and Chambers [Technical Note](#).

Related information

[Dimensional drawings](#)

Rosemount chamber

A Rosemount chamber allows external mounting of process level instrumentation. It supports a variety of process connections, and optional drain and vent connections. The standard Rosemount chambers are designed according to ASME B31.3. Rosemount chambers compliant with the Pressure Equipment Directive (PED) are available. Customer specific engineered solutions for Rosemount chambers are available upon request. Use option code XC to order together with the Rosemount 3308A Series Transmitters.

Figure 17: Side-to-Side and Side-to-Bottom Chambers

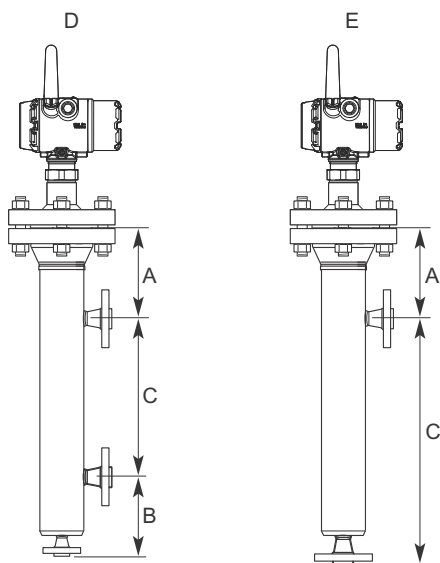

- A. Dimension A
- B. Dimension B
- C. Dimension CC
- D. Side-to-side chamber
- E. Side-to-bottom chamber

When mounting in a Rosemount chamber, see [Table 19](#) for information on probe length determination.

Table 19: Probe Length Determination for Rosemount CMB Chambers

Chamber type	Probe length
Side-to-side chamber	A + CC + B - 80 mm
Side-to-bottom chamber	A + CC - 80 mm

Use a centering disc the same diameter as the chamber if the probe length >3.3 ft. (1 m). See [Table 22](#) for which disc to use.

Existing chamber

A Rosemount 3308 Series Transmitter is the perfect replacement in an existing displacer chamber. Proprietary flanges are offered, enabling use of existing chambers to make installation easy.

Figure 18: Existing Displacer Chamber

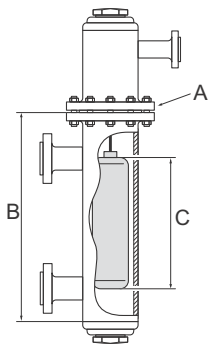

- A. Replace chamber flange
- B. Probe length
- C. Displacer length

Considerations when changing to Rosemount 3308 Series:

- The Rosemount 3308 Series flange choice and probe length must be correctly matched to the chamber. Both standard ASME and EN (DIN), as well as proprietary chamber flanges, are available. See [Proprietary flanges](#) to identify the proprietary flanges.
- See [Table 22](#) for guidelines on which disc size to use.
- See [Table 20](#) for guidelines on the required probe length.

Table 20: Required Probe Length in Chambers

Chamber manufacturer	Probe length ⁽¹⁾
Major torque-tube manufacture (249B, 249C, 249K, 249N, 259B)	Displacer + 9 in. (229 mm)
Masoneilan™ (torque tube operated), proprietary flange	Displacer + 8 in. (203 mm)
Other - torque tube ⁽²⁾	Displacer + 8 in. (203 mm)
Magnetrol® (spring operated) ⁽³⁾	Displacer + between 7.8 in. (195 mm) to 15 in. (383 mm)
Others - spring operated ⁽²⁾	Displacer + 19.7 in. (500 mm)

(1) If flushing ring is used, add the ring height to the probe length.

(2) For other manufacturers, there are small variations. This is an approximate value; actual length should be verified.

(3) Lengths vary depending on model, SG, and rating, and should be verified.

For additional information, see the Replacing Displacers with Guided Wave Radar [Technical Note](#).

Probe type in chamber considerations

When installing a Rosemount 3308A in a chamber, the single lead probe is recommended.

The probe must not touch the chamber wall, should extend the full height of the chamber, but not touch the bottom of the chamber.

The probe length determines if a single rigid or single flexible probe should be used:

- Less than 19.7 ft. (6.0 m): Rigid single probe is recommended. Use a centering disc for probe > 3.3 ft. (1 m). When mounting space is limited, use a flexible single probe with a weight and centering disc.
- More than 19.7 ft. (6.0 m): Use flexible single probe with a weight and centering disc.

Centering disc for pipe installations

To prevent the probe from contacting the chamber or pipe wall, centering discs are available for flexible single, rigid single, and flexible twin lead probes. The disc is attached to the end of the probe. Discs are made of stainless steel, Alloy C-276, Alloy 400, Duplex 2205, or PTFE.

For the segmented rigid single lead probe, up to five PTFE centering discs can be mounted along the probe, but keep a minimum distance of two segments between the discs. Additionally, a disc in SST or PTFE (part number 03300-1655-xxxx) can be attached to the end of the probe.

When mounting a centering disc, it is important that it fits correctly in the chamber/pipe. See [Figure 19](#) for Dimension D. [Table 22](#) shows which centering disc diameter to choose for a particular pipe.

Figure 19: Dimension D for Centering Discs

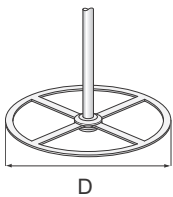

Table 21: Centering Disc Dimensions

Disc size	Actual disc diameter (D)
2-in.	1.8 in. (45 mm)
3-in.	2.7 in. (68 mm)
4-in.	3.6 in. (92 mm)
6-in.	5.55 in. (141 mm)
8-in.	7.40 in. (188 mm)

Table 22: Centering Disc Size Recommendation for Different Pipe Schedules

Pipe size	Pipe schedule			
	5s, 5 and 10s, 10	40s, 40 and 80s, 80	120	160
2-in.	2-in.	2-in.	N/A ⁽¹⁾	N/A ⁽²⁾
3-in.	3-in.	3-in.	N/A ⁽¹⁾	2-in.
4-in.	4-in.	4-in.	3-in.	3-in.
5-in.	4-in.	4-in.	4-in.	4-in.
6-in.	6-in.	6-in.	4-in.	4-in.
7-in.	N/A ⁽¹⁾	6-in.	N/A ⁽¹⁾	N/A ⁽¹⁾
8-in.	8-in.	8-in.	6-in.	6-in.

(1) Schedule is not available for pipe size.
 (2) No centering disc is available.

Installation in non-metallic tanks and open-air applications

Avoid major sources of electrical disturbance in proximity of the installation (e.g. electrical motors, stirrers, servo mechanisms).

Figure 20: Avoid Electromagnetic Disturbances

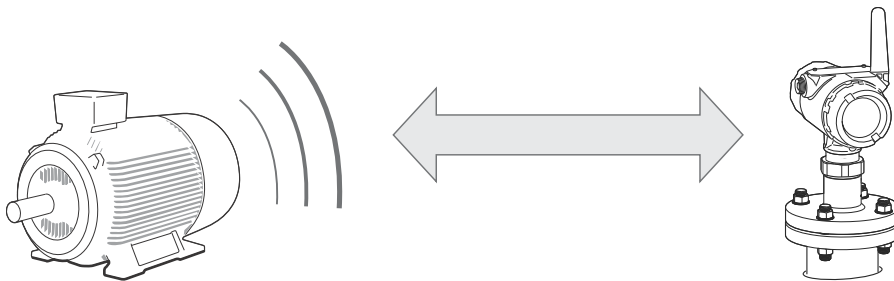

For clean liquids, use a coaxial probe to reduce effect of potential electrical disturbances.

Figure 21: Coaxial Probe in an Open-Air Application

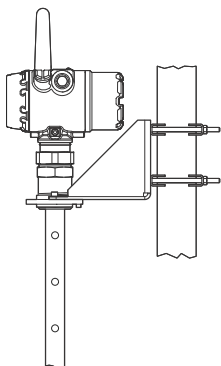

For optimal single lead probe performance in non-metallic tanks, the probe must be mounted with a metal flange, or screwed in to a metal sheet ($d > 14$ in./350 mm) if a threaded version is used.

Figure 22: Mounting in Non-Metallic Tanks

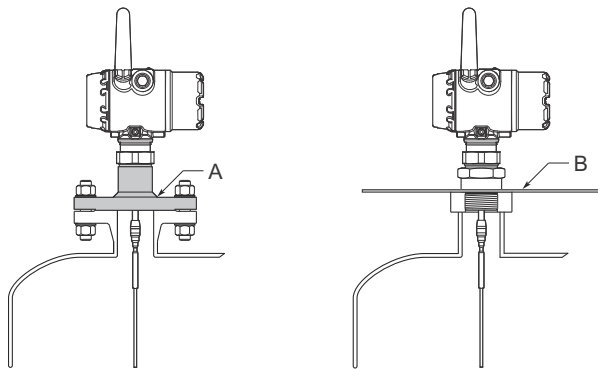

- A. Metal flange
- B. Metal sheet ($d > 14$ in./350 mm)

Minimum distance between two single probes

When installing multiple Rosemount 3308A Level Transmitters with single probes in the same tank, ensure to place the devices at proper distance from each other to avoid the risk of interference caused by cross-talk. [Table 23](#) provides recommended minimum distance between two probes. A coaxial probe or a probe installed in a still pipe will not cause any cross-talk.

Table 23: Minimum Distance between Single Probes

Product	Minimum distance between probes
Oil (DC = 2.1)	5.2 ft. (1.6 m)
Water (DC = 80)	3.3 ft. (1.0 m)

Product certifications

See the Rosemount 3308A [Product Certifications](#) document for detailed information on the existing approvals and certifications.

Dimensional drawings

Figure 23: Flexible Single Lead Probe

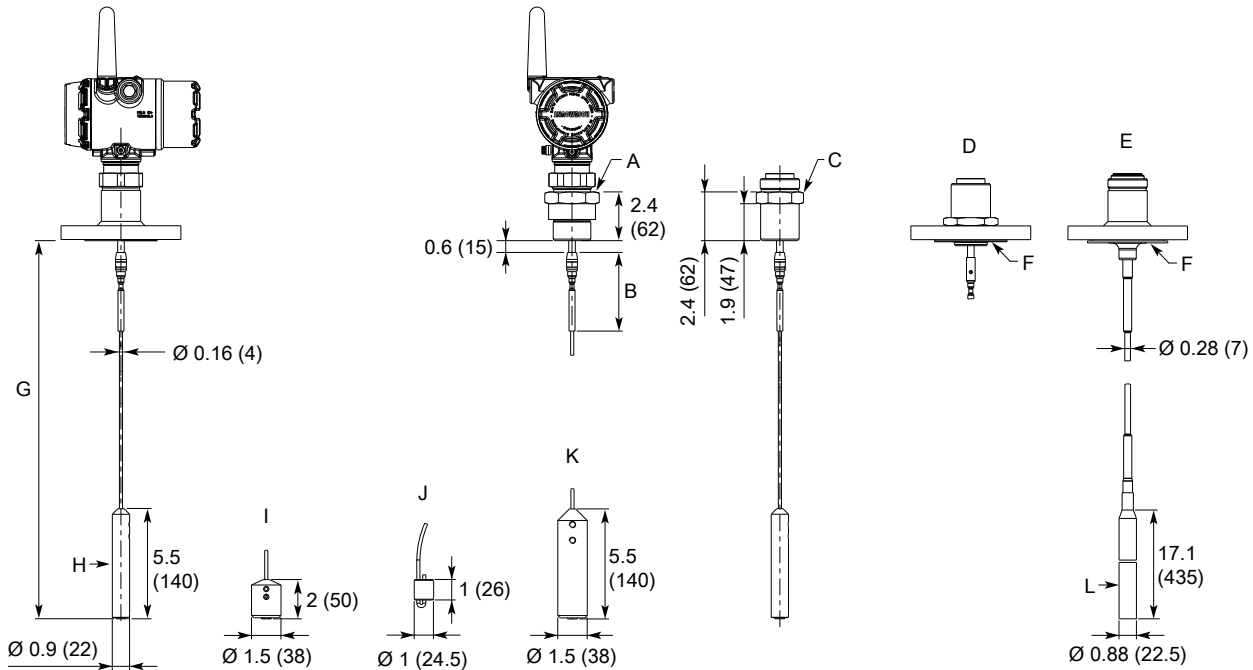

- A. BSPP (G) 1-in., s52; BSPP (G) 1½-in., s60
- B. Standard length: 4 (100); Long stud (option LS): 10 (250)
- C. NPT 1-in., s52; NPT 1½-in., s52; NPT 2-in., s60
- D. Alloy probe and protective plate
- E. PTFE covered probe and protective plate
- F. Protective plate
- G. $L \leq 56$ ft. (17 m)
- H. Small weight (option W1)
- I. Short weight (option W2)
- J. Chuck (option W4)
- K. Heavy weight (option W3)
- L. Weight for PTFE covered probe (option W1)

Dimensions are in inches (millimeters).

Figure 24: Rigid Single Lead Probe

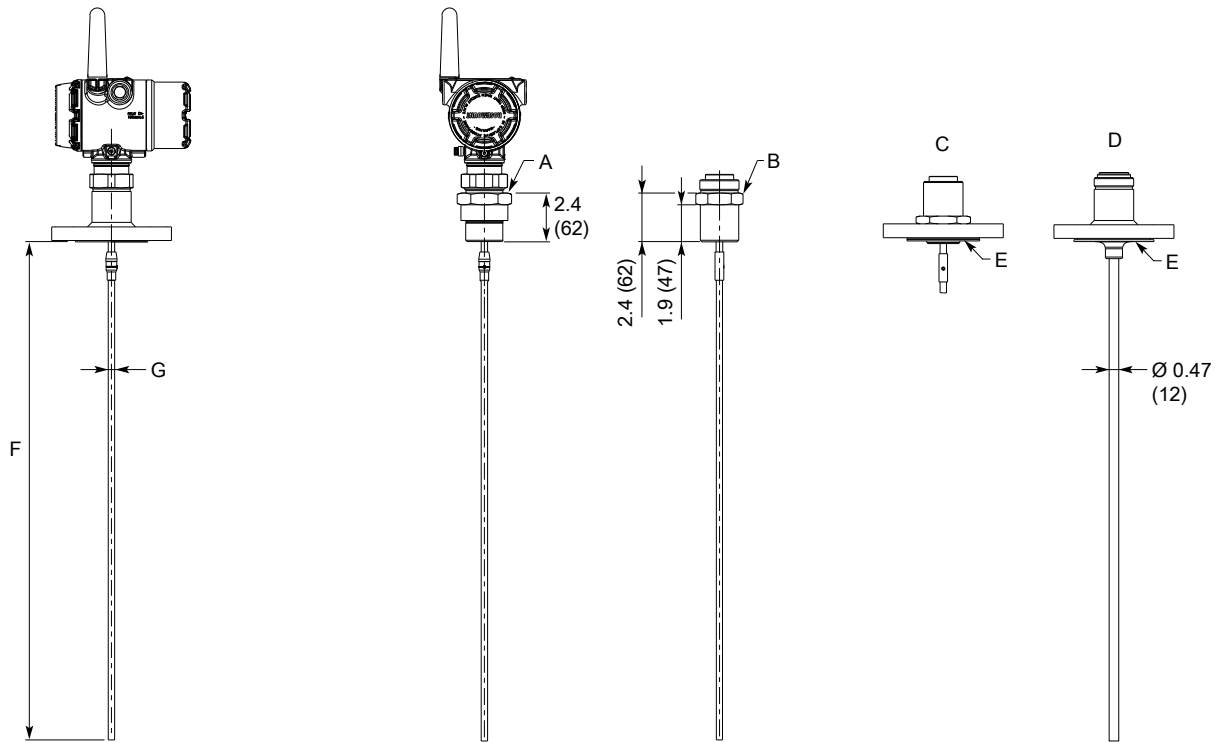

- A. BSPP (G) 1-in., s52; BSPP (G) 1½-in., s60
- B. NPT 1-in., s52; NPT 1½-in., s52; NPT 2-in., s60
- C. Alloy probe and protective plate
- D. PTFE covered probe and protective plate
- E. Protective plate
- F. $L \leq 10$ ft. (3 m) for $\varnothing 0.31$ (8); $L \leq 20$ ft. (6 m) for $\varnothing 0.51$ (13)
- G. $\varnothing 0.31$ (8) or $\varnothing 0.51$ (13)

Dimensions are in inches (millimeters).

Figure 25: Segmented Rigid Single Lead Probe

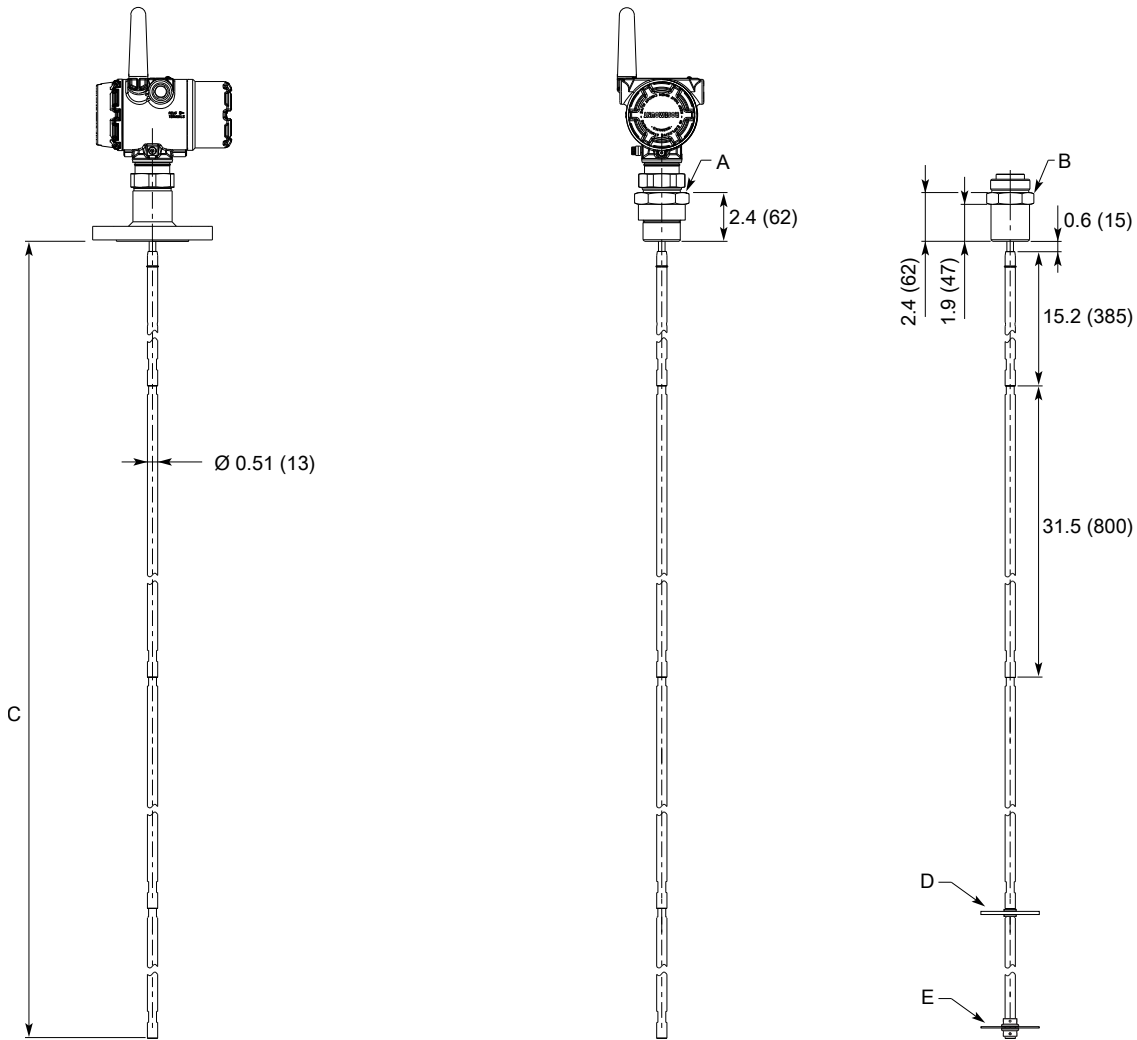

- A. BSPP (G) 1½-in., s60
- B. NPT 1-in., s52; NPT 1½-in., s52
- C. $L \leq 10 \text{ ft. (3 m)}$
- D. Optional: PTFE centering disc
- E. Optional: Bottom centering disc (SST or PTFE)

Dimensions are in inches (millimeters).

Figure 26: Coaxial Probe

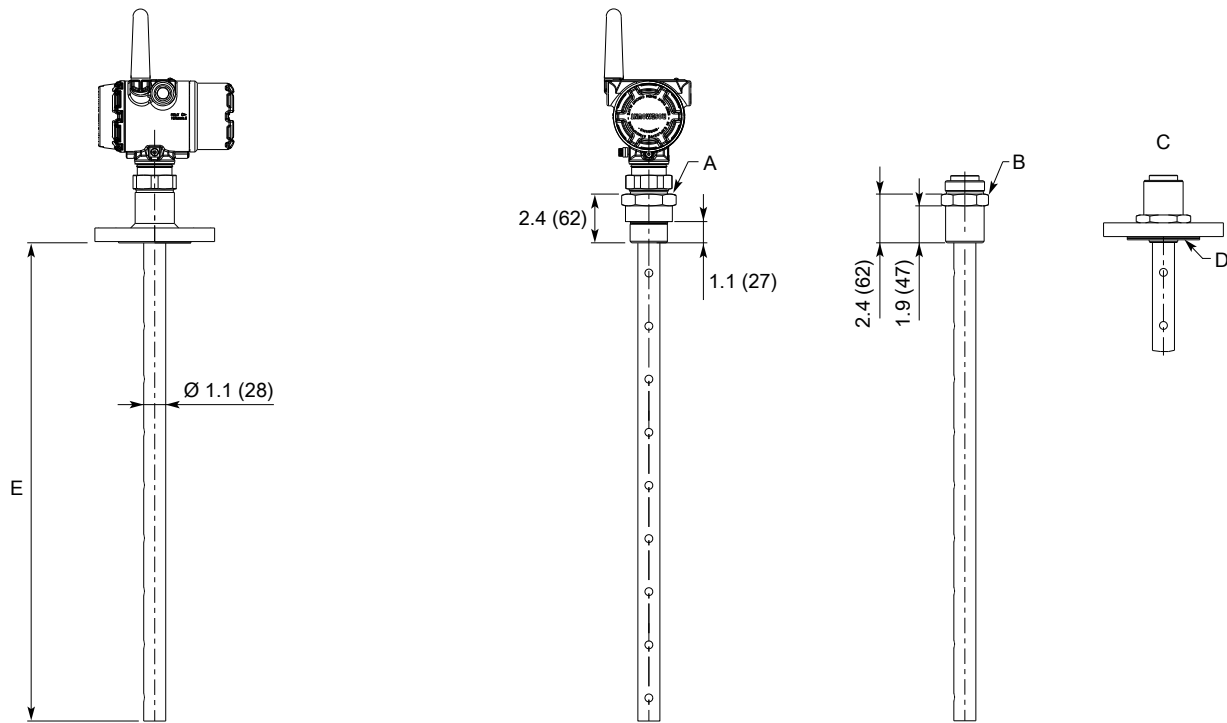

- A. BSPP (G) 1-in., s52; BSPP (G) 1½-in., s60
- B. NPT 1-in., s52; NPT 1½-in., s52; NPT 2-in., s60
- C. Alloy probe and protective plate
- D. Protective plate
- E. $L \leq 20 \text{ ft. (6 m)}$

Dimensions are in inches (millimeters).

Figure 27: Flexible Twin Lead Probe

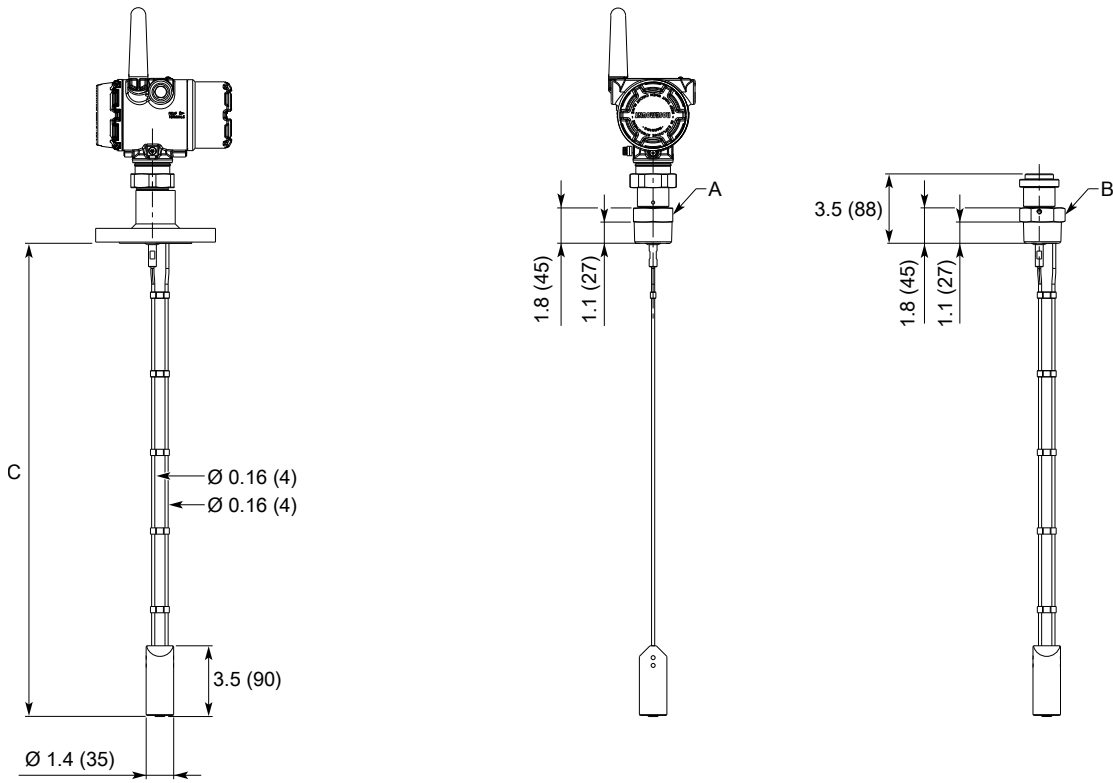

- A. BSPP (G) 1½-in., s60
- B. NPT 1½-in., s52; NPT 2-in., s60
- C. $L \leq 56$ ft. (17 m)

Dimensions are in inches (millimeters).

Figure 28: Housing and Antenna

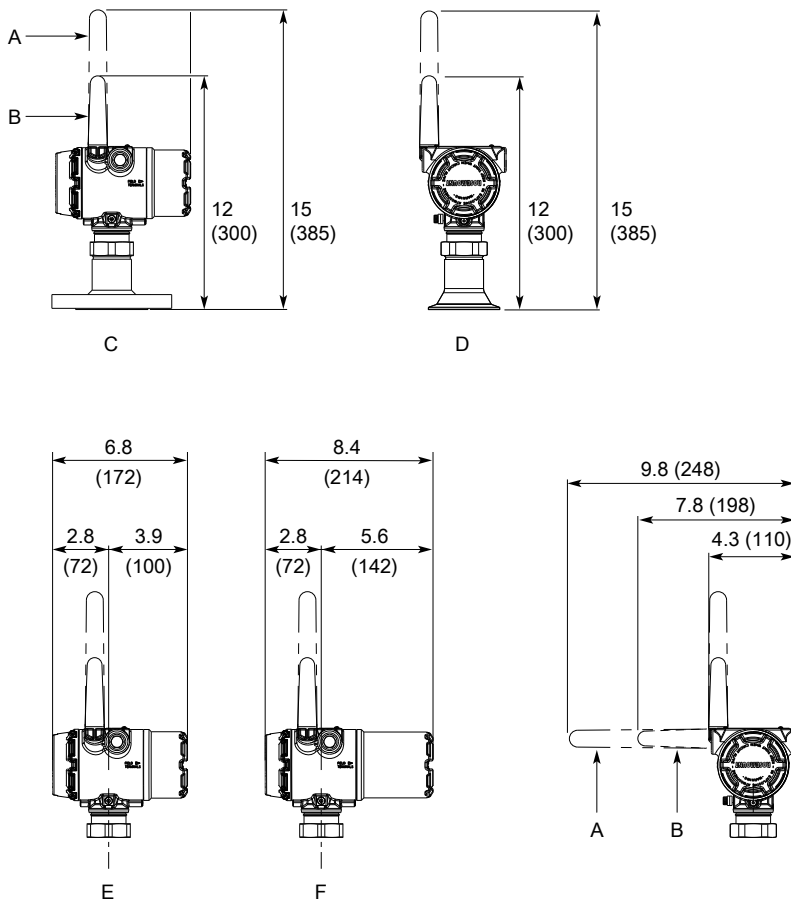

- A. *Extended range, external antenna (option WM)*
- B. *External antenna (option WK)*
- C. *Flange connection*
- D. *Tri Clamp connection*
- E. *Standard life black power module (option 1)*
- F. *Extended life blue power module (option 2)*

Dimensions are in inches (millimeters).

Figure 29: Mounting Bracket (Option Code BR)

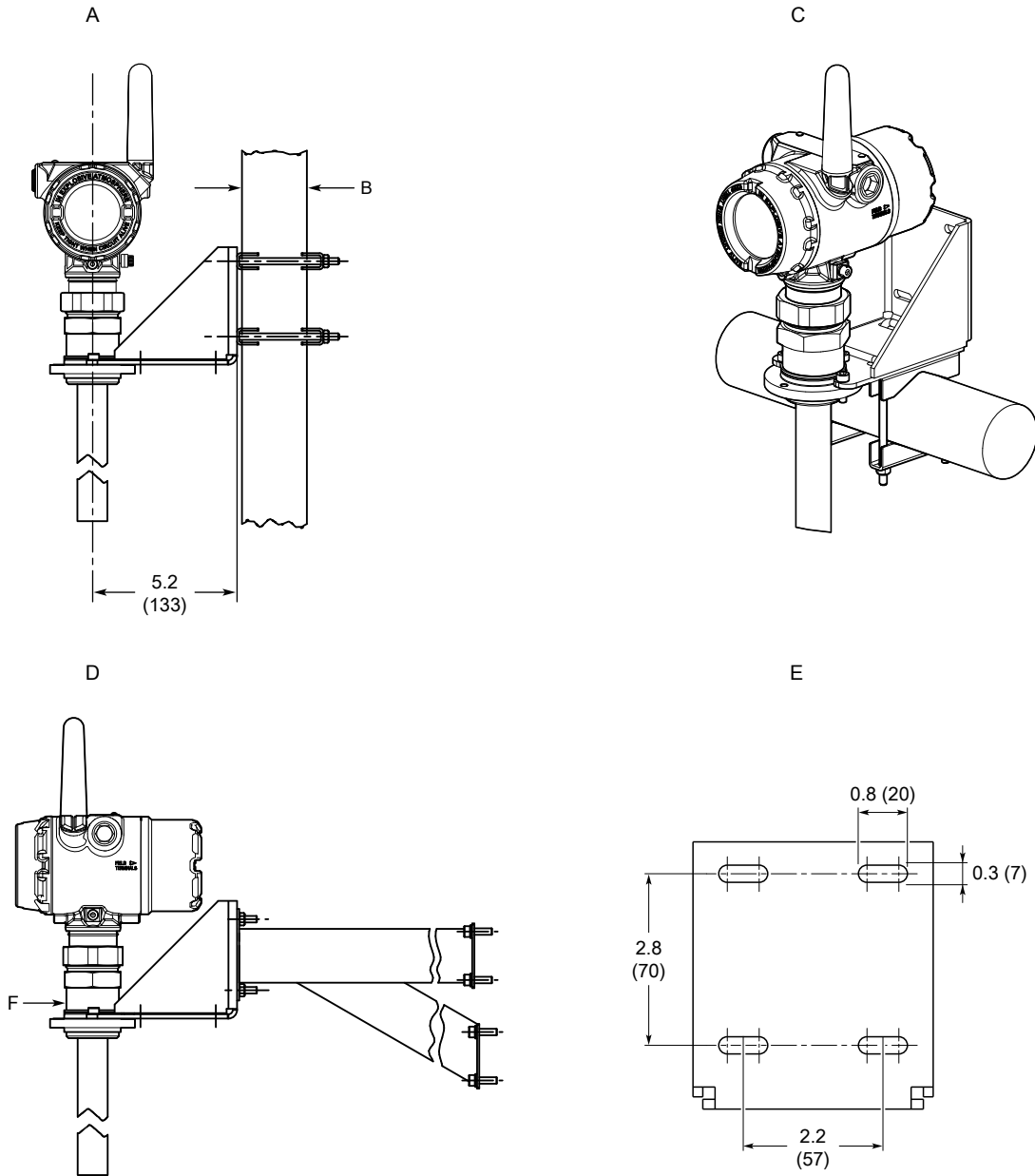

- A. Pipe mounting (vertical pipe)
- B. Pipe diameter, max 2.5 in. (64 mm)
- C. Pipe mounting (horizontal pipe)
- D. Wall mounting
- E. Hole pattern for wall mounting
- F. NPT 1 1/2-in.

Dimensions are in inches (millimeters).

Figure 30: High Gain, Remote Antenna (Option Code WN)

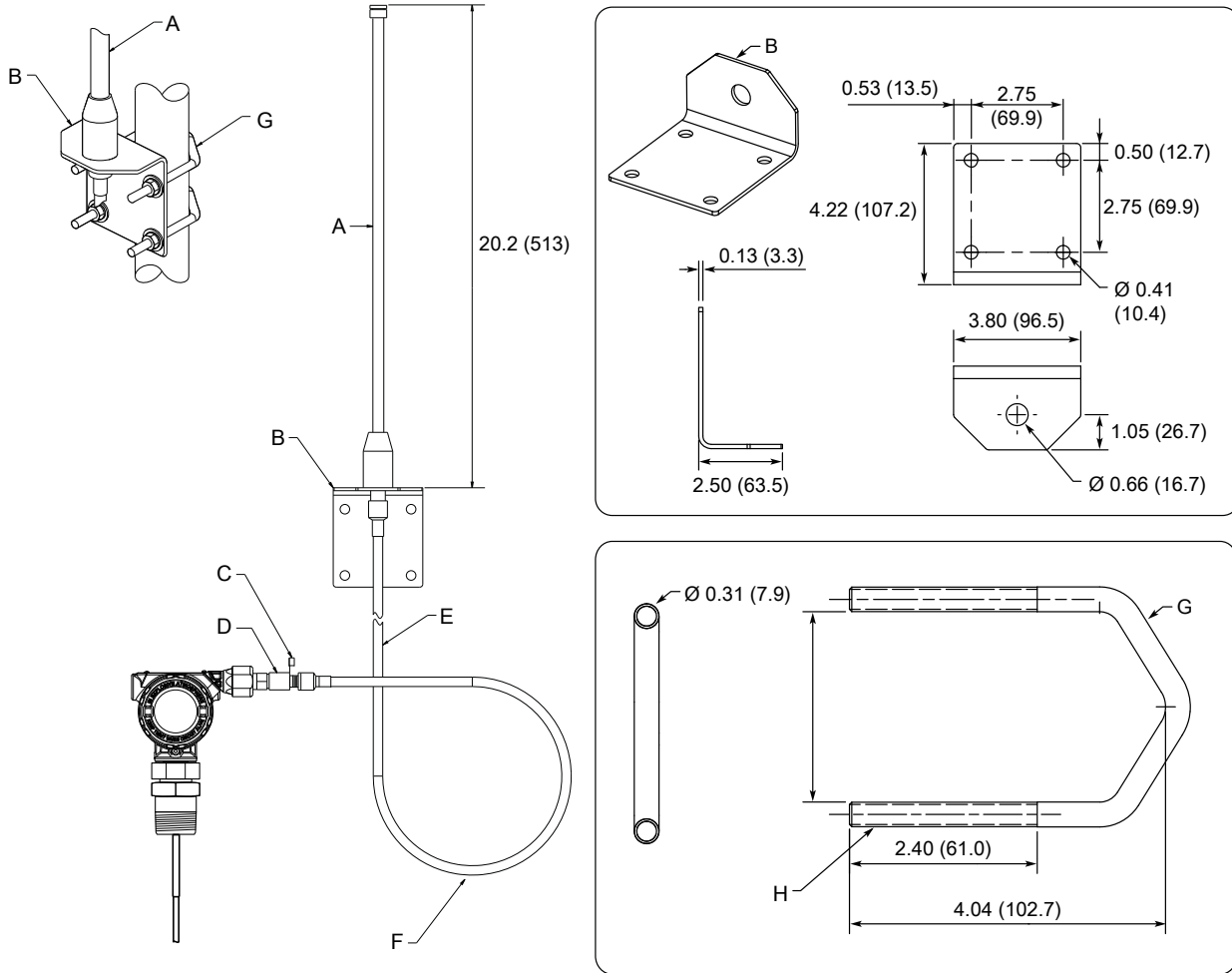

- A. Antenna
- B. Mounting bracket
- C. Ground connection point
- D. RF lightning arrester
- E. 25 ft. (7.6 m) cable
- F. Minimum drip loop: Ø12 (300)
- G. U-bolt
- H. 5/16-18 UNC-2A thread, 2PLS

Dimensions are in inches (millimeters).

Proprietary flanges

Figure 31: Proprietary Flanges

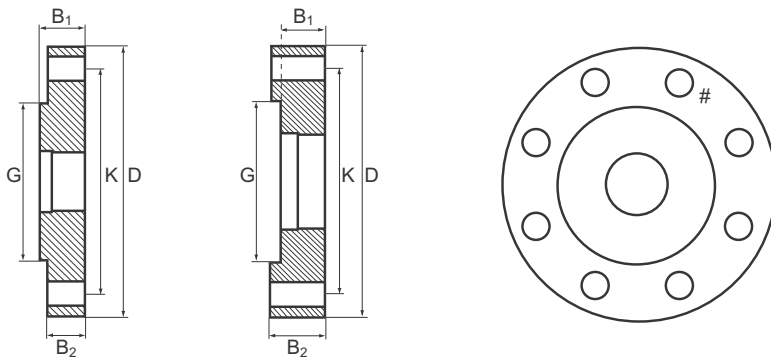

D: Outside diameter

B₁: Flange thickness with gasket surface

B₂: Flange thickness without gasket surface

F=B₁-B₂: Gasket surface thickness

G: Gasket surface diameter

Bolts: Number of bolts

K: Bolt hole circle diameter

Dimensions are in inches (millimeters).

Note

Dimensions may be used to aid in the identification of installed flanges. It is not intended for manufacturing use.

Table 24: Dimensions of Proprietary Flanges

Special flanges ⁽¹⁾	D	B ₁	B ₂	F	G	# Bolts	K
Fisher™ 249B/259B ⁽²⁾	9.00 (228.6)	1.50 (38.2)	1.25 (31.8)	0.25 (6.4)	5.23 (132.8)	8	7.25 (184.2)
Fisher 249C ⁽³⁾	5.69 (144.5)	0.94 (23.8)	1.13 (28.6)	-0.19 (-4.8)	3.37 (85.7)	8	4.75 (120.65)
Masoneilan™ ⁽²⁾	7.51(191.0)	1.54 (39.0)	1.30 (33.0)	0.24 (6.0)	4.02 (102.0)	8	5.87 (149.0)

(1) These flanges are also available in a vented version.

(2) Flange with raised face.

(3) Flange with recessed face.

For information about flange temperature and pressure ratings, see [Fisher and Masoneilan flange rating](#).

Flushing connection rings

Figure 32: Flushing Connection Rings

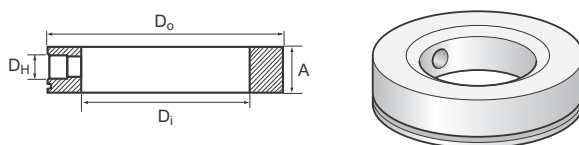

A. Height: 0.97 in. (24.6 mm)

Table 25: Dimensions of Flushing Connection Rings

Flushing connection rings	D _i	D _o	D _H
2-in. ANSI	2.12 (53.8)	3.62 (91.9)	¼-in. NPT
3-in. ANSI	3.60 (91.4)	5.00 (127.0)	¼-in. NPT
4-in. ANSI/DN100	3.60 (91.4)	6.20 (157.5)	¼-in. NPT
DN50	2.40 (61.0)	4.00 (102.0)	¼-in. NPT
DN80	3.60 (91.4)	5.43 (138.0)	¼-in. NPT

Complementary point level monitoring

An ideal complement to the Rosemount 3308, the Rosemount 2160 Wireless Level Detector provides reliable high/low level alarms and overflow protection, wirelessly communicating output and advanced instrument health.



With an update rate of up to one second, the Rosemount 2160 may be used in both monitoring and control applications. See the Rosemount 2160 [Product Data Sheet](#) for more information.

For more information: [Emerson.com](https://www.emerson.com)

©2022 Emerson. All rights reserved.

Emerson Terms and Conditions of Sale are available upon request. The Emerson logo is a trademark and service mark of Emerson Electric Co. Rosemount is a mark of one of the Emerson family of companies. All other marks are the property of their respective owners.

ROSEMOUNT™

