

# Rosemount™ 3812

## Two-Path Liquid Ultrasonic Flow Meter

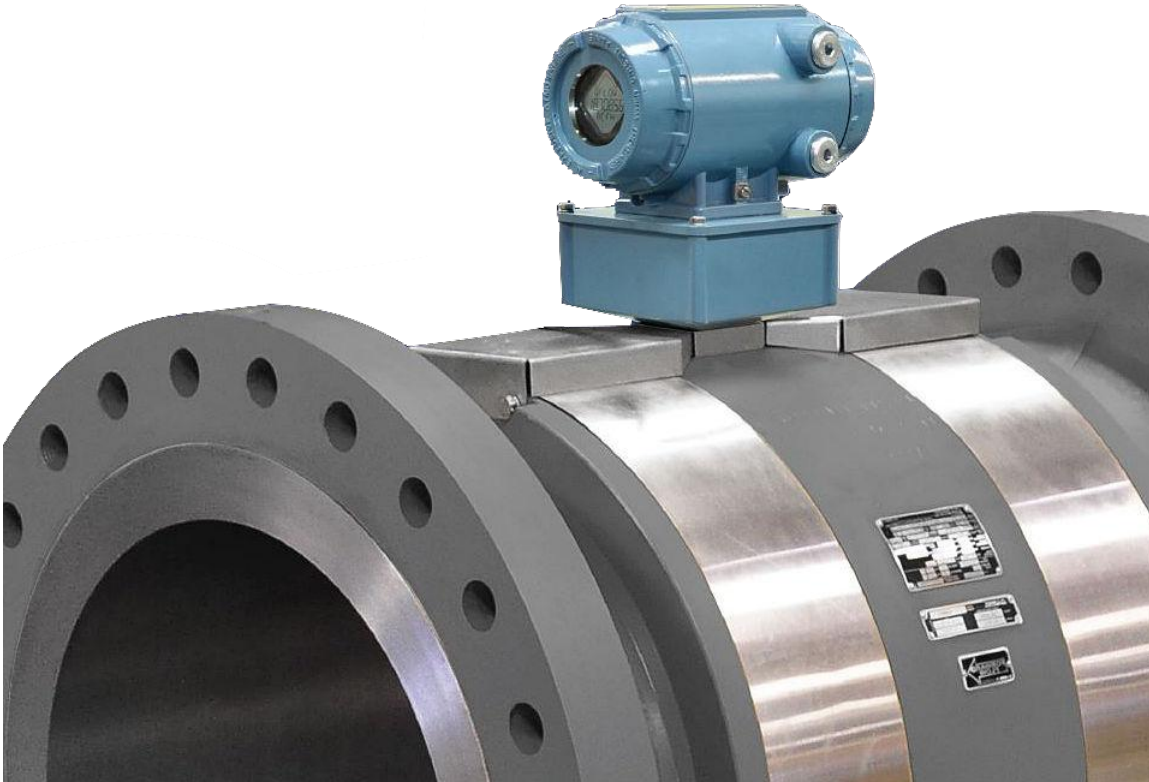

## A reliable, economical solution

The advanced Rosemount 3812 Liquid Ultrasonic Flow Meter combines a field-proven two-path meter design with innovative electronics to provide accurate, repeatable measurement for a variety of non-custody transfer applications. Available in DN100 to DN900 (4-in to 36-in) line sizes, the cost-efficient meter is easy-to-install with no need for filters, flow strainers or supports against vibrations. In addition, no moving parts eliminate wear, drift and pressure loss for reliable, long term performance.

The 3812 meter measures the transit times of ultrasonic pulses passing through the liquid in two parallel paths, downstream with the flow and upstream against the flow. Transducers are integrally mounted on the two paths in pairs with each pair acting alternately as transmitter and receiver. The difference in transit times is proportional to the measured fluid velocity along the two paths. This data is converted into an output signal and displayed as the volumetric flow rate.

Powerful Rosemount 3810 Electronics work with the meter to significantly increase the sampling rate and provide high volume data capture, including extensive hourly and daily logs to simplify auditing and dispute resolution. The streamlined electronics feature a plug-in ready, integrated CPU and I/O board assembly and a local LCD display (optional) to increase reliability, simplify maintenance and facilitate future expansion.

Operators can easily monitor and troubleshoot the 3812 meter in real time from a PC or laptop. MeterLink™ Diagnostics Software is an intuitive user interface that provides critical information, including functional, process and systematic diagnostics, to enhance reliability and reduce measurement uncertainty.

**Figure 1: Rosemount 3812 Liquid Flow Meter**



### Typical application

#### Oil and Gas Industry

- Allocation measurement
- Effluent flow measurement
- Loading and unloading

#### Pipelines

- Leak detection
- Crude and refined product flow measurement

#### Terminal

- Loading and offloading
- Tank farms/storage measurement

#### Industrial Processes

- Batch and blending processes
- Cooling water measurement
- Plant utilities and offtake measurement

## Features and benefits

- Full bore design eliminates incremental pressure drop and reduces energy costs
- No moving parts reduce maintenance costs
- Non-wetted transducers allow field replacement
- Measurement stability improves process control
- Wide flow range provides design flexibility
- Bi-directional flow capabilities simplify installation
- Integrated diagnostics monitor meter performance
- 3810 Series Electronics provide fast sampling and output, an expandable electronics platform, and an extensive data log
- Local LCD display (optional) with up to ten user selectable scrolling variables
- MeterLink Diagnostics Software allows access to expert flow analysis and provides an intuitive view of meter health
- Wireless HART® and Ethernet for easy integration
- Predictive diagnostics are communicated and variable information is processed allowing plant personnel to quickly detect and respond to abnormal situations to avoid process upsets and unscheduled downtime
- The 3812 Liquid Ultrasonic Meter is part of Emerson's broad range of intelligent field devices that power the PlantWeb™ digital plant architecture

## Standard specifications

Consult factory on sizes above DN 900 (36-in) and on pressure ratings greater than PN 150 (ANSI 900).

Please consult a Rosemount technical specialist if requirements are outside of the listed specifications. Improved performance for other product and material offerings may be available depending on the application.

## Material specifications

### Body and Flange

- **Cast**
  - ASTM A352 Gr LCC carbon steel<sup>(1)</sup> -50°F to 302°F (-46°C to 150°C)
  - ASTM A351 Gr CF8M 316 stainless steel -50°F to 302°F (-46°C to 150°C)
  - ASTM A995 Gr 4A duplex stainless steel<sup>(2)</sup> -58°F to 302°F (-50°C to 150°C)
- **Forgings**
  - ASTM A350 Gr LF2 carbon steel<sup>(1)</sup> -50°F to 302°F (-46°C to 150°C)
  - ASTM A182 Gr F316 SS -50°F to 302°F (-46°C to 150°C)
  - ASTM A182 Gr F51 duplex SS -58°F to 302°F (-50°C to 150°C)
  - ASTM A105 carbon steel -20°F to 302°F (-29° C to 150°C)

### Enclosure Housing

- ASTM B26 Gr A356.0 T6 aluminum
- ASTM A351 Gr CF8M stainless steel

### Transducer Components

- **Transducer Housing O-ring**
  - Standard: Nitrile Butadiene Rubber (NBR)
  - Other materials available Transducer Housing
  - ASTM A479 316L stainless steel with proprietary matching layer material
  - INCONEL ASTM B446 (UNS N06625) Gr 1 (optional)
- **Shroud Material**
  - ASTM A240 316 stainless steel
- **Cable Gland**
  - Chloroprene / Nitrile Rubber

## Electronics performance

### Power

- 10.4 to 36 VDC
- 8 watts typical; 15 watts maximum

## Meter mechanical ratings

### Line sizes

- DN100 to DN900 (4-in to 36-in)<sup>(3)</sup>

### Operating Product Temperature

---

(1) Impact tested per specified ASTM standard.

(2) A995 4A material is not available in Canada.

(3) Consult factory on sizes above DN 900 (36-in) and on pressure ratings greater than PN 150 (ANSI 900).

- -58°F to +302°F (-50°C to +150°C)<sup>(4)</sup>

#### Operating Pressure Range

- 0 to 155 Bar (0 to 2,250 psig)

#### Flanges<sup>(5)</sup>

- Raised Face and Ring Type Joint (RTJ) for PN ANSI Classes 150, 300, 600 and 900 (PN 20, 50, 100 and 150)<sup>(4)</sup>

#### NACE and Norsok Compliance

- Designed for NACE compliance<sup>(5)</sup>
- Norsok available upon request

## Electronics ratings

#### Operating Temperature

- -40 to +140°F (-40 to +60°C)

#### Operating Relative Humidity

- Up to 95% non-condensing

#### Storage Temperature

- -58°F to +185°F (-50°C to +85°C)

#### Electronic Housing Options

- Integral mount (standard)
- Remote mount (optional) with 4.6 m (15 ft) cable
  - Required for process temperature above +140°F (+60°C)

## Materials of construction

The materials of construction are dependent upon application requirements that must be specified by the customer. If needed, an Emerson representative can provide material guidance.

## Material specifications

#### Body and Flange

- **Cast**
  - ASTM A352 Gr LCC carbon steel<sup>(6)</sup> -50°F to 302°F (-46°C to 150°C)
  - ASTM A351 Gr CF8M 316 stainless steel -50°F to 302°F (-46°C to 150°C)
  - ASTM A995 Gr 4A duplex stainless steel<sup>(7)</sup> -58°F to 302°F (-50°C to 150°C)
- **Forgings**
  - ASTM A350 Gr LF2 carbon steel<sup>(6)</sup> -50°F to 302°F (-46°C to 150°C)

---

(4) Dependant on material selection.

(5) It is the equipment user's responsibility to select the materials suitable for the intended services.

(6) Impact tested per specified ASTM standard.

(7) A995 4A material is not available in Canada.

- ASTM A182 Gr F316 SS -50°F to 302°F (-46°C to 150°C)
- ASTM A182 Gr F51 duplex SS -58°F to 302°F (-50°C to 150°C)
- ASTM A105 carbon steel -20°F to 302°F (-29° C to 150°C)

**Enclosure Housing**

- ASTM B26 Gr A356.0 T6 aluminum
- ASTM A351 Gr CF8M stainless steel

**Transducer Components**

- **Transducer Housing O-ring**
  - Standard: Nitrile Butadiene Rubber (NBR)
  - Other materials available Transducer Housing
  - ASTM A479 316L stainless steel with proprietary matching layer material
  - INCONEL ASTM B446 (UNS N06625) Gr 1 (optional)
- **Shroud Material**
  - ASTM A240 316 stainless steel
- **Cable Gland**
  - Chloroprene / Nitrile Rubber

## Paint specifications

**Body and Flange**

- **Carbon Steel Body**
  - 2 coat paint; zinc primer and acrylic lacquer topcoat (standard)
- **Stainless Steel or Duplex Body**
  - Paint (Optional)

**Enclosure Housing**

- **Aluminum**
  - Chromate conversion coated with a polyurethane enamel
- **Stainless Steel**
  - Passivated (Unpainted)

**Table 1: Body and Flange Maximum Pressure Ratings US Customary Units**

Body and Flange Maximum Pressure Ratings US Customary Units <sup>(1)</sup>			
Nominal Meter Size (in)	ANSI	Carbon Steel	316 Stainless Steel
4 to 36	150	290	275
	300	750	720
	600	1500	1440
	900	2250	2160

(1) Pressure rating information is for -20°F to +100°F. Other temperatures may reduce the maximum pressure rating of the materials.

**Table 2: Body and Flange Maximum Pressure Ratings Metric Units**

Body and Flange Maximum Pressure Ratings Metric Units <sup>(1)</sup>			
Nominal Meter Size (DN)	PN	Carbon Steel	316 Stainless Steel
100 to 900	20	20.0	19.0
	50	51.7	49.6
	100	103.4	99.3
	150	155.1	148.9

(1) Pressure rating information is for -29°C to +38°C. Other temperatures may reduce the maximum pressure rating of the materials.

## Standard flow ranges

**Table 3: Rosemount 3812 Flow Ranges US Customary Units**

Rosemount 3812 Flow Ranges US Customary Units											
Nominal Meter Size (in)	Meter I.D. (in)	Pipe Schedule	Fluid Velocity (ft/s)			Flow Rate (BPH)			Flow Rate (GPM)		
			Min	Max	Over-Range	Min	Max	Over-Range	Min	Max	Over-Range
4	4.026	Sch 40	2	40	48	113	2,267	2,721	79	1,587	1,905
6	6.065	Sch 40	2	40	48	257	5,146	6,175	180	3,602	4,322
8	7.981	Sch 40	2	40	48	446	8,910	10,692	312	6,237	7,485
10	10.020	Sch 40	2	40	48	702	14,045	16,853	492	9,831	11,797
12	11.938	Sch 40	2	40	48	997	19,936	23,923	698	13,955	16,746
14	13.124	Sch 40	2	40	48	1,205	24,094	28,913	843	16,866	20,239
16	15.000	Sch 40	2	40	48	1,574	31,474	37,769	1,102	22,032	26,438
18	16.876	Sch 40	2	40	48	1,992	39,839	47,807	1,394	27,887	33,465
20	18.812	Sch 40	2	40	48	2,475	49,504	59,405	1,733	34,653	41,583
24	22.624	Sch 40	2	40	48	3,580	71,599	85,920	2,506	50,120	60,144
30	29.25	STD	2	40	48	5,984	119,680	143,617	4,189	83,776	100,531
36	35.25	STD	2	40	48	8,691	173,816	208,580	6,084	121,671	146,005

Table 4: Rosemount 3812 Flow Ranges Metric Units

Rosemount 3812 Flow Ranges Metric Units								
Nominal Meter Size (DN)	Meter I.D. (mm)	Pipe Schedule	Fluid Velocity (m/s)			Flow Rate (m <sup>3</sup> /hr)		
			Min	Max	Over-Range	Min	Max	Over-Range
100	102.3	Sch 40	0.61	12.2	14.6	18	360	433
150	154.1	Sch 40	0.61	12.2	14.6	41	818	982
200	202.7	Sch 40	0.61	12.2	14.6	71	1,417	1,700
250	254.5	Sch 40	0.61	12.2	14.6	112	2,233	2,679
300	303.2	Sch 40	0.61	12.2	14.6	158	3,170	3,803
350	333.4	Sch 40	0.61	12.2	14.6	192	3,831	4,597
400	381.0	Sch 40	0.61	12.2	14.6	250	5,004	6,005
450	428.65	Sch 40	0.61	12.2	14.6	317	6,334	7,601
500	477.82	Sch 40	0.61	12.2	14.6	394	7,871	9,445
600	574.65	Sch 40	0.61	12.2	14.6	569	11,383	13,660
750	742.95	STD	0.61	12.2	14.6	951	19,028	22,833
900	895.35	STD	0.61	12.2	14.6	1,382	27,635	33,162

## Local LCD display

The 3810 Series Electronics offer an optional local LCD display that utilizes three lines to indicate the variable name, variable value and engineering units. The local display configuration is supported via MeterLink software or the handheld AMS Trex Device utilizing the HART interface protocol.

The local display shows up to 10 items which are user selectable from 26 variables. The display can be configured to scale volume units as actual or 000's, with an adjustable time base of seconds, hours or days. The scroll rate can be adjusted from 1 to 100 seconds (default 5 seconds).



Figure 2: Local LCD display



Table 5: User Selectable Display Variables

Variables	Description
Volumetric Flow Rate	Uncorrected (actual) Corrected (standard or normal)
Average Flow Velocity	(no description necessary)
Average Speed of Sound	(no description necessary)
Pressure	Flowing, if utilized
Temperature	Flowing, if utilized
Frequency Output	1A, 1B, 2A or 2B
Frequency Output K-factor	Channel 1 or 2
Analog Output	1 or 2
Current Day's Volume Totals	Uncorrected or Corrected (forward or reverse)
Previous Day's Volume Totals	Uncorrected or Corrected (forward or reverse)
Total Volume Totals (non-reset)	Uncorrected or Corrected (forward or reverse)

## Input/Output

**Table 6: CPU Module I/O Connections (maximum wire gauge is 18 AWG)**

	CPU Module I/O Connections (maximum wire gauge is 18 AWG)		
	I/O Connection Type	Qty	Description
Serial Communications	Serial RS-232/RS-485 Port	1	<ul style="list-style-type: none"> <li>■ Modbus RTU/ASCII</li> <li>■ 115 kbps baud rate</li> <li>■ RS-232/RS-485 Full Duplex</li> <li>■ RS485 Half Duplex</li> </ul>
	Ethernet Port (TCP/IP) 100BaseT	1	<ul style="list-style-type: none"> <li>■ Modbus TCP</li> </ul>
Digital Input <sup>(1)</sup>	Contact Closure	1	<ul style="list-style-type: none"> <li>■ Status</li> <li>■ Single polarity</li> </ul>
Analog Inputs <sup>(2)(3)</sup>	4-20 mA	2	<ul style="list-style-type: none"> <li>■ AI-1 Temperature<sup>(4)</sup></li> <li>■ AI-2 Pressure<sup>(4)</sup></li> </ul>
Frequency/Digital Outputs	TTL/Open Collector	5	<ul style="list-style-type: none"> <li>■ User Configurable (can configure Digital Input as 6th Frequency/Digital Output)</li> </ul>
Analog Output <sup>(2)</sup>	4-20 mA	1	<ul style="list-style-type: none"> <li>■ Independently configurable analog output</li> <li>■ HART® 7 Compliant, consult factory for HART® 5</li> </ul>

- (1) The analog-to-digital conversion accuracy is within ±0.05% of full scale over the operating temperature range.
- (2) A 24 volt DC power supply is available to provide power to the sensors.
- (3) The analog output zero scale offset error is within ±0.1% of full scale and gain error is within ±0.2% of full scale. The total output drift is within ±50 ppm of full scale per °C.
- (4) AI-1 and AI-2 are electronically isolated and operate in sink mode. The input contains a series resistance for HART® Communicators to be connected for sensor configuration.

**Table 7: Optional I/O Expansion Module**

	Optional I/O Expansion Module		
	I/O Connection Type	Qty	Description
Serial Communications	Serial RS-232/RS-485 Port	1	<ul style="list-style-type: none"> <li>■ Modbus RTU/ASCII</li> <li>■ 115 kbps baud rate</li> <li>■ RS-232/RS-485 Half Duplex</li> </ul>
	Ethernet Port	1	<ul style="list-style-type: none"> <li>■ 100BaseT</li> <li>■ Three Ports</li> </ul>
Analog Output	4-20mA	1	<ul style="list-style-type: none"> <li>■ Reserved for future use</li> </ul>

## Meter software

### MeterLink Overview

Innovative MeterLink software gives users access to extensive diagnostic information, presented in an intuitive graphical format that takes complexity out of flow measurement.

This critical information empowers staff to work predictively, instead of reactively.

- MeterLink software is supplied with meter at no charge
- MeterLink is required for transmitter configuration
- MeterLink software requires RS-232, RS-485 full duplex or Ethernet (recommended)
- Supports Microsoft® Windows 7, 8.1 and 10 as well as Microsoft® Office 2010-20109

**Table 8: MeterLink Features**

MeterLink Features	
Powerful Analysis	<ul style="list-style-type: none"> <li>■ View, analyze and save waveforms</li> <li>■ Daily and hourly alarm logs and audit history retrieval in Excel or CSV files</li> <li>■ Daily (5 years) and hourly (180 days) log graphing</li> <li>■ Reverse flow alert display</li> <li>■ Alarms list primary cause first</li> <li>■ Separate latched alarm display</li> <li>■ Trend maintenance logs</li> <li>■ Compare meter configurations stored in Excel logs</li> <li>■ Calibrate analog inputs</li> </ul>
Intuitive Interface	<ul style="list-style-type: none"> <li>■ Summarized and detailed views for meter performance information</li> <li>■ Built-in maintenance logs and inspection reports</li> <li>■ Meter directory support</li> <li>■ View multiple graphs simultaneously</li> <li>■ Automatic file naming and organized saving, supports hundreds of meters</li> </ul>
Quick Startup	<ul style="list-style-type: none"> <li>■ Easy upgrade of meter firmware</li> <li>■ Modbus and HART configuration</li> <li>■ Field setup wizard</li> <li>■ Local display setup</li> </ul>
Versatile Connectivity	<ul style="list-style-type: none"> <li>■ Ethernet</li> <li>■ Serial port</li> <li>■ Modem</li> </ul>

### PlantWeb

- Meters also configurable with AMS™ Device Manager or AMS Trex Device if HART® is used

## Safety and compliance

The Rosemount 3812 liquid ultrasonic flow meter meets worldwide industry standards for electrical and intrinsic safety certifications and approvals. Consult a Rosemount technical specialist for a complete list of agencies and certifications.

### Safety classifications

#### Underwriters Laboratories (UL / cUL)

- Hazardous Locations — Class I, Division 1, Groups C and D

#### CE Marked to Directives

- Explosive Atmospheres (ATEX)
- Certificate — Demko II ATEX 1006133X
- Marking —  II 2G Ex d ia IIB T4 Gb (-40°C ≤ T ≤ +60°C)
- Pressure Equipment Directive (PED)
- Electromagnetic Compatibility (EMC)

#### INMETRO

- Certificate — NCC 11.0163 X
- Marking — Ex d [ia] IIB T4 Gb IP66W

#### International Electrotechnical Commission (IECEX)

- Marking — Ex d ia IIB T4

**Figure 3: Aluminum enclosure for 3810 Series Electronics with optional display**



## Environmental ratings

### Aluminum

- NEMA<sup>®</sup> 4
- IP66 to EN60529

### Stainless Steel

- NEMA<sup>®</sup> 4X
- IP66 to EN60529

# Weights and dimensions

Figure 4: Meter Dimension Key

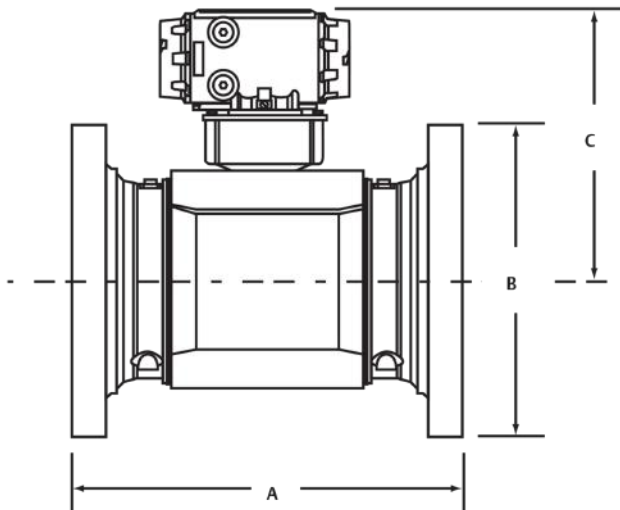

See [Table 9](#) and [Table 10](#).

Figure 5: Side View of Banded 3812 Meter (12-in and larger meters only)

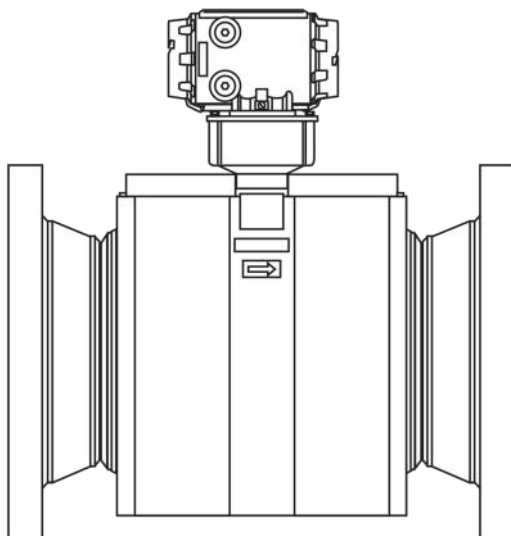
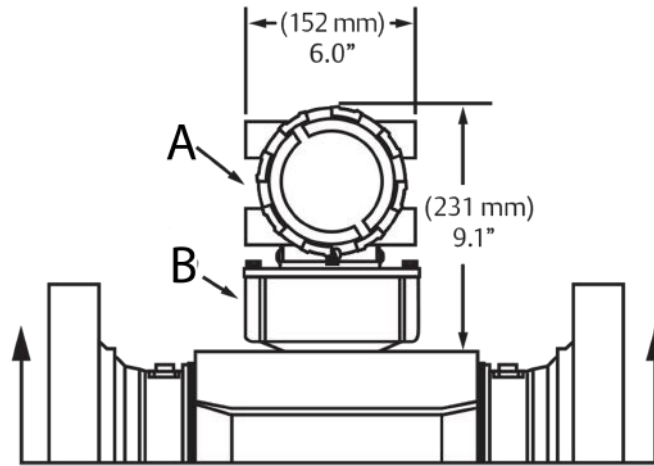
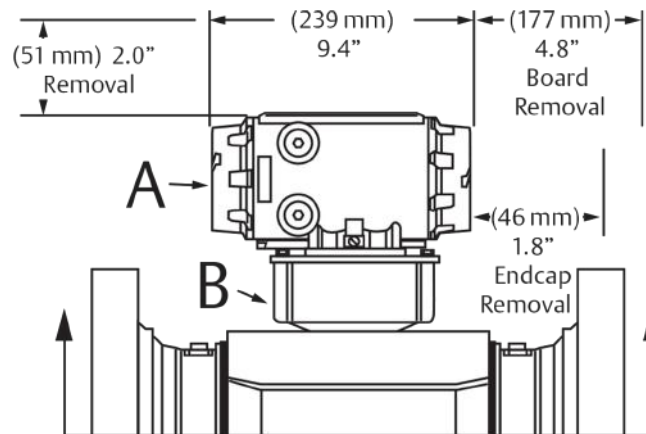

Figure 6: Standard installed position of enclosure housing<sup>(8)(9)</sup>



- A. Enclosure housing
- B. Enclosure base

Figure 7: Optional installed position of enclosure housing<sup>(9)</sup>



- A. Enclosure housing
- B. Enclosure base

## Tables

The Meter Dimension Key diagram (Figure 4) illustrates the meter component measurements that correspond to A, B and C in the chart below. Weights and dimensions are only for factory standard carbon steel material. Consult factory for all other materials. Certified approval drawings will include the actual weights and dimensions.

(8) Enclosure housing may be rotated 360 degrees in 90 degree increments.  
 (9) 4-in to 10-in meter body shown

Table 9: Weights and Dimensional Data [US Customary Units]

Weights and Dimensional Data [US Customary Units]													
Nominal Line Size (in)		4"	6"	8"	10"	12"	14"	16"	18"	20"	24"	30"	36"
150 ANSI	Weight (lb)	98	133	181	256	894	1034	1224	1486	1797	2217	2230	3480
	A (mm)	13.78	14.00	16.00	19.69	27.00	29.00	31.00	32.50	34.13	38.00	28.00	31.13
	B (mm)	9.00	11.00	13.50	16.00	19.00	21.00	23.50	25.00	27.50	32.00	38.75	46.00
	C (mm)	12.17	13.33	14.30	15.30	18.96	19.58	20.33	21.46	22.33	24.20	27.58	31.21
300 ANSI	Weight (lb)	116	163	230	320	1006	1204	1437	1778	2140	2917	3135	4855
	A (mm)	13.78	14.00	16.00	19.69	28.25	30.25	32.50	34.00	35.50	39.25	34.25	39.75
	B (mm)	13.78	12.50	15.00	17.50	20.50	23.00	25.50	28.00	30.50	36.00	43.00	50.00
	C (mm)	12.17	13.33	14.30	15.30	18.96	19.58	20.33	21.46	22.33	24.20	27.58	31.21
600 ANSI	Weight (lb)	179	314	449	664	1184	1356	1715	2094	2569	3613	3925	5905
	A (mm)	16.50	18.75	21.75	24.75	30.75	32.50	35.50	36.50	38.25	42.50	37.75	43.50
	B (mm)	10.75	14.00	16.50	20.00	22.00	23.75	27.00	29.25	32.00	37.00	44.50	51.75
	C (mm)	14.08	15.14	16.08	17.08	18.96	19.58	20.33	21.46	22.33	24.20	27.58	31.21
900 ANSI	Weight (lb)	204	374	574	834	1489	1640	1964	2544	3149	5168	5870	9475
	A (mm)	17.50	20.50	24.00	27.25	35.50	36.50	38.00	40.50	43.50	49.50	44.75	51.75
	B (mm)	11.50	15.00	18.50	21.50	24.00	25.25	27.75	31.00	33.75	41.00	48.50	57.50
	C (mm)	14.08	15.14	16.08	17.08	18.96	19.58	20.33	21.46	22.33	24.20	27.58	31.21

Table 10: Weights and Dimensional Data [Metric Units]

Weights and Dimensional Data [Metric Units]													
Nominal Line Size (DN)		100	150	200	250	300	350	400	450	500	600	750	900
PN 20	Weight (kg)	44	60	82	116	406	469	555	678	818	1136	1012	1579
	A (mm)	350	356	406	500	686	737	787	826	867	965	711	791
	B (mm)	229	279	343	406	483	533	597	635	699	813	984	1168
	C (mm)	309	339	363	389	482	497	516	545	567	615	701	793
PN 50	Weight (kg)	53	74	104	145	442	546	655	809	977	1323	1422	2202
	A (mm)	350	356	406	500	718	768	826	864	902	997	870	1010
	B (mm)	254	318	381	445	521	584	648	711	775	914	1092	1270
	C (mm)	309	339	363	389	482	497	516	545	567	615	701	793
PN 100	Weight (kg)	81	142	204	301	537	619	782	950	1168	1635	1780	2678



**Table 10: Weights and Dimensional Data [Metric Units] (continued)**

Weights and Dimensional Data [Metric Units]													
Nominal Line Size (DN)		100	150	200	250	300	350	400	450	500	600	750	900
	A (mm)	419	476	552	629	781	826	902	927	972	1080	959	1105
	B (mm)	273	356	419	508	559	603	686	743	813	940	1130	1314
	C (mm)	358	384	408	434	482	497	516	545	567	615	701	793
PN 150	Weight (kg)	93	170	260	378	669	746	891	1154	1431	2306	3062	4298
	A (mm)	445	521	610	692	902	927	965	1029	1105	1257	1168.40	1314
	B (mm)	292	381	470	546	610	641	705	787	857	1041	1231.90	1461
	C (mm)	358	384	408	434	482	497	516	545	567	615	662.43	793

## Recommended installation

### Recommended pipe lengths

The drawings below represent recommended pipe lengths for the installation of the Rosemount 3812 Liquid Ultrasonic Flow Meter. Please consult a Rosemount technical specialist for installation recommendations of specific applications. Other lengths or flow conditioners can be accommodated.

**Figure 8: Piping Recommendation for Liquid Ultrasonic Meter (No Flow Conditioner)**

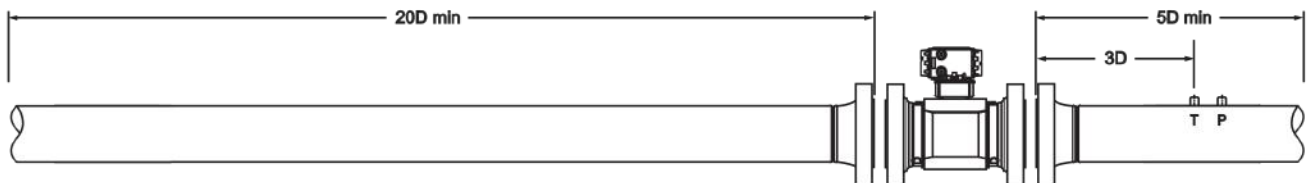

**Figure 9: Piping Recommendation for Liquid Ultrasonic Meter with a Flow Conditioner**

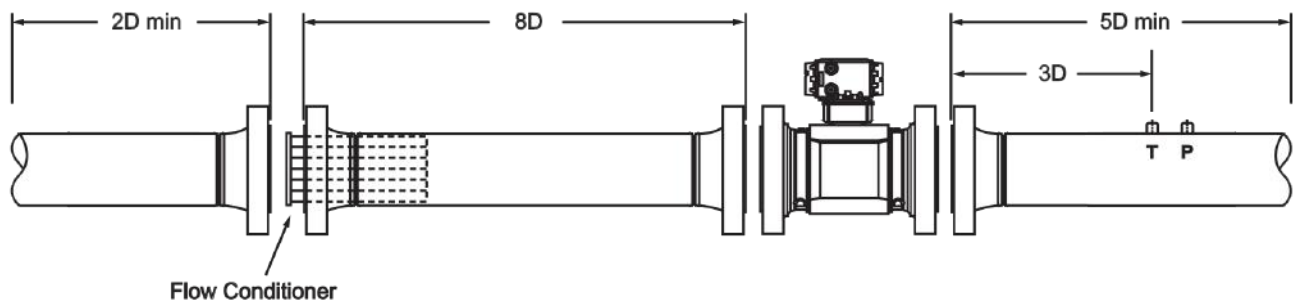
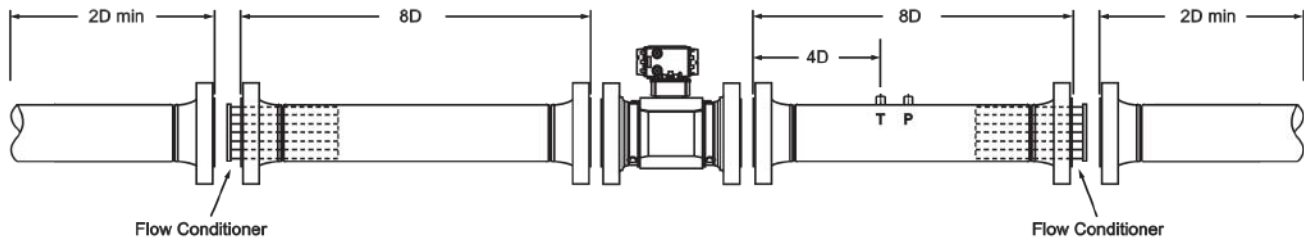

Figure 10: Piping Recommendation for Bi-directional Liquid Ultrasonic Meter with Flow Conditioners



Notes:

- For best results flow conditioning is recommended
- D = Nominal pipe size in inches (i.e. 6-in pipe size; 10D = 60-in)
- P = Pressure measurement location
- T = Temperature measurement location
- 4-in to 10-in meter body shown

## Configuration code

This is an example of a configurator code. This is for informational purposes only. Not every option is listed and some options are contingent on others. Please consult factory for assistance designing your optimal meter.

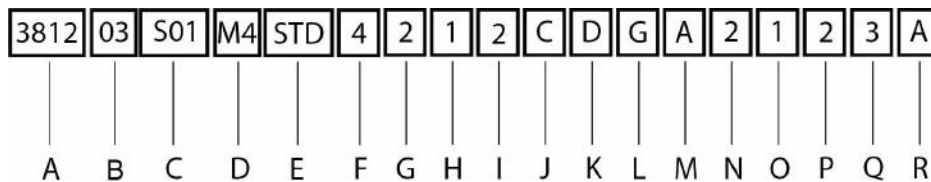

A. Line size	J. Electronics mounting
B. Pressure rating	K. CPU/Display
C. Flange type	L. Expansion module
D. Body and flange material	M. Wireless
E. Schedule (pipe bore)	N. Tagging format
F. Transducer assembly	O. Tagging language (for all tags)
G. Enclosure type/Input power	P. Pressure Directive Certification
H. Future	Q. Electrical approvals
I. Conduit type	R. Future

This is for informational purposes only. Not every option is listed and some options are contingent on others. Please consult factory for assistance designing your optimal meter.

Category	Code	Description
Device	3812	3218 Two-Path Liquid Ultrasonic Flow Meter
Line size	04	DNI 00 (4-in)
	06	DNI 50 (6-in)

	08	DN200 (8-in)
	10	DN250 (10-in)
	12	DN300 (12-in)
	14	DN350 (14-in)
	16	DN400 (16-in)
	18	DN450 (18-in)
	20	DN500 (20-in)
	24	DN600 (24-in)
	28	DN700 (28-in)
	30	DN750 (30-in)
	36	DN900 (36-in) <sup>(1)</sup>

(1) Consult factory on sizes above DN900 (36-in) and on pressure ratings greater than PN 150 (ANSI 900).

Category	Code	Description
Pressure rating	01	PN 20 / ISO ANSI
	03	PN 50 / 300 ANSI
	05	PN 100 / 600 ANSI
	06	PN 150 / 900 ANSI <sup>(1)</sup>

(1) Consult factory on sizes above DN900 (36-in) and on pressure ratings greater than PN 150 (ANSI 900).

Flange type	S01	RF / RF
	S02	RTJ / RTJ

Body and flange material	M1	ASTM A352 Gr. LCC Carbon Steel
	M2	ASTM A351 Gr. CF8M 316 SST
	M4	ASTM A995 Gr. 4A Duplex SST
	M5	ASTM A352 Gr. LCC Carbon Steel (-50° C to +150° C)
	F1	ASTM A350 Gr. LF2 Carbon Steel (-46° C to +150° C)
	F2	ASTM A 182 Gr. F316 SST
	F3	ASTM A 182 Gr. FS 1 Duplex SST
	F4	ASTM A350 Gr. LF2 Carbon Steel (-50° C to +150° C)
	F5	ASTM A 105 Carbon Steel (-29° C to +150° C)

Schedule (pipe bore)	040	Schedule 40
	080	Schedule 80
	STD	Schedule STD (30-in and 36-in only)
	XS0	Schedule XS (30-in and 36-in only)

Transducer assembly	1	LT-10 (-50° C to +135° C) with NBR O-rings 316L Housing
	2	LT-10 (-40° C to + 150° C) with FKM O-rings 316L Housing

	3	LT-10 (-50° C to +135° C) with NBR O-rings Inconel Housing
	4	LT-10 (-40° C to +150° C) with FKM O-rings Inconel Housing
	5	LT-11 (-50° C to +135° C) with NBR O-rings
	6	LT-11 (-40° C to +150° C) with FKM O-rings
	7	LT-11 (-50° C to +135°C) with NBR O-rings Inconel Housing
	8	LT-11 (-40° C to +150° C) with FKM O-rings Inconel Housing
	9	LT-16 (-50° C to +135° C) with NBR O-rings 316L Housing
	A	LT-16 (-40° C to +175° C) with FKM O-rings 316L Housing
	B	LT-16 (-50° C to +135° C) with NBR O-rings Inconel Housing
	C	LT-16 (-40° C to +175°C) with FKM O-rings Inconel Housing
	D	L T-17 (-50° C to +135° C) with NBR O-rings
	E	LT-17 (-40° C to +175° C) with FKM O-rings
	F	LT-17 (-50° C to +135° C) with NBR O-rings Inconel Housing
	G	LT-17 (-40° C to +175° C) with FKM O-rings Inconel Housing
	H	LT-12 (-50° C to +135° C) with NBR O-rings 316L Housing
	J	LT-12 (-40° C to +150° C) with FKM O-rings 316L Housing
	K	LT-12 (-50° C to +135° C) with NBR O-rings Inconel Housing
	M	LT-12 (-40° C to +150° C) with FKM O-rings Inconel Housing
	N	LT-13 (-50° C to +135° C) with NBR O-rings
	P	LT-13 (-40° C to +150° C) with FKM O-rings
	Q	LT-13 (-50° C to +135° C) with NBR O-rings Inconel Housing
	R	LT-13 (-40° C to +150° C) with FKM O-rings Inconel Housing

Category	Code	Description
Enclosure type/Input power	1	Aluminum housing, indoor/outdoor; 10.4-36 VDC
	2	Stainless steel; 10.4-36 VDC
Future	1	None
Conduit type	1	3/4-in NPT
	2	M20 reducer
Electronics mounting	A	Integral Mounted (Up to +60° C)
	C	Remote Mounted with 8-ft Armored Conduit (Up to +150° C)
CPU/Display	C	I/O Type 2 (3 Freq./Dig. Out, 2 AO), no Display
	D	I/O Type 2 (3 Freq./Dig. Out, 2 AO), with Display
	J	I/O Type 4 (6 Freq./Dig. Out, 1 AO), no Display
	K	I/O Type 4 (6 Freq./Dig. Out, 1 AO), with Display

Category	Code	Description
Expansion module	A	None
	B	One Serial RS232
	C	One Serial RS485
	D	Expansion I/O Module
Wireless	A	None
	B	THUM
Tagging format	1	Inch / ANSI / US Customary
	2	Inch / ANSI / Metric
	3	DN / PN / US Customary
	4	DN / PN / Metric
Tagging language (for all tags)	1	English
	2	French
	3	Russian
	4	Chinese
Pressure Directive Certification	1	None
	2	PED (must select electrical approval code 2)
	3	CRN (Canadian Boiler Branch)
Electrical approvals	1	UL / c-UL Approval
	2	ATEX/IECEX (Must select pressure directive cert code 2)
	3	INMETRO
Future	A	Case option





For more information: [Emerson.com](https://www.emerson.com)

©2022 Emerson. All rights reserved.

Emerson Terms and Conditions of Sale are available upon request. The Emerson logo is a trademark and service mark of Emerson Electric Co. Rosemount is a mark of one of the Emerson family of companies. All other marks are the property of their respective owners.

**ROSEMOUNT™**

