

Rosemount™ 5300 Level Transmitter

Guided Wave Radar



- Industry leading measurement capability and reliability
- Safety certified to IEC 61508 for SIL2 applications
- Increased plant availability with predictive maintenance and easy troubleshooting
- Reduced instrument count and process penetrations with a multivariable transmitter

Taking guided wave radar benefits to the next level

Measurement principle

Low power, nano-second microwave pulses are guided down a probe submerged in the process media. When a microwave pulse reaches a medium with a different dielectric constant, part of the energy is reflected back to the transmitter.

The transmitter uses the residual wave of the first reflection for measuring the interface level. Part of the wave, which was not reflected at the upper product surface, continues until it is reflected at the lower product surface. The speed of this wave depends fully on the dielectric constant of the upper product.

The time difference between the transmitted and the reflected pulse is converted into a distance, and the total level or interface level is then calculated. The reflection intensity depends on the dielectric constant of the product: the higher dielectric constant value, the stronger reflection.

Figure 1: Measurement Principle

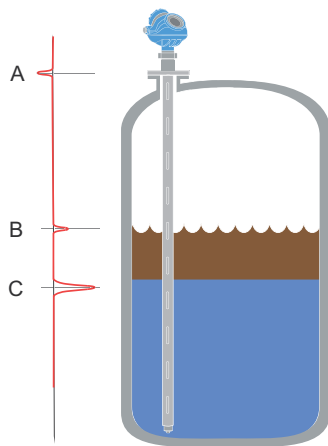

- A. Reference pulse
- B. Level
- C. Interface level

Contents

Taking guided wave radar benefits to the next level.....	2
Ordering information.....	5
Specifications.....	34
Installation and mounting considerations.....	66
Product certifications.....	74
Dimensional drawings.....	75

Guided wave radar technology benefits

- Highly accurate and reliable direct level measurement with no compensation needed for changing process conditions (such as density, conductivity, viscosity, pH, temperature, and pressure)
- No moving parts and no re-calibration result in minimized maintenance
- Handles vapor, dust, turbulence, and foam well
- Suitable for small tanks, difficult tank geometry, internal obstacles, and unaffected by the mechanical design of chambers
- Top down installation minimizes risk for leakages

Special Rosemount 5300 features

Optimized to suit more applications

- Suitable for most liquid and solids level applications and liquid interface applications
- Handles even the most challenging applications reliably, including process vessels, control, and safety systems
- Easy retrofit in existing chambers or available as complete assembly with high quality Rosemount chambers
- Dynamic Vapor Compensation assures accuracy also in saturated steam
- Large coaxial probe optimized for interface applications where there is a need to measure level and interface level all the way up to flange

Best performance and uptime

- Unique Direct Switch Technology and Probe End Projection improve capability and reliability particularly in challenging applications
- Single lead probe for long measuring ranges, obstructions and low dielectrics ensures reliability in more applications, such as viscous media
- Signal processing algorithm makes it possible to distinguish between two liquids with a top layer down to 1 in. (2.5 cm).
- Smart Galvanic Interface results in a more stable microwave and EMI performance with minimized effects from outside disturbances

Robust design and increased safety

- Heavy-duty unique hardware for extreme temperature and pressures with multiple layers of protection
- EchoLogics[®] and smart software functions provide enhanced ability to keep track of the surface and detect a full vessel situation
- Third party approved for overfill prevention and Safety Integrated System SIL3 suitability
- Electronics and cable connections in separate compartments provides safer handling and improved moisture protection
- Online device verification and reliable detection of high level conditions with the verification reflector

Easy installation and plant integration

- Easy upgrade by matching existing tank connections and cut-to-fit probes
- Long lengths of rigid probes for robust measurements become cost-effective and practical to ship, store and install with the segmented probe option (code 4S)
- Multivariable device reduces the number of process penetrations
- Seamless system integration with HART[®], FOUNDATION[™] Fieldbus, Modbus[®], or IEC 62591 (*WirelessHART[®]*) with the Emerson Wireless 775 THUM[™] Adapter
- Pre-configured or easy configuration in Rosemount Radar Master with a five-step wizard, auto connect, and online help
- Enhanced DD with step-by-step configuration and echo curve capability in tools such as AMS Device Manager, and handheld communicator

- DTM™ with echo curve capability for use in FDT®/DTM compatible configuration tools such as PACTware™, Yokogawa FieldMate/PRM

Minimized maintenance reduces cost

- Easy online troubleshooting with user friendly software, utilizing powerful echo curve and logging tools
- Signal Quality Metrics diagnostics detect product build-up on probe to monitor turbulence, boiling, foam, and emulsions
- Predictive maintenance with advanced diagnostics and Plantweb™ alerts
- Modular design for reduced spare parts and easy replacement of the transmitter housing without opening the tank

Access information when you need it with asset tags

Newly shipped devices include a unique QR code asset tag that enables you to access serialized information directly from the device. With this capability, you can:

- Access device drawings, diagrams, technical documentation, and troubleshooting information in your MyEmerson account
- Improve mean time to repair and maintain efficiency
- Ensure confidence that you have located the correct device
- Eliminate the time-consuming process of locating and transcribing nameplates to view asset information

Ordering information

Online product configurator

Many products are configurable online using our Product Configurator. Select the **Configure** button or visit our [website](#) to start. With this tool's built-in logic and continuous validation, you can configure your products more quickly and accurately.

Specifications and options

See the Specifications and options section for more details on each configuration. Specification and selection of product materials, options, or components must be made by the purchaser of the equipment. See the Material selection section for more information.

Model codes

Model codes contain the details related to each product. Exact model codes will vary; an example of a typical model code is shown in [Figure 2](#).

Figure 2: Model Code Example

<u>5301 HA 1 S 1 V 1A M 002 05 AA 11</u>	<u>M1 C1 WR5</u>
1	2

1. Required model components (choices available on most)
2. Additional options (variety of features and functions that may be added to products)

Optimizing lead time

The starred offerings (★) represent the most common options and should be selected for the fastest delivery times. The non-starred offerings are subject to additional delivery lead time.

Rosemount 5301 and 5302 Level and/or Interface in Liquids



Rosemount 5301 and 5302 Guided Wave Radar Level Transmitters provide industry leading measurement capabilities and reliability in liquids. Characteristics include:

- Direct Switch Technology and Probe End Projection to handle low reflective media and long measuring ranges
- Wide range of probe styles, materials, and temperatures and pressures for application flexibility
- HART 4-20 mA, FOUNDATION™ Fieldbus, Modbus, or IEC 62591 (*WirelessHART*®) with the THUM Adapter (see [Emerson Wireless 775 THUM™ Adapter](#) for details)
- Safety-certified to IEC 61508 (option code QT)
- Advanced diagnostics (option code D01 or DA1)
- Transmitter verification and high level supervision (option code HL1, HL2, or HL3)

Specification and selection of product materials, options, or components must be made by the purchaser of the equipment. See [Material selection](#) for more information on material selection.

CONFIGURE >

VIEW PRODUCT >

Required model components

Model

Code	Description	
5301	Guided Wave Radar Liquid Level or Interface Transmitter (interface available for fully submerged probe)	★
5302	Guided Wave Radar Liquid Level and Interface Transmitter	★

Signal output

Code	Description	
H	4-20 mA with HART communication (default output from factory is HART 7, add option code HR5 for HART 5)	★
F	FOUNDATION Fieldbus	★
M	RS-485 with Modbus communication	★
U	Rosemount 2410 Tank Hub connectivity	

Related information

- [4-20 mA HART](#)
- [FOUNDATION Fieldbus](#)
- [Modbus](#)

Housing material

Code	Description	
A	Polyurethane-covered Aluminum (Aluminum alloy A360, maximum 0.6 percent Cu)	★
S	Stainless Steel, Grade CF8M (ASTM A743)	

Conduit / cable threads

Code	Description		
1	½ - 14 NPT	1 plug included	★
2	M20 x 1.5 adapter	1 adapter and 1 plug included	★
4	2 pcs M20 x 1.5 adapter	2 adapters and 1 plug included	★
G ⁽¹⁾⁽²⁾	Metal cable gland (½ - 14 NPT)	2 glands and 1 plug included	★
E ⁽³⁾	M12, 4-pin, male connector (eurofast®)	1 plug included	★
M ⁽³⁾	A size Mini, 4-pin, male connector (minifast®)	1 plug included	★

- (1) Not available with explosion-proof or flameproof approvals.
- (2) Minimum temperature is -20 °C (-4 °F).
- (3) Not available with explosion-proof, flameproof, or increased safety approvals.

Operating temperature and pressure

Process seal rating. Final rating depends on Material of construction, Flange, and O-ring selection.

Code	Description	Probe type	
Standard (Std)			
S	Design and operating temperature: -40 to 302 °F (-40 to 150 °C)	Design and operating pressure: -15 to 754 psig (-1 to 52 bar) ⁽¹⁾	1A, 2A, 3A, 3B, 3C, 4A, 4B, 4S, 5A, and 5B ★
High Pressure (HP)			
p ⁽²⁾	Design temperature: -76 to 752 °F (-60 to 400 °C) ⁽³⁾ Operating temperature: -76 to 500 °F (-60 to 260 °C) ⁽⁴⁾	Design and operating pressure: -15 to 5000 psig (-1 to 345 bar)	3A, 3B, 3C, 4A, 4B, 4S, 5A, and 5B ★
High Temperature / High Pressure (HTHP)			
H ⁽²⁾⁽⁵⁾	Design and operating temperature: -76 to 752 °F (-60 to 400 °C)	Design and operating pressure: -15 to 5000 psig (-1 to 345 bar)	3A, 3B, 3V, 4A, 4B, 4S, 4U, 5A, and 5B ★
Cryogenic Temperature (C)			
C ⁽²⁾	Design and operating temperature: -320 to 392 °F (-196 to 200 °C)	Design and operating pressure: -15 to 5000 psig (-1 to 345 bar)	3A, 3B, 3C, 4A, 4B, 4S, 5A, 5B (Only SST)

- (1) Maximum pressure is 580 psig (40 bar) for O-ring material code B (Nitrile Butadiene), Country certification code J7, Overfill prevention code U1, and Material of construction code 2 or 3.
- (2) Requires option None for sealing (no O-ring).
- (3) Pressure retaining parts are designed for up to 752 °F (400 °C), maximum operating temperature is 500 °F (260 °C).
- (4) Maximum operating temperature is 482 °F (250 °C) for option code U1.
- (5) For applications where operating temperature cycles exclusively below 500 °F / 260 °C, and other applications where a large amount of contamination is present, the High Pressure (HP) or Standard (Std) seal should be used, if process conditions allow.

Related information

[Process temperature and pressure rating](#)

[Flange rating](#)

[Plate design](#)

[Tri Clamp rating](#)

Material of construction: Process connection / probe

For other materials, consult the factory.

Code	Description	Probe type	Valid operation temperature and pressure	
1	316/316L/EN 1.4404	All	S, H, P, C	★
2	Alloy C-276 (UNS N10276). With plate design if flanged version. Up to class 600/PN 63 for HTHP/HP probes.	3A, 3B, 4A, 4B, 5A, 5B	S, H, P	
3	Alloy 400 (UNS N04400). With plate design if flanged version.	3A, 3B, 4A, 4B, 5A, 5B	S	
7	PTFE covered probe and flange. With plate design.	4A and 5A	S	
8	PTFE covered probe	4A and 5A	S	
H	Alloy C-276 (UNS N10276) process connection, flange, and probe	3A, 3B, 4A, 4B, 5A, 5B	S, H, P	
D	Duplex 2205 (EN 1.4462/UNS S31803) process connection, flange, and probe	4B, 5A, 5B	S, H, P	
E	Alloy 825 (UNS N08825) process connection, flange, and probe	4B, 5A, 5B	S, H, P	

Sealing O-ring material

For other materials, consult the factory.

Code	Description	
N ⁽¹⁾	None	★
V	Fluoroelastomer (FKM)	★
E	Ethylene Propylene (EPDM)	★
K	Kalrez [®] Perfluoroelastomer (FFKM)	★
B	Nitrile Butadiene (NBR)	★
F	Fluorsilicone (FVMQ)	★

(1) Requires Operating Temperature and Pressure code H, P, or C.

Probe type

Code	Description	Process connections	Probe lengths	
3B	Coaxial, perforated. For level and interface measurement.	Flange / 1-in. ⁽¹⁾ , 1½-in., 2-in. ⁽¹⁾ Thread	Min: 1 ft. 4 in. (0.4 m) Max: 19 ft. 8 in. (6 m)	★
3C ⁽²⁾	Large coaxial, perforated. For level and interface measurement.	Flange / 1½-in., 2-in. ⁽¹⁾ Thread	Min: 1 ft. (0.3 m) Max: 19 ft. 8 in. (6 m)	★
3V ⁽³⁾ (4)(5)	Integrated Still Pipe Vapor Probe. For 3-in. chambers and above. Refer to "Options" to specify reference reflector length.	Flange	Min: 2 ft. 11 in. (0.9 m) for the short reflector (R1 option) Min: 3 ft. 7 in. (1.1 m) for the long reflector (R2 option) Max: 13 ft. 1 in. (4 m)	★
4A	Rigid Single Lead (8 mm)	Flange / 1-in. ⁽¹⁾ , 1½-in., 2-in. ⁽¹⁾ Thread / Tri Clamp	Min: 1 ft. 4 in. (0.4 m) Max: 9 ft. 10 in. (3 m)	★
4B	Rigid Single Lead (13mm)	Flange / 1-in., 1½-in., 2-in. Thread / Tri Clamp	Min: 1 ft. 4 in. (0.4 m) Max: 19 ft. 8 in. (6 m)	★
4U ⁽³⁾ (4)(5)	Single Rigid Vapor Probe (equip with a 1½-in. centering disc). For 2-in. chambers. Refer to "Options" to specify reference reflector length.	Flange / 1½-in. Thread	Min: 2 ft. 11 in. (0.9 m) for the short reflector (R1 option) Min: 3 ft. 7 in. (1.1 m) for the long reflector (R2 option) Max: 9 ft. 10 in. (3 m)	★
5A ⁽⁶⁾	Flexible Single Lead with weight	Flange / 1-in. ⁽¹⁾ , 1½-in., 2-in. ⁽¹⁾ Thread / Tri Clamp	Min: 3 ft. 4 in. (1 m) Max: 164 ft. (50 m) ⁽⁷⁾	★
5B ⁽⁸⁾	Flexible Single Lead with chuck	Flange / 1-in. ⁽¹⁾ , 1½-in., 2-in. ⁽¹⁾ Thread / Tri Clamp	Min: 3 ft. 4 in. (1 m) Max: 164 ft. (50 m) ⁽⁷⁾	★
1A ⁽¹⁾	Rigid Twin Lead	Flange / 1½-in., 2-in. ⁽¹⁾ Thread	Min: 1 ft. 4 in. (0.4 m) Max: 9 ft. 10 in. (3 m)	
2A ⁽¹⁾	Flexible Twin Lead with weight	Flange / 1½-in., 2-in. ⁽¹⁾ Thread	Min: 3 ft. 4 in. (1 m) Max: 164 ft. (50 m)	
3A ⁽⁹⁾	Coaxial (for level measurement)	Flange / 1-in. ⁽¹⁾ , 1½-in., 2-in. ⁽¹⁾ Thread	Min: 1 ft. 4 in. (0.4 m) Max: 19 ft. 8 in. (6 m)	
4S	Segmented Rigid Single Lead (13mm)	Flange / 1-in., 1½-in., 2-in. Thread / Tri Clamp	Min: 1 ft. 4 in. (0.4 m) Max: 32 ft. 9 in. (10 m)	

- (1) Only available with Operating Temperature and Pressure code S.
- (2) Requires firmware version 2.L3 or later.
- (3) Only available with Operating Temperature and Pressure code H.
- (4) Not available with Remote housing code B1 or B2.
- (5) Probe type 3V or 4U together with flanges Class 2500/PN250 or higher requires installation option code HS (Heat sink).
- (6) 0.79 lb (0.36 kg) standard weight for flexible single lead probe. L=5.5 in. (140 mm). For PTFE covered probes: 2.2 lb (1 kg) standard weight for flexible single lead probe. L=17.1 in. (434 mm).
- (7) Maximum probe length for Duplex 2205 probes is 105 ft (32 m).
- (8) Extra length for fastening is added in factory.
- (9) Requires model 5301.

Probe length units

Code	Description	
E	English (feet, inches)	★
M	Metric (meters, centimeters)	★

Total probe length (feet/m)

Probe weight included if applicable. Give the total probe length in feet and inches or meters and centimeters, depending on selected probe length unit. If tank height is unknown, please round up to an even length when ordering. Probes can be cut to exact length in field. Maximum allowable length is determined by process conditions.

Code	Description	
XXX	0-164 ft. or 0-50 m	★

Related information

[Total probe length](#)

Total probe length (inch/cm)

Probe weight included if applicable. Give the total probe length in feet and inches or meters and centimeters, depending on selected probe length unit. If tank height is unknown, please round up to an even length when ordering. Probes can be cut to exact length in field. Maximum allowable length is determined by process conditions.

Code	Description	
XX	0 - 11 in. or 0-99 cm	★

Related information

[Total probe length](#)

Process connection - size / type

For other process connections, consult the factory.

Code	Description	
ASME flanges ⁽¹⁾		
	Material of construction	Operating temperature and pressure
AA	2-in. Class 150, RF (Raised Face Type)	1, 2, 3, 7, 8, H, D, E
AB	2-in. Class 300, RF (Raised Face Type)	1, 2, 3, 7, 8, H, D, E
AC	2-in. Class 600, RF (Raised Face Type)	1, 2, H, D, E
AD	2-in. Class 900, RF (Raised Face Type)	1, H, D, E
BA	3-in. Class 150, RF (Raised Face Type)	1, 2, 3, 7, 8, H, D, E
BB	3-in. Class 300, RF (Raised Face Type)	1, 2, 3, 7, 8, H, D, E
BC	3-in. Class 600, RF (Raised Face Type)	1, 2, H, D, E
BD	3-in. Class 900, RF (Raised Face Type)	1, H, D, E
CA	4-in. Class 150, RF (Raised Face Type)	1, 2, 3, 7, 8, H, D, E
CB	4-in. Class 300, RF (Raised Face Type)	1, 2, 3, 7, 8, H, D, E
CC	4-in. Class 600, RF (Raised Face Type)	1, 2, H, D, E

Code	Description			
CD	4-in. Class 900, RF (Raised Face Type)	1, H, D, E	H, P, C	★
AE	2-in. Class 1500, RF (Raised Face Type)	1, H, D, E	H, P, C	
AF	2-in. Class 2500, RF (Raised Face Type)	1	H, P, C	
AI	2-in. Class 600, RTJ (Ring Type Joint)	1, H, D, E	H, P, C	
AJ	2-in. Class 900, RTJ (Ring Type Joint)	1, H, D, E	H, P, C	
AK	2-in. Class 1500, RTJ (Ring Type Joint)	1, H, D, E	H, P, C	
BE	3-in. Class 1500, RF (Raised Face Type)	1, H, D, E	H, P, C	
BF	3-in. Class 2500, RF (Raised Face Type)	1	H, P, C	
BI	3-in. Class 600, RTJ (Ring Type Joint)	1, H, D, E	H, P, C	
BJ	3-in. Class 900, RTJ (Ring Type Joint)	1, H, D, E	H, P, C	
BK	3-in. Class 1500, RTJ (Ring Type Joint)	1, H, D, E	H, P, C	
CE	4-in. Class 1500, RF (Raised Face Type)	1, H, D, E	H, P, C	
CI	4-in. Class 600, RTJ (Ring Type Joint)	1, H, D, E	H, P, C	
CJ	4-in. Class 900, RTJ (Ring Type Joint)	1, H, D, E	H, P, C	
CK	4-in. Class 1500, RTJ (Ring Type Joint)	1, H, D, E	H, P, C	
DA	6-in. Class 150, RF (Raised Face Type)	1, 2, 3, 7, 8, H	S, H, P, C	
DB	6-in. Class 300, RF (Raised Face Type)	1, 2, 3, 7, 8, H	S, H, P, C	
EN 1092-1 flanges		Material of construction	Operating temperature and pressure	
HB	DN50, PN40, Type A flat face	1, 2, 3, 7, 8	S, H, P, C	★
HC	DN50, PN63, Type A flat face	1, 2, 3	H, P, C	★
HD	DN50, PN100, Type A flat face	1	H, P, C	★
IA	DN80, PN16, Type A flat face	1, 2, 3, 7, 8	S, H, P, C	★
IB	DN80, PN40, Type A flat face	1, 2, 3, 7, 8	S, H, P, C	★
IC	DN80, PN63, Type A flat face	1, 2, 3	H, P, C	★
ID	DN80, PN100, Type A flat face	1	H, P, C	★
JA	DN100, PN16, Type A flat face	1, 2, 3, 7, 8	S, H, P, C	★
JB	DN100, PN40, Type A flat face	1, 2, 3, 7, 8	S, H, P, C	★
JC	DN100, PN63, Type A flat face	1, 2, 3	H, P, C	★
HI	DN50, PN40, Type E spigot face	1, 8	S, H, P, C	
HP	DN50, PN16, Type C tongue face	1, 8	S, H, P, C	
HQ	DN50, PN40, Type C tongue face	1, 8	S, H, P, C	
IE	DN80, PN160, Type B2 raised face	1	H, P, C	
IH	DN80, PN16, Type E spigot face	1, 8	S, H, P, C	
II	DN80, PN40, Type E spigot face	1, 8	S, H, P, C	
JE	DN100, PN160, Type B2 raised face	1	H, P, C	

Code	Description			
JH	DN100, PN16, Type E spigot face	1, 8	S, H, P, C	
JI	DN100, PN40, Type E spigot face	1, 8	S, H, P, C	
JQ	DN100, PN40, Type C tongue face	1, 8	S, H, P, C	
KA	DN150, PN16, Type A flat face	1, 2, 3, 7, 8	S, H, P, C	
KB	DN150, PN40, Type A flat face	1, 2, 3, 7, 8	S, H, P, C	
KH	DN150, PN16, Type E spigot face	1, 8	S, H, P, C	
NI	DN65, PN40, Type E spigot face	1, 8	S, H, P, C	
JIS flanges		Material of construction	Operating temperature and pressure	
UA	50A, 10K, RF (Raised Face Type)	1, 2, 3, 7, 8	S, H, P, C	★
VA	80A, 10K, RF (Raised Face Type)	1, 2, 3, 7, 8	S, H, P, C	★
XA	100A, 10K, RF (Raised Face Type)	1, 2, 3, 7, 8	S, H, P, C	★
Threaded connections		Material of construction	Probe type	
RA	1½-in. NPT thread	1, 2, 3, 8, H, D	1A, 2A, 3A, 3B, 3C, 4A, 4B, 4S, 4U, 5A, 5B	★
RC	2-in. NPT thread	1, 8	1A, 2A, 3A, 3B, 3C, 4A, 4B, 4S, 5A, 5B, standard temperature and pressure	★
RB	1-in. NPT thread	1, 8	3A, 3B, 4A, 4B, 4S, 5A, 5B, standard temperature and pressure	
SA	1½-in. BSP (G 1½-in.) thread	1, 2, 3, 8, H, D	1A, 2A, 3A, 3B, 3C, 4A, 4B, 4S, 4U, 5A, 5B	
SB	1-in. BSP (G 1-in.) thread	1, 8	3A, 3B, 4A, 4B, 4S, 5A, 5B, standard temperature and pressure	
Tri Clamp fittings ⁽²⁾		Material of construction	Probe type	
FT	1½-in. Tri Clamp	1, 7, 8	4A, 5A, 5B standard temperature and pressure	
AT	2-in. Tri Clamp	1, 7, 8	4A, 4B, 5A, 5B, 4S standard temperature and pressure	
BT	3-in. Tri Clamp	1, 7, 8	4A, 4B, 5A, 5B, 4S standard temperature and pressure	
CT	4-in. Tri Clamp	1, 7, 8	4A, 4B, 5A, 5B, 4S standard temperature and pressure	

Code	Description			
	Proprietary flanges	Material of construction	Operating temperature and pressure	
TF	Fisher - proprietary 316/316L (for 249B, 259B chambers) Torque Tube Flange	1, 7, 8	S, H, P, C	★
TT	Fisher - proprietary 316/316L (for 249C chambers) Torque Tube Flange	1, 7, 8	S, H, P, C	★
TM	Masoneilan - proprietary 316/316L Torque Tube Flange	1, 7, 8	S, H, P, C	★

(1) Design according to ASME B31.3. No code stamp or ASME certificate available.

(2) Follows ISO 2852 standard.

Hazardous locations certifications

Code	Description	
NA	No Hazardous Locations Certifications	★
E1 ⁽¹⁾	ATEX/UKEX Flameproof	★
E3 ⁽¹⁾	China Flameproof	★
E5 ⁽¹⁾	USA Explosion-proof	★
E6 ⁽¹⁾	Canadian Explosion-proof	★
E7 ⁽¹⁾	IECEx Flameproof	★
I1	ATEX/UKEX Intrinsic Safety	★
IA ⁽²⁾	ATEX/UKEX FISCO Intrinsic Safety	★
I3	China Intrinsic Safety	★
IC ⁽²⁾	China FISCO Intrinsic Safety	★
I5	USA Intrinsic Safety and Non-Incendive	★
IE ⁽²⁾	USA FISCO Intrinsic Safety	★
I6	Canadian Intrinsic Safety	★
IF ⁽²⁾	Canadian FISCO Intrinsic Safety	★
I7	IECEx Intrinsic Safety	★
IG ⁽²⁾	IECEx FISCO Intrinsic Safety	★
E2 ⁽¹⁾	INMETRO Flameproof	
EM ⁽¹⁾	Technical Regulations Customs Union (EAC) Flameproof	
I2	INMETRO Intrinsic Safety	
IB ⁽²⁾	INMETRO FISCO Intrinsic Safety	
IM	Technical Regulations Customs Union (EAC) Intrinsic Safety	
IN ⁽²⁾	Technical Regulations Customs Union (EAC) FISCO Intrinsic Safety	
EW	India PESO Flameproof	
IW	India PESO Intrinsic Safety	
E4 ⁽¹⁾	Japan Flameproof	

Code	Description	
EP ⁽¹⁾⁽³⁾	Republic of Korea Flameproof	
KA ⁽¹⁾	ATEX/UKEX, USA, Canadian Flameproof/Explosion-proof	
KB ⁽¹⁾	ATEX/UKEX, USA, IECEx Flameproof/Explosion-proof	
KC ⁽¹⁾	ATEX/UKEX, Canadian, IECEx Flameproof/Explosion-proof	
KD ⁽¹⁾	USA, Canadian, IECEx Flameproof/Explosion-proof	
KE	ATEX/UKEX, USA, Canadian Intrinsic Safety	
KF	ATEX/UKEX, USA, IECEx Intrinsic Safety	
KG	ATEX/UKEX, Canadian, IECEx Intrinsic Safety	
KH	USA, Canadian, IECEx Intrinsic Safety	
KI ⁽²⁾	FISCO - ATEX/UKEX, USA, Canadian Intrinsic Safety	
KJ ⁽²⁾	FISCO - ATEX/UKEX, USA, IECEx Intrinsic Safety	
KK ⁽²⁾	FISCO - ATEX/UKEX, Canadian, IECEx Intrinsic Safety	
KL ⁽²⁾	FISCO - USA, Canadian, IECEx Intrinsic Safety	
N1	ATEX/UKEX Increased Safety	
N7	IECEx Increased Safety	

(1) Probes are intrinsically safe.

(2) Requires FOUNDATION Fieldbus signal output (U_i parameter listed in Product Certifications).

(3) The EP (Republic of Korea Flameproof) certificate is based on the E7 (IECEx Flameproof) certificate, therefore model code E7 is stated in the certificate instead of EP.

Related information

[Product certifications](#)

Additional options

Display

Code	Description	
M1	Integral digital display	★

Communication

Code	Description	
HR5	4–20 mA with digital signal based on HART 5 protocol	★
HR7	4–20 mA with digital signal based on HART 7 protocol	★

Hydrostatic testing

Available for tank connection with flange.

Code	Description	
P1	Hydrostatic testing, including certificate	★

Factory configuration

Code	Description	
C1	Factory configuration per Configuration Data Sheet	★

Alarm limits

Code	Description	
C4	NAMUR alarm and saturation levels, high alarm	★
C5	NAMUR alarm and saturation levels, low alarm	★
C8 ⁽¹⁾	Standard Rosemount alarm and saturation levels, low alarm	★

(1) The standard alarm setting is high.

Welding procedure qualification record documentation

Weldings in accordance with EN/ISO standards.

Code	Description	
Q66	Welding Procedure Qualification Record (WPQR)	★
Q67	Welder Performance Qualification (WPQ)	★
Q68	Welding Procedure Specification (WPS)	★

Special quality assurance

Code	Description	
Q4	Calibration data certificate	★
QG	Calibration certificate and GOST verification certificate (only for end-destination country Russia)	

Material traceability certification

Certificate includes all pressure retaining wetted parts.

Code	Description	
Q8	Material traceability certification consistent with ISO10474-3.1:2013 / EN10204-3.1:2004	★

Safety certifications

Code	Description	
QS	Prior-use certificate of FMEDA Data. Only available with HART 4-20 mA output (output code H).	★
QT	Safety-certified to IEC 61508 with certificate of FMEDA data. Only available with HART 4-20 mA output (output code H).	★

Country certification

Code	Description	
J1	Canadian Registration Number (CRN)	★
J2 ⁽¹⁾	ASME B31.1	★
J7 ⁽²⁾	Indian Boiler Regulation (For witnessed Form III-C from factory, order certificate Q47 on separate line item)	
J8 ⁽³⁾⁽⁴⁾	EN Boiler (European Boiler Approval in accordance with EN 12952-11 and EN 12953-9)	★

- (1) Design and manufacturing according to ASME B31.1. No code stamp or ASME certificate available. Welding in accordance with ASME IX.
- (2) Only available with Material of construction code 1, Operating temperature and pressure code S, H, or P, Probe type 3A, 3B, 3V, 4U, 4A, 4B, 4S, 5A, or 5B, together with ASME flanges size 2-in, 3-in, or 4-in.
- (3) Only available with Signal output code H and Probe type code 3V or 4U.
- (4) Suitable for use as a level sensor part of a limiting device, in accordance with EN 12952-11 and EN 12953-9.

Dye penetration test certificate

Code	Description	
Q73	Certificate of liquid penetrant inspection	★

Positive material identification certificate

Code	Description	
Q76	Positive material identification certificate of conformance	★

Materials certification

Available for probe type 3A, 3B, 3C, 4A, 4B, 4S, and PTFE-coated 5A.

Code	Description	
N2	NACE® material recommendation per NACE MR0175/ISO 15156 and NACE MR0103/ISO 17945	★

Marine / shipboard approvals

Transmitters with aluminum housing are not approved for open deck installations.

Code	Description	
SBS	American Bureau of Shipping Type Approval	★
SDN	Det Norske Veritas Germanischer Lloyd (DNV GL) Type Approval	★
SLL	Lloyd's Register Type Approval	★
SKR	Korean Register Type Approval	★
SBV	Bureau Veritas Type Approval	★
SNK	Nippon Kaiji Kyokai Type Approval	★
SRS	Russian Maritime Register of Shipping	★

Installation options

Code	Description	
LS ⁽¹⁾	Long stud 9.8 in (250 mm) for flexible single lead probe to prevent contact with wall/nozzle. Standard stud length is 3.9 in (100 mm) for probes 5A and 5B.	★
BR	316L Mounting Bracket for 1½-in. NPT Process Connection (RA)	
HS ⁽²⁾	Heat sink	

(1) Not available with PTFE covered probes.

(2) Requires Remote housing code B3, and Probe type code 3V or 4U.

Related information

[Dimensional drawings](#)

Weight and anchoring options for flexible single probes

Code	Description	
W3	Heavy Weight (for most applications)	★
W2	Short Weight (when measuring close to the probe end)	

Related information

[Dimensional drawings](#)

Weight assembly options for flexible single probes

Code	Description	
WU	Weight or chuck not mounted on the probe	★

Transient protection

Code	Description	
T1	Transient Protection Terminal Block. Selectable with HART 4-20 mA output (output code H). Already included in all FOUNDATION Fieldbus variations.	★

Diagnostic functionality

Code	Description	
D01	FOUNDATION Fieldbus Diagnostics Suite (includes Signal Quality Metrics diagnostics ⁽¹⁾)	★
DA1	HART Diagnostics Suite (includes Signal Quality Metrics diagnostics ⁽¹⁾)	★

(1) Signal Quality Metrics diagnostics is not compatible with interface measurement where the probe is fully submerged.

Related information

[Diagnostics Suite](#)

Cold temperature

Code	Description	
BR5 ⁽¹⁾⁽²⁾ (3)(4)	-67 °F (-55 °C) cold temperature	

- (1) Only available for end-destination countries within the EAC Economic Union (Russia, Belarus, Kazakhstan, Armenia, and Kyrgyzstan).
- (2) Consider any temperature limitations dependent on Material of construction, Hazardous locations certifications, and/or O-ring selection.
- (3) Not available with option code QS or U1.
- (4) For ambient temperatures between -67 °F (-55 °C) and -40 °F (-40 °C), the ambient temperature effect is ± 0.012 in. (0.3 mm) /°K or ± 45 ppm/°K of measured value, whichever is greatest. Other performance specifications apply to ambient temperatures between -40 °F (-40 °C) and 185 °F (85 °C).

Verification reflectors (high level supervision)

Only available with HART 4-20 mA output (code H), standard operating temperature and pressure (code S), material of construction (code 1), and flexible single lead probes (probe type 5A or 5B).

Code	Description	
HL1	Verification reflector for 3- to 6-in. pipe/chamber (High Level Supervision).	
HL2	Verification reflector for 8-in. pipe/chamber (High Level Supervision).	
HL3	Verification reflector for tanks and 10-in. or wider pipe/chamber (High Level Supervision).	

Related information

[Verification reflector](#)

Overfill prevention

Code	Description	
U1	Overfill prevention according to WHG/TUV	★

Extended product warranty

Rosemount extended warranties have a limited warranty of three or five years from date of shipment.

Code	Description	
WR3	3-year limited warranty	★
WR5	5-year limited warranty	★

Centering discs

Code	Description	Outer diameter	
S2 ⁽¹⁾	2-in. Centering disc	1.8 in. (45 mm)	★
S3 ⁽¹⁾	3-in. Centering disc	2.7 in. (68 mm)	★
S4 ⁽¹⁾	4-in. Centering disc	3.6 in. (92 mm)	★
P2 ⁽²⁾	2-in. Centering disc PTFE	1.8 in. (45 mm)	★
P3 ⁽²⁾	3-in. Centering disc PTFE	2.7 in. (68 mm)	★
P4 ⁽²⁾	4-in. Centering disc PTFE	3.6 in. (92 mm)	★
S6 ⁽¹⁾	6-in. Centering disc	5.55 in. (141 mm)	

Code	Description	Outer diameter
S8 ⁽¹⁾	8-in. Centering disc	7.40 in. (188 mm)
P6 ⁽²⁾	6-in. Centering disc PTFE	5.55 in. (141 mm)
P8 ⁽²⁾	8-in. Centering disc PTFE	7.40 in. (188 mm)

(1) Available for SST, Alloy C-276, Alloy 400, Alloy 825, and Duplex 2205 probes, type 2A, 4A, 4B, 4S, and 5A. Same disc material as probe material.

(2) Available for probe types 2A, 4A, 4B, 4S, and 5A. Not available with Operating Temperature and Pressure code H or Material of Construction codes 7 and 8.

Related information

[Centering disc for pipe installations](#)

Remote housing

Not available with Marine/shipboard approvals.

Code	Description
B1	1 m/3.2 ft. Remote housing mounting cable and 316L bracket
B2	2 m/6.5 ft. Remote housing mounting cable and 316L bracket
B3	3 m/9.8 ft. Remote housing mounting cable and 316L bracket

Related information

[Dimensional drawings](#)

Reference reflectors for dynamic vapor compensation probes

Required for probe type 3V and 4U.

Code	Description
R1	Short reflector. Length=14 in. (350 mm)
R2	Long reflector. Length=20 in. (500 mm)

Related information

[Select reference reflector](#)

Assemble/consolidate to chamber

Selecting the XC option code on the Rosemount 5300 and a Rosemount chamber will result in matching, consolidating, configuring, and shipping of the two products in one crate. Note that the flange bolts are only hand-tightened. Long rigid single lead probes (>8 ft./2.5 m) are ship separately in order to reduce transportation risk damage.

Code	Description
XC	Consolidate to Chamber

★

Related information

[Rosemount chamber](#)

Specials

Code	Description
RXXXX	Custom engineered solutions beyond standard model codes. Consult factory for details.

Related information

[Engineered solutions](#)

Rosemount 5303 Level for Solids



Rosemount 5303 Guided Wave Radar Level Transmitter provides industry leading measurement capabilities and reliability on solids. Characteristics include:

- Direct Switch Technology and Probe End Projection to handle low reflective media and long measuring ranges
- Measurement independent of dust, moisture and material fluctuations
- HART 4-20 mA, FOUNDATION™ Fieldbus, Modbus, or IEC 62591 (*WirelessHART*®) with the THUM Adapter (see [Emerson Wireless 775 THUM™ Adapter](#) for details)
- Probes for high physical weight loads (probe type 6A and 6B)
- Long stud available to prevent contact with nozzle (LS option)

Specification and selection of product materials, options, or components must be made by the purchaser of the equipment. See [Material selection](#) for more information on material selection.

CONFIGURE >

VIEW PRODUCT >

Required model components

Model

Code	Description	
5303	Guided Wave Solids Level Transmitter	★

Signal output

Code	Description	
H	4-20 mA with HART communication (default output from factory is HART 7, add option code HR5 for HART 5)	★
F	FOUNDATION Fieldbus	★
M	RS-485 with Modbus communication	★

Related information

[4-20 mA HART](#)

[FOUNDATION Fieldbus](#)

[Modbus](#)

Housing material

Code	Description	
A	Polyurethane-covered Aluminum (Aluminum alloy A360, maximum 0.6 percent Cu)	★
S	Stainless Steel, Grade CF8M (ASTM A743)	

Conduit / cable threads

Code	Description	
1	½ - 14 NPT	1 plug included ★
2	M20 x 1.5 adapter	1 adapter and 1 plug included ★

Code	Description		
4	2 pcs M20 x 1.5 adapter	2 adapters and 1 plug included	★
G ⁽¹⁾⁽²⁾	Metal cable gland (½ - 14 NPT)	2 glands and 1 plug included	★
E ⁽³⁾	M12, 4-pin, male connector (eurofast®)	1 plug included	★
M ⁽³⁾	A size Mini, 4-pin, male connector (minifast®)	1 plug included	★

- (1) Not available with explosion-proof or flameproof approvals.
- (2) Minimum temperature is -20 °C (-4 °F).
- (3) Not available with explosion-proof, flameproof, or increased safety approvals.

Operating temperature and pressure

Process seal rating. Final rating depends on Material of construction, Flange, and O-ring selection.

Code	Description	Probe type	
Standard (Std)			
S	Design and operating temperature: -40 to 302 °F (-40 to 150 °C)	Design and operating pressure: -15 to 754 psig (-1 to 52 bar) ⁽¹⁾	All ★

- (1) Maximum pressure is 580 psig (40 bar) for O-ring material code B (Nitrile Butadiene) and Overfill prevention code U1.

Related information

- [Process temperature and pressure rating](#)
- [Flange rating](#)
- [Plate design](#)
- [Tri Clamp rating](#)

Material of construction: Process connection / probe

For other materials, consult the factory.

Code	Description	Probe type	
1	316/316L/EN 1.4404	All	★

Sealing O-ring material

For other materials, consult the factory.

Code	Description	
V	Fluoroelastomer (FKM)	★
E	Ethylene Propylene (EPDM)	★
K	Kalrez® Perfluoroelastomer (FFKM)	★
B	Nitrile Butadiene (NBR)	★
F	Fluorsilicone (FVMQ)	★

Probe type

Code	Description	Process connections	Probe lengths	
5A ⁽¹⁾	Flexible Single Lead with weight, 4 mm	Flange / 1-in., 1½-in., 2-in. Thread	Min: 3 ft. 4 in. (1 m) Max: 115 ft. (35 m)	★
5B ⁽²⁾	Flexible Single Lead with chuck, 4 mm	Flange / 1-in., 1½-in., 2-in. Thread	Min: 3 ft. 4 in. (1 m) Max: 115 ft. (35 m)	★
6A ⁽³⁾	Flexible Single Lead with weight, 6 mm	Flange / 1-in., 1½-in., 2-in. Thread	Min: 3 ft. 4 in. (1 m) Max: 164 ft. (50 m)	★
6B ⁽³⁾	Flexible Single Lead with chuck, 6 mm	Flange / 1-in., 1½-in., 2-in. Thread	Min: 3 ft. 4 in. (1 m) Max: 164 ft. (50 m)	★

(1) 0.79 lb (0.36 kg) standard weight for flexible single lead probe. L=5.5 in. (140 mm).

(2) Extra length for fastening is added in factory.

(3) 1.2 lb (0.56 kg) standard weight for flexible single lead probe. L=5.5 in. (140 mm).

Probe length units

Code	Description	
E	English (feet, inches)	★
M	Metric (meters, centimeters)	★

Total probe length (feet/m)

Probe weight included if applicable. Give the total probe length in feet and inches or meters and centimeters, depending on selected probe length unit. If tank height is unknown, please round up to an even length when ordering. Probes can be cut to exact length in field. Maximum allowable length is determined by process conditions.

Code	Description	
XXX	0-164 ft. or 0-50 m	★

Related information

[Total probe length](#)

Total probe length (inch/cm)

Probe weight included if applicable. Give the total probe length in feet and inches or meters and centimeters, depending on selected probe length unit. If tank height is unknown, please round up to an even length when ordering. Probes can be cut to exact length in field. Maximum allowable length is determined by process conditions.

Code	Description	
XX	0 - 11 in. or 0-99 cm	★

Related information

[Total probe length](#)

Process connection - size / type

For other process connections, consult the factory.

Code	Description	
ASME flanges ⁽¹⁾⁽²⁾		
AA	2-in. Class 150, RF (Raised Face Type)	★
AB	2-in. Class 300, RF (Raised Face Type)	★
BA	3-in. Class 150, RF (Raised Face Type)	★
BB	3-in. Class 300, RF (Raised Face Type)	★
CA	4-in. Class 150, RF (Raised Face Type)	★
CB	4-in. Class 300, RF (Raised Face Type)	★
DA	6-in. Class 150, RF (Raised Face Type)	
DB	6-in. Class 300, RF (Raised Face Type)	
EN 1092-1 flanges ⁽³⁾		
HB	DN50, PN40, Type A flat face	★
IA	DN80, PN16, Type A flat face	★
IB	DN80, PN40, Type A flat face	★
JA	DN100, PN16, Type A flat face	★
JB	DN100, PN40, Type A flat face	★
HI	DN50, PN40, Type E spigot face	
HP	DN50, PN16, Type C tongue face	
HQ	DN50, PN40, Type C tongue face	
IH	DN80, PN16, Type E spigot face	
II	DN80, PN40, Type E spigot face	
JH	DN100, PN16, Type E spigot face	
JI	DN100, PN40, Type E spigot face	
JQ	DN100, PN40, Type C tongue face	
KA	DN150, PN16, Type A flat face	
KB	DN150, PN40 Type A flat face	
KH	DN150, PN16, Type E spigot face	
NI	DN65, PN40, Type E spigot face	
JIS flanges ⁽³⁾		
UA	50A, 10K, RF (Raised Face Type)	★
VA	80A, 10K, RF (Raised Face Type)	★
XA	100A, 10K, RF (Raised Face Type)	★
Threaded connections ⁽²⁾		Probe type
RA	1½-in. NPT thread	All
RC	2-in. NPT thread	All

Code	Description	
RB	1-in. NPT thread	All
SA	1½-in. BSP (G 1½-in.) thread	All
SB	1-in. BSP (G 1-in.) thread	All

- (1) Design according to ASME B31.3. No code stamp or ASME certificate available.
- (2) Available in 316L. For other materials, consult the factory.
- (3) Available in 316L and EN 1.4404. For other materials consult the factory.

Hazardous locations certifications

Code	Description	
NA	No Hazardous Locations Certifications	★
E1 ⁽¹⁾	ATEX/UKEX Flameproof	★
E3 ⁽¹⁾	China Flameproof	★
E5 ⁽¹⁾	USA Explosion-proof	★
E6 ⁽¹⁾	Canadian Explosion-proof	★
E7 ⁽¹⁾	IECEX Flameproof	★
I1	ATEX/UKEX Intrinsic Safety	★
IA ⁽²⁾	ATEX/UKEX FISCO Intrinsic Safety	★
I3	China Intrinsic Safety	★
IC ⁽²⁾	China FISCO Intrinsic Safety	★
I5	USA Intrinsic Safety and Non-Incendive	★
IE ⁽²⁾	USA FISCO Intrinsic Safety	★
I6	Canadian Intrinsic Safety	★
IF ⁽²⁾	Canadian FISCO Intrinsic Safety	★
I7	IECEX Intrinsic Safety	★
IG ⁽²⁾	IECEX FISCO Intrinsic Safety	★
E2 ⁽¹⁾	INMETRO Flameproof	
EM ⁽¹⁾	Technical Regulations Customs Union (EAC) Flameproof	
I2	INMETRO Intrinsic Safety	
IB ⁽²⁾	INMETRO FISCO Intrinsic Safety	
IM	Technical Regulations Customs Union (EAC) Intrinsic Safety	
IN ⁽²⁾	Technical Regulations Customs Union (EAC) FISCO Intrinsic Safety	
EW	India PESO Flameproof	
IW	India PESO Intrinsic Safety	
E4 ⁽¹⁾	Japan Flameproof	
EP ⁽¹⁾⁽³⁾	Republic of Korea Flameproof	
KA ⁽¹⁾	ATEX/UKEX, USA, Canadian Flameproof/Explosion-proof	
KB ⁽¹⁾	ATEX/UKEX, USA, IECEX Flameproof/Explosion-proof	

Code	Description
KC ⁽¹⁾	ATEX/UKEX, Canadian, IECEx Flameproof/Explosion-proof
KD ⁽¹⁾	USA, Canadian, IECEx Flameproof/Explosion-proof
KE	ATEX/UKEX, USA, Canadian Intrinsic Safety
KF	ATEX/UKEX, USA, IECEx Intrinsic Safety
KG	ATEX/UKEX, Canadian, IECEx Intrinsic Safety
KH	USA, Canadian, IECEx Intrinsic Safety
KI ⁽²⁾	FISCO - ATEX/UKEX, USA, Canadian Intrinsic Safety
KJ ⁽²⁾	FISCO - ATEX/UKEX, USA, IECEx Intrinsic Safety
KK ⁽²⁾	FISCO - ATEX/UKEX, Canadian, IECEx Intrinsic Safety
KL ⁽²⁾	FISCO - USA, Canadian, IECEx Intrinsic Safety
N1	ATEX/UKEX Increased Safety
N7	IECEx Increased Safety

(1) Probes are intrinsically safe.

(2) Requires FOUNDATION Fieldbus signal output (U_i parameter listed in Product Certifications).

(3) The EP (Republic of Korea Flameproof) certificate is based on the E7 (IECEx Flameproof) certificate, therefore model code E7 is stated in the certificate instead of EP.

Related information

[Product certifications](#)

Additional options

Display

Code	Description
M1	Integral digital display

Communication

Code	Description
HR5	4–20 mA with digital signal based on HART 5 protocol
HR7	4–20 mA with digital signal based on HART 7 protocol

Hydrostatic testing

Available for tank connection with flange.

Code	Description
P1	Hydrostatic testing, including certificate

Factory configuration

Code	Description
C1	Factory configuration per Configuration Data Sheet

Alarm limits

Code	Description	
C4	NAMUR alarm and saturation levels, high alarm	★
C5	NAMUR alarm and saturation levels, low alarm	★
C8 ⁽¹⁾	Standard Rosemount alarm and saturation levels, low alarm	★

(1) The standard alarm setting is high.

Welding procedure qualification record documentation

Weldings in accordance with EN/ISO standards.

Code	Description	
Q66	Welding Procedure Qualification Record (WPQR)	★
Q67	Welder Performance Qualification (WPQ)	★
Q68	Welding Procedure Specification (WPS)	★

Special quality assurance

Code	Description	
Q4	Calibration data certificate	★
QG	Calibration certificate and GOST verification certificate (only for end-destination country Russia)	

Material traceability certification

Certificate includes all pressure retaining wetted parts.

Code	Description	
Q8	Material traceability certification consistent with ISO10474-3.1:2013 / EN10204-3.1:2004	★

Safety certifications

Code	Description	
QS	Prior-use certificate of FMEDA Data. Only available with HART 4-20 mA output (output code H).	★
QT	Safety-certified to IEC 61508 with certificate of FMEDA data. Only available with HART 4-20 mA output (output code H).	★

Dye penetration test certificate

Code	Description	
Q73	Certificate of liquid penetrant inspection	★

Positive material identification certificate

Code	Description	
Q76	Positive material identification certificate of conformance	★

Installation options

Code	Description	
LS ⁽¹⁾	Long stud 9.8 in (250 mm) for flexible single lead probe to prevent contact with wall/nozzle. Standard stud length is 3.9 in (100 mm) for probes 5A and 5B. Standard stud length is 5.9 in (150 mm) for probes 6A and 6B.	★
BR	316L Mounting Bracket for 1½-in. NPT Process Connection (RA)	

(1) Not available with PTFE covered probes.

Related information

[Dimensional drawings](#)

Transient protection

Code	Description	
T1	Transient Protection Terminal Block. Selectable with HART 4-20 mA output (output code H). Already included in all FOUNDATION Fieldbus variations.	★

Diagnostic functionality

Code	Description	
D01	FOUNDATION Fieldbus Diagnostics Suite (includes Signal Quality Metrics diagnostics)	★
DA1	HART Diagnostics Suite (includes Signal Quality Metrics diagnostics)	★

Related information

[Diagnostics Suite](#)

Overfill prevention

Code	Description	
U1	Overfill prevention according to WHG/TUV	★

Extended product warranty

Rosemount extended warranties have a limited warranty of three or five years from date of shipment.

Code	Description	
WR3	3-year limited warranty	★
WR5	5-year limited warranty	★

Remote housing

Not available with Marine/shipboard approvals.

Code	Description	
B1	1 m/3.2 ft. Remote housing mounting cable and 316L bracket	
B2	2 m/6.5 ft. Remote housing mounting cable and 316L bracket	
B3	3 m/9.8 ft. Remote housing mounting cable and 316L bracket	

Related information

[Dimensional drawings](#)

Specials

Code	Description	
RXXXX	Custom engineered solutions beyond standard model codes. Consult factory for details.	

Related information

[Engineered solutions](#)

Accessories

Weight kit

Item number	Description	
03300-7001-0002	Weight kit flexible twin lead	
03300-7001-0003	Weight kit flexible 4 mm single lead	
03300-7001-0004	Weight kit flexible 6 mm single lead	

Centering discs for rigid single lead probe (d=0.3 in./8 mm)

If a centering disc is required for a flanged probe, the centering disc can be ordered with options Sx or Px in the model code. If a centering disc is required for a threaded connection, or as a spare part, it should be ordered using the item numbers listed in this table.

For other materials, consult the factory.

Item number	Description	Outer diameter	
03300-1655-0001	Kit, 2-in. Centering disc, SST	1.8 in. (45 mm)	★
03300-1655-0006	Kit, 2-in. Centering disc, PTFE	1.8 in. (45 mm)	★
03300-1655-0002	Kit, 3-in. Centering disc, SST	2.7 in. (68 mm)	★
03300-1655-0007	Kit, 3-in. Centering disc, PTFE	2.7 in. (68 mm)	★
03300-1655-0003	Kit, 4-in. Centering disc, SST	3.6 in. (92 mm)	★
03300-1655-0008	Kit, 4-in. Centering disc, PTFE	3.6 in. (92 mm)	★
03300-1655-0004	Kit, 6-in. Centering disc, SST	5.55 in. (141 mm)	
03300-1655-0009	Kit, 6-in. Centering disc, PTFE	5.55 in. (141 mm)	
03300-1655-0005	Kit, 8-in. Centering disc, SST	7.40 in. (188 mm)	
03300-1655-0010	Kit, 8-in. Centering disc, PTFE	7.40 in. (188 mm)	

Related information

[Centering disc for pipe installations](#)

Centering discs for rigid single lead probe (d=0.5 in./13 mm)

If a centering disc is required for a flanged probe, the centering disc can be ordered with options Sx or Px in the model code. If a centering disc is required for a threaded connection, or as a spare part, it should be ordered using the item numbers listed in this table.

For other materials, consult the factory.

Item number	Description	Outer diameter	
03300-1655-0301	Kit, 2-in. Centering disc, SST	1.8 in. (45 mm)	★
03300-1655-0306	Kit, 2-in. Centering disc, PTFE	1.8 in. (45 mm)	★
03300-1655-0302	Kit, 3-in. Centering disc, SST	2.7 in. (68 mm)	★
03300-1655-0307	Kit, 3-in. Centering disc, PTFE	2.7 in. (68 mm)	★
03300-1655-0303	Kit, 4-in. Centering disc, SST	3.6 in. (92 mm)	★

Item number	Description	Outer diameter	
03300-1655-0308	Kit, 4-in. Centering disc, PTFE	3.6 in. (92 mm)	★
03300-1655-0304	Kit, 6-in. Centering disc, SST	5.55 in. (141 mm)	
03300-1655-0309	Kit, 6-in. Centering disc, PTFE	5.55 in. (141 mm)	
03300-1655-0305	Kit, 8-in. Centering disc, SST	7.40 in. (188 mm)	
03300-1655-0310	Kit, 8-in. Centering disc, PTFE	7.40 in. (188 mm)	

Related information

[Centering disc for pipe installations](#)

Snap-on centering discs for flexible single lead probes

Maximum temperature for the snap-on centering discs is 392 °F (200 °C).

Item number	Description	
03300-1658-0001	Kit, 2- to 4-in. snap-on centering disc, PEEK, 1 pc	
03300-1658-0002	Kit, 2- to 4-in. snap-on centering disc, PEEK, 3 pcs	
03300-1658-0003	Kit, 2- to 4-in. snap-on centering disc, PEEK, 5 pcs	

Centering discs for flexible single/twin lead probes

If a centering disc is required for a flanged probe, the centering disc can be ordered with options Sx or Px in the model code. If a centering disc is required for a threaded connection, or as a spare part, it should be ordered using the item numbers listed in this table.

For other materials, consult the factory.

Item number	Description	Outer diameter	
03300-1655-1001	Kit, 2-in. Centering disc, SST	1.8 in. (45 mm)	★
03300-1655-1006	Kit, 2-in. Centering disc, PTFE	1.8 in. (45 mm)	★
03300-1655-1002	Kit, 3-in. Centering disc, SST	2.7 in. (68 mm)	★
03300-1655-1007	Kit, 3-in. Centering disc, PTFE	2.7 in. (68 mm)	★
03300-1655-1003	Kit, 4-in. Centering disc, SST	3.6 in. (92 mm)	★
03300-1655-1008	Kit, 4-in. Centering disc, PTFE	3.6 in. (92 mm)	★
03300-1655-1004	Kit, 6-in. Centering disc, SST	5.55 in. (141 mm)	
03300-1655-1009	Kit, 6-in. Centering disc, PTFE	5.55 in. (141 mm)	
03300-1655-1005	Kit, 8-in. Centering disc, SST,	7.40 in. (188 mm)	
03300-1655-1010	Kit, 8-in. Centering disc, PTFE	7.40 in. (188 mm)	

Related information

[Centering disc for pipe installations](#)

Centering discs for mounting between segments (probe type 4S only)

Item number	Description	Outer diameter
03300-1656-1002	2-in. Centering disc (1 pc), PTFE, Segmented rigid single lead	1.8 in. (45 mm)
03300-1656-1003	3-in. Centering disc (1 pc), PTFE, Segmented rigid single lead	2.7 in. (68 mm)
03300-1656-1004	4-in. Centering disc (1 pc), PTFE, Segmented rigid single lead	3.6 in. (92 mm)
03300-1656-1006	6-in. Centering disc (1 pc), PTFE, Segmented rigid single lead	5.55 in. (141 mm)
03300-1656-1008	8-in. Centering disc (1 pc), PTFE, Segmented rigid single lead	7.40 in. (188 mm)
03300-1656-3002	2-in. Centering disc (3 pcs), PTFE, Segmented rigid single lead	1.8 in. (45 mm)
03300-1656-3003	3-in. Centering disc (3 pcs), PTFE, Segmented rigid single lead	2.7 in. (68 mm)
03300-1656-3004	4-in. Centering disc (3 pcs), PTFE, Segmented rigid single lead	3.6 in. (92 mm)
03300-1656-3006	6-in. Centering disc (3 pcs), PTFE, Segmented rigid single lead	5.55 in. (141 mm)
03300-1656-3008	8-in. Centering disc (3 pcs), PTFE, Segmented rigid single lead	7.40 in. (188 mm)
03300-1656-5002	2-in. Centering disc (5 pcs), PTFE, Segmented rigid single lead	1.8 in. (45 mm)
03300-1656-5003	3-in. Centering disc (5 pcs), PTFE, Segmented rigid single lead	2.7 in. (68 mm)
03300-1656-5004	4-in. Centering disc (5 pcs), PTFE, Segmented rigid single lead	3.6 in. (92 mm)
03300-1656-5006	6-in. Centering disc (5 pcs), PTFE, Segmented rigid single lead	5.55 in. (141 mm)
03300-1656-5008	8-in. Centering disc (5 pcs), PTFE, Segmented rigid single lead	7.40 in. (188 mm)

Segmented rigid single lead probe spare part kit

Item number	Description
03300-0050-0001	15.2 in. / 385 mm Segment for Top connection (1 pc)
03300-0050-0002	31.5 in. / 800 mm Segment (1 pc)
03300-0050-0003	31.5 in. / 800 mm Segment (3 pcs)
03300-0050-0004	31.5 in. / 800 mm Segment (5 pcs)
03300-0050-0005	31.5 in. / 800 mm Segment (12 pcs)

Vented flanges

1-½ in. NPT threaded connection (RA) is required.

Not available with Country certification option code J1, J2, J7, or J8.

Not available for Probe type code 3C.

Item number	Description
03300-1812-0092	Fisher™ (249B, 259B), one ¼-in. NPT connection, 316/316L
03300-1812-0093	Fisher (249C), one ¼-in. NPT connection, 316/316L
03300-1812-0091	Masoneilan™, one ¼-in. NPT connection, 316/316L

Flushing connection rings

Not available with Country certification option code J1, J2, J7, or J8.

Item number	Description	
DP0002-2111-S6	2-in. ANSI, one ¼-in. NPT connection, 316L	
DP0002-3111-S6	3-in. ANSI, one ¼-in. NPT connection, 316L	
DP0002-4111-S6	4-in. ANSI/DN100, one ¼-in. NPT connection, 316L	
DP0002-5111-S6	DN50, one ¼-in. NPT connection, 316L	
DP0002-8111-S6	DN80, one ¼-in. NPT connection, 316L	

HART modem and cables

Item number	Description	
03300-7004-0001	MACTek® VIATOR® HART Modem and cables (RS232 connection)	★
03300-7004-0002	MACTek VIATOR HART Modem and cables (USB connection)	★

Remote housing mounting spare part kit

Item number	Description	
03300-7006-0001	1 m / 3.2 ft. Remote Housing Mounting Cable and 316L Bracket	
03300-7006-0002	2 m / 6.5 ft. Remote Housing Mounting Cable and 316L Bracket	
03300-7006-0003	3 m / 9.8 ft. Remote Housing Mounting Cable and 316L Bracket	

Heat sink

Item number	Description	
05300-7001-0001	Heat sink	

Verification reflector (high level supervision) spare part kit

Requires Rosemount 5300 firmware version 2.H0 or later.

Item number	Description	
05300-7200-0001	For 3- to 8-in. pipe/chamber (inner diameter)	
05300-7200-0002	For tanks or 10-in. pipe/chamber (inner diameter) or wider	

Specifications

Performance specifications

General

Reference conditions

Single Standard probe, 77 °F (25 °C) in water (DC=80) and ambient pressure in a 4-in. pipe using Trim Near Zone function.

Reference accuracy

± 0.12 in. (3 mm) or 0.03% of measured distance, whichever is greatest

For probes with spacers, the accuracy may deviate close to the spacers. Accuracy may be affected by remote housing.

Repeatability

± 0.04 in. (1 mm)⁽¹⁾

Ambient temperature effect

± 0.008 in. (0.2 mm) /°K or ± 30 ppm/°K of measured value, whichever is greatest⁽²⁾

Electromagnetic interference effect

- Shielded cable: ± 0.2 in. (5 mm)⁽³⁾
- Unshielded cable: ± 2 in. (50 mm)⁽³⁾

For FOUNDATION™ Fieldbus units it may be required to ground the signal cable shield at the power supply and transmitter to achieve optimum performance.

Thresholds may need to be adjusted, see the Rosemount 5300 [Reference Manual](#) for general guidelines on manual threshold settings.

Update interval

Minimum 1 update per second

Environment

Vibration resistance

- Aluminum housing: Level 1 IEC 60770-1/IEC 61298-3 ed 1 chapter 7, IACS E10
- Stainless Steel housing: IACS E10

Electromagnetic compatibility

Emission and Immunity: EMC directive 2014/30/EU, EN 61326-1:2013, and EN61326-3-1:2006.

NAMUR recommendations: NE21⁽⁴⁾

CE-mark

Complies with applicable directives (EMC, ATEX).

(1) In accordance with IEC 60770-1. See the IEC 60770-1 standard for a definition of radar specific performance parameters and if applicable corresponding test procedures.

(2) For the BR5 option code with ambient temperatures between -67 °F (-55 °C) and -40 °F (-40 °C), the ambient temperature effect is ± 0.012 in. (0.3 mm) /°K or ± 45 ppm/°K of measured value, whichever is greatest.

(3) Deviation through electromagnetic interference according to EN 61326.

(4) Namur NE21 not available with option code QT.

Built-in lightning protection

EN 61326, IEC 61000-4-5, level 2kV (6kV with T1 terminal block)

Contamination/product build-up

- Single lead probes are preferred when there is a risk of contamination (because build-up can result in the product bridging across the two leads for twin versions; between the inner lead and outer pipe for the coaxial versions).
- For viscous or sticky applications, PTFE probes are recommended. Periodic cleaning may also be required.
- For viscous or sticky applications, it is not recommended to use centering discs mounted along the single lead probe.
- Signal Quality Metrics (option code D01, or DA1) can be used to determine when to clean the probe. Transmitters equipped with the Diagnostics Suite option can calculate Signal Quality Metrics.

Table 1: Maximum Recommended Viscosity and Contamination/Build-up

Probe type	Maximum viscosity	Contamination/build-up
Single lead	8000 cP ⁽¹⁾⁽²⁾	Build-up allowed
Twin lead/Large coaxial	1500 cP	Thin build-up allowed, but no bridging
Coaxial	500 cP	Not recommended

- (1) Consult your local Emerson representative in the case of agitation/turbulence and high viscous products.
 (2) Be cautious in HTHP viscous or crystallizing media applications where temperature at instrument connection is significantly lower than process temperature with risk of coating in the upper part of probe that may reduce the measurement signal. Consider using HP or STD probes in such applications.

Measuring range

See [Table 2](#) and [Table 3](#) for each probe’s measuring range and minimum dielectric constant. Due to the measuring range depending on the application and factors described below, the values are a guideline for clean liquids. For more information, ask your local Emerson representative.

Note

For Remote Housing, see [Table 4](#) and [Table 5](#) for the maximum recommended measuring range for different remote housing lengths, installation types, dielectric constants, and probe types.

Different parameters (factors) affect the echo and therefore the maximum measuring range differs depending on application according to:

- Disturbing objects close to the probe.
- Media with higher dielectric constant (ϵ_r) gives better reflection and allows a longer measuring range.
- Surface foam and particles in the tank atmosphere may affect measuring performance.
- Heavy product build-up or contamination on the probe should be avoided since it can reduce measuring range and might cause erroneous level readings.

Table 2: Maximum Measuring Range

Probe type	Maximum measuring range
Rigid single lead/segmented rigid single lead	9 ft. 10 in. (3 m) for 8 mm probes (code 4A) 19 ft. 8 in. (6 m) for 13 mm probes (code 4B) 32 ft. 9 in. (10 m) for 13 mm probes (code 4S)
Flexible single lead	164 ft. (50 m) ⁽¹⁾
Coaxial	19 ft. 8 in. (6 m)
Large coaxial	19 ft. 8 in. (6 m)
Rigid twin lead	9 ft. 10 in. (3 m)
Flexible twin lead	164 ft. (50 m)

(1) Maximum measuring range for Duplex 2205 probes type 5A and 5B is 105 ft. (32 m).

Table 3: Minimum Dielectric Constant

Probe type	Minimum dielectric constant			
	Std	HP	HTHP	C
Rigid single lead/ segmented rigid single lead	1.4 ⁽¹⁾⁽²⁾ (1.25 if installed in a metallic bypass or stilling well)	1.6 ⁽¹⁾⁽²⁾ (1.4 if installed in a metallic bypass or stilling well)		
Flexible single lead	1.4, up to 49 ft. (15 m) ⁽¹⁾ 1.8, up to 82 ft. (25 m) ⁽¹⁾ 2.0, up to 115 ft. (35 m) ⁽¹⁾⁽³⁾ 3, up to 138 ft. (42 m) 4, up to 151 ft. (46 m) 6, up to 164 ft. (50 m)	1.6, up to 49 ft. (15 m) ⁽¹⁾ 1.8, up to 82 ft. (25 m) ⁽¹⁾ 2.0, up to 115 ft. (35 m) ⁽¹⁾⁽³⁾ 3, up to 138 ft. (42 m) 4, up to 151 ft. (46 m) 6, up to 164 ft. (50 m)		
Coaxial	1.2	1.4	2.0	1.4
Large coaxial	1.2	1.4	N/A	1.4
Rigid twin lead	1.4	N/A	N/A	N/A
Flexible twin lead	1.4, up to 82 ft. (25 m) ⁽¹⁾ 2.0, up to 115 ft. (35 m) ⁽¹⁾ 2.5, up to 131 ft. (40 m) ⁽¹⁾ 3.5, up to 148 ft. (45 m) 6, up to 164 ft. (50 m)	N/A	N/A	N/A

(1) Probe end projection software function will improve the minimum measurable dielectric constant. Consult the factory for details.

(2) May be lower depending on installation.

(3) Up to 49 ft. (15 m) for Duplex 2205 probes type 5A and 5B.

Table 4: Remote Housing Measuring Range for Tank Installations, ft. (m)

Probe type ⁽¹⁾	1 m remote housing			2 m remote housing			3 m remote housing		
	DC 1.4	DC 2	DC 80	DC 1.4	DC 2	DC 80	DC 1.4	DC 2	DC 80
Rigid single 8 mm	4 (1.25)	4 (1.25)	10 (3) ⁽²⁾	9 (2.75)	9 (2.75)	10 (3) ⁽²⁾	10 (3)	10 (3)	10 (3)
Rigid single 13 mm	4 (1.25)	4 (1.25)	19 (6) ⁽²⁾	9 (2.75)	9 (2.75)	19 (6) ⁽²⁾	14 (4.25)	14 (4.25)	19 (6) ⁽²⁾
Segmented rigid single	4 (1.25)	4 (1.25)	33 (10) ⁽²⁾	9 (2.75)	9 (2.75)	33 (10) ⁽²⁾	14 (4.25)	14 (4.25)	33 (10) ⁽²⁾
Flexible single	4 (1.25)	4 (1.25)	159 (48.5) ⁽²⁾	9 (2.75)	9 (2.75)	154 (47) ⁽²⁾	14 (4.25)	14 (4.25)	149 (45.5) ⁽²⁾
Coaxial/Large coaxial	19 (6)	19 (6)	19 (6)	19 (6)	19 (6)	19 (6)	19 (6)	19 (6)	19 (6)
Rigid twin	4 (1.25)	4 (1.25)	10 (3) ⁽²⁾	9 (2.75)	9 (2.75)	10 (3) ⁽²⁾	10 (3) ⁽²⁾	10 (3) ⁽²⁾	10 (3) ⁽²⁾
Flexible twin	4 (1.25)	98 (30) ⁽²⁾	159 (48.5) ⁽²⁾	9 (2.75)	98 (30) ⁽²⁾	154 (47) ⁽²⁾	14 (4.25)	98 (30) ⁽²⁾	149 (45.5) ⁽²⁾

(1) Validated for ambient temperature range -40 °F to 185 °F (-40 °C to 85 °C).

(2) Accuracy may be affected up to ± 1.2 in. (30 mm).

Table 5: Remote Housing Measuring Range for Chamber/Pipe Installations < 4 in. (100 mm), ft. (m)

Probe type ⁽¹⁾	1 m remote housing			2 m remote housing			3 m remote housing		
	DC 1.4	DC 2	DC 80	DC 1.4	DC 2	DC 80	DC 1.4	DC 2	DC 80
Rigid single 8 mm	4 (1.25)	10 (3) ⁽²⁾	10 (3)	9 (2.75)	10 (3) ⁽²⁾	10 (3)	10 (3)	10 (3)	10 (3)
Rigid single 13 mm	19 (6) ⁽²⁾	19 (6) ⁽²⁾	19 (6) ⁽²⁾	19 (6) ⁽²⁾	19 (6) ⁽²⁾	19 (6)	19 (6)	19 (6)	19 (6)
Segmented rigid single	33 (10) ⁽²⁾	33 (10) ⁽²⁾	33 (10) ⁽²⁾	33 (10) ⁽²⁾	33 (10) ⁽²⁾	33 (10)	33 (10)	33 (10)	33 (10)
Flexible single ⁽³⁾	33 (10) ⁽²⁾	33 (10) ⁽²⁾	33 (10) ⁽²⁾	33 (10) ⁽²⁾	33 (10) ⁽²⁾	33 (10) ⁽²⁾	33 (10) ⁽²⁾	33 (10) ⁽²⁾	33 (10) ⁽²⁾
Coaxial/Large coaxial	19 (6)	19 (6)	19 (6)	19 (6)	19 (6)	19 (6)	19 (6)	19 (6)	19 (6)
Rigid twin	10 (3) ⁽²⁾	10 (3) ⁽²⁾	10 (3) ⁽²⁾	10 (3) ⁽²⁾	10 (3) ⁽²⁾	10 (3) ⁽²⁾	10 (3) ⁽²⁾	10 (3) ⁽²⁾	10 (3) ⁽²⁾
Flexible twin ⁽³⁾	33 (10) ⁽²⁾	33 (10) ⁽²⁾	33 (10) ⁽²⁾	33 (10) ⁽²⁾	33 (10) ⁽²⁾	33 (10) ⁽²⁾	33 (10) ⁽²⁾	33 (10) ⁽²⁾	33 (10) ⁽²⁾

(1) Validated for ambient temperature range -40 °F to 185 °F (-40 °C to 85 °C).

(2) Accuracy may be affected up to ± 1.2 in. (30 mm).

(3) Required chamber/pipe size is 3 or 4 in. (75 - 100 mm).

Interface measuring range

The maximum allowable upper product thickness/measuring range is primarily determined by the dielectric constants of the two liquids.

Typical applications include interfaces between oil/oil-like and water/water-like liquids, with a low (<3) dielectric constant for the upper product and a high (>20) dielectric constant for the lower product. For such applications, the maximum measuring range is limited by the length of the coaxial, large coaxial, rigid twin, and rigid single lead probes.

For flexible probes, the maximum measuring range is reduced by the maximum upper product thickness, according to the diagram below. However, characteristics may vary between the different applications. Maximum distance to the interface is 164 ft. (50 m) minus the maximum upper product thickness.

Figure 3: Maximum Upper Product Thickness for the Flexible Single Lead Probe

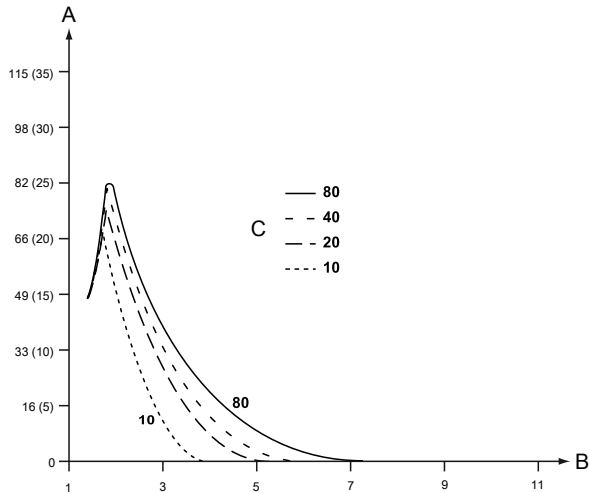

- A. Maximum upper product thickness, ft. (m)
- B. Upper product dielectric constant
- C. Lower product dielectric constant

Figure 4: Maximum Upper Product Thickness for the Flexible Twin Lead Probe

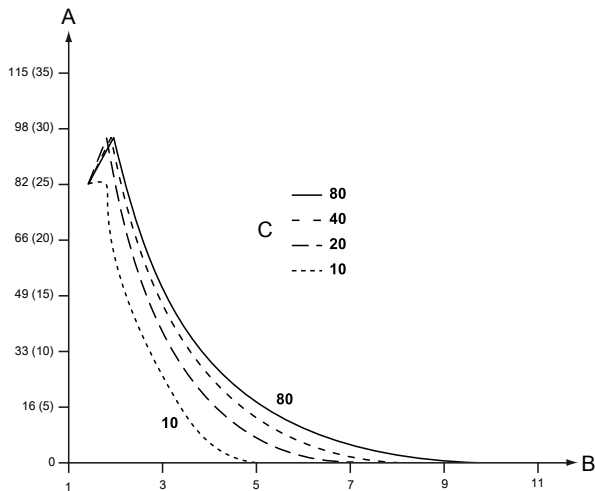

- A. Maximum upper product thickness, ft. (m)
- B. Upper product dielectric constant
- C. Lower product dielectric constant

Accuracy over measuring range

The measuring range depends on probe type, dielectric constant of the product and installation environment, and is limited by the Blind Zones at the very top and bottom of the probe. In the Blind Zones, the accuracy exceeds ±1.18 in. (30 mm), and measurements may not be possible. Measurements close to the Blind Zones will have reduced accuracy.

The following conditions will impact the Blind Zones:

- If the single lead probes or twin probes are installed in a nozzle, the nozzle height shall be added to the specified Upper Blind Zone.
- The measuring range for the PTFE covered flexible single lead probe includes the weight when measuring on a high dielectric media.
- When using a metallic centering disc, the Lower Blind Zone is 8 in. (20 cm), including weight if applicable. When using a PTFE centering disc, the Lower Blind Zone is not affected.

Figure 5: Blind Zones

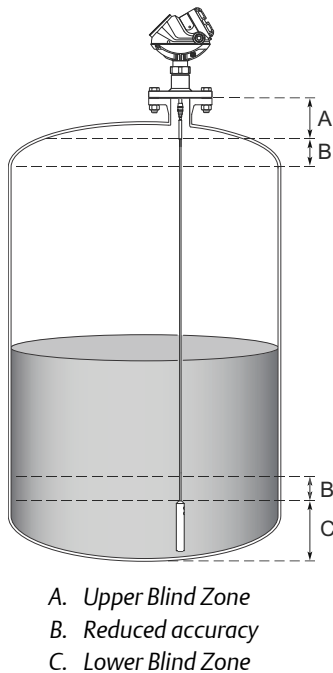

Note

Measurements may not be possible in the Blind Zones, and measurements close to the Blind Zones will have reduced accuracy. Therefore, the 4-20 mA points should be configured outside these zones.

Figure 6 , Figure 7 , Figure 8 , and Figure 9 illustrate the accuracy over measuring range at reference condition with alternating probe types and varying dielectric constant of the product.

Figure 6: Accuracy Over Measuring Range for Single Lead Probes (Rigid/Segmented Rigid/Flexible)

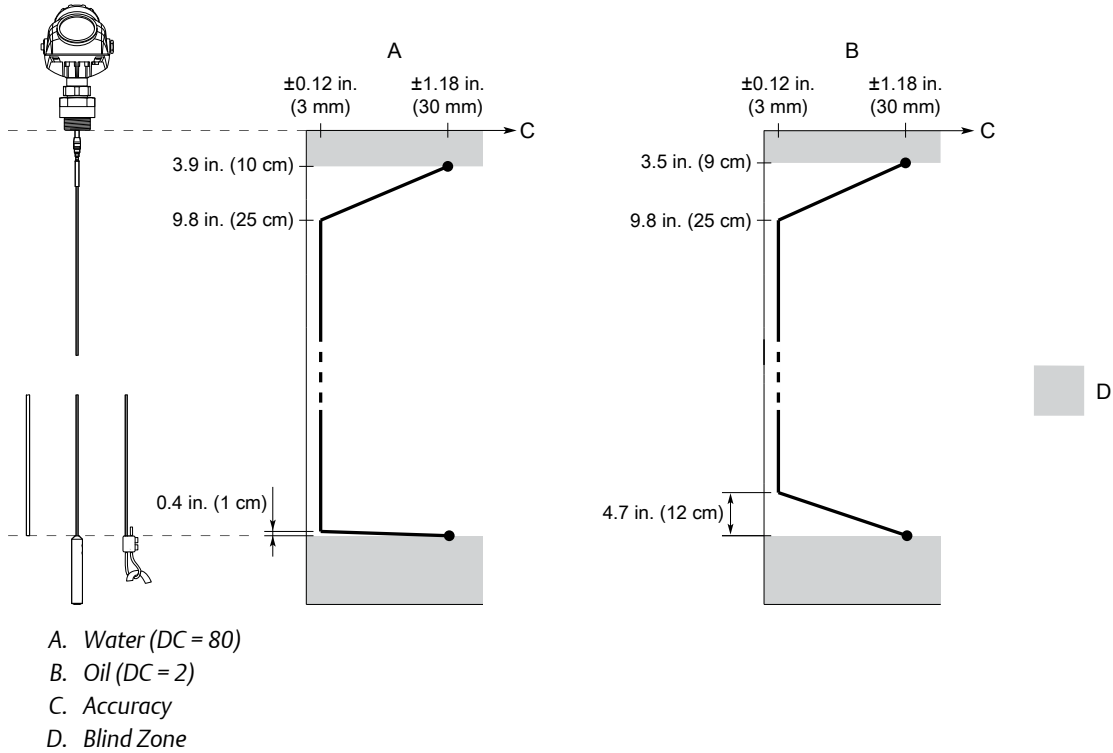

Figure 7: Accuracy Over Measuring Range for Twin Lead Probes

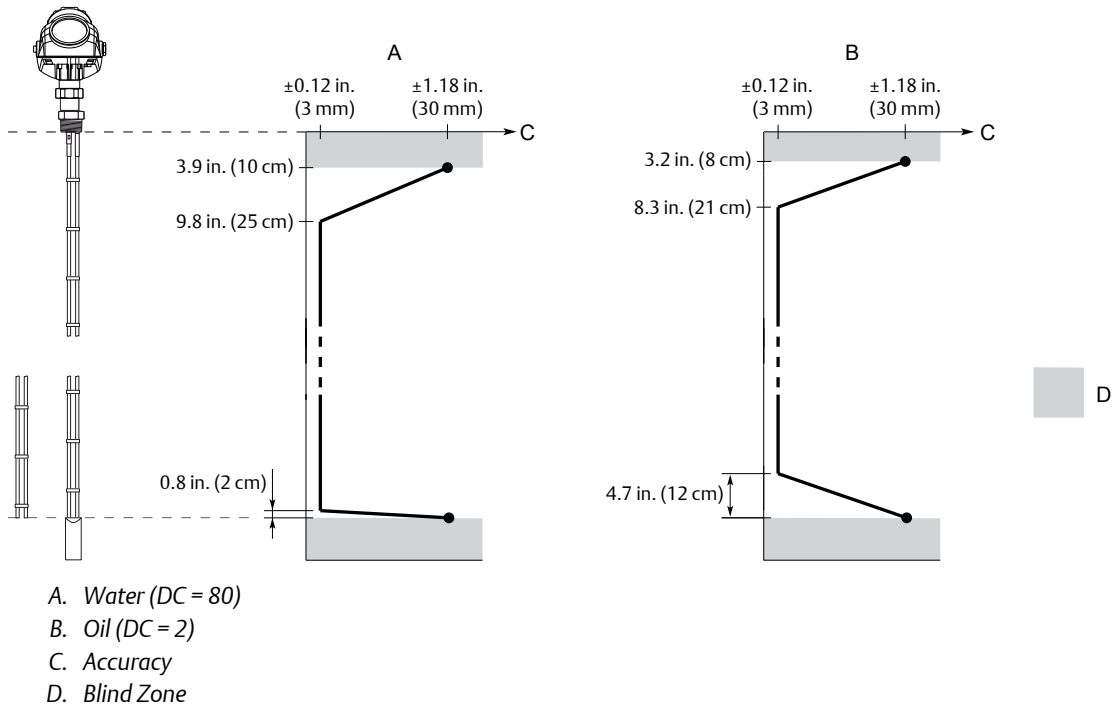
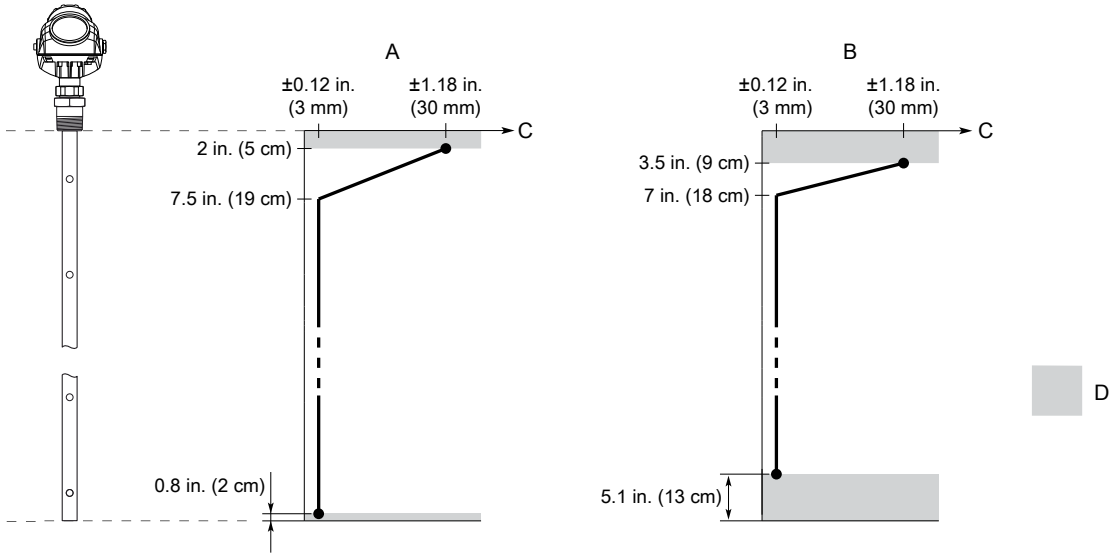
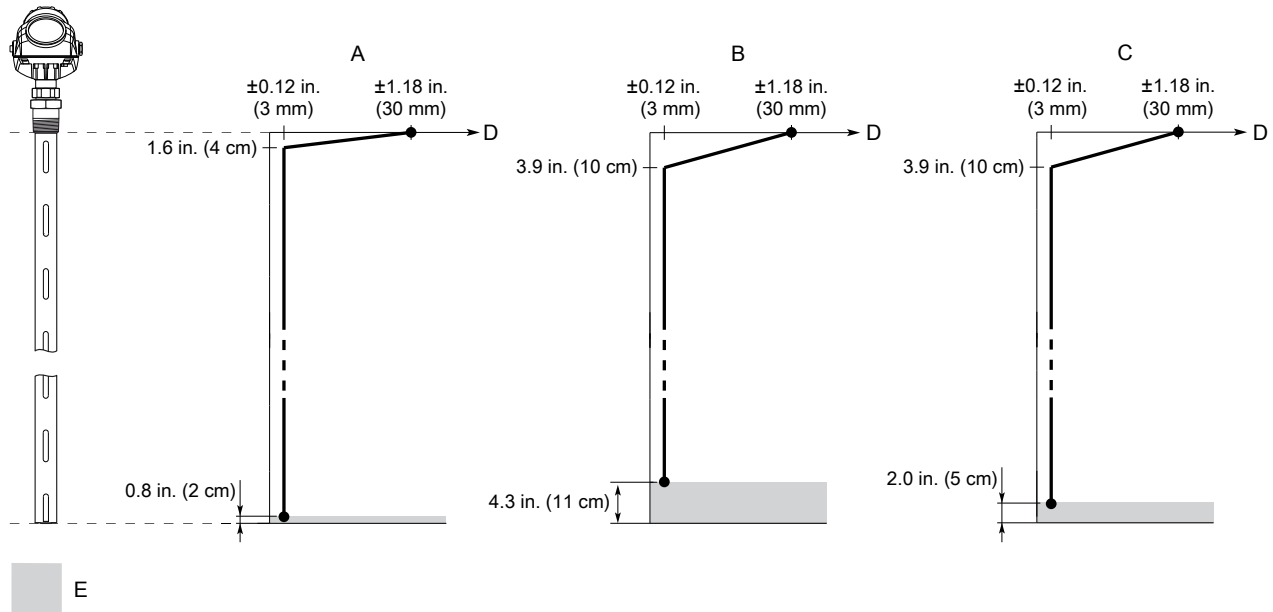

Figure 8: Accuracy Over Measuring Range for Coaxial Probe



- A. Water (DC = 80)
- B. Oil (DC = 2)
- C. Accuracy
- D. Blind Zone

Figure 9: Accuracy Over Measuring Range for Large Coaxial Probe



- A. Water (DC = 80)
- B. Oil (DC = 2), Liquid product level measurement mode
- C. Oil (DC = 2), Liquid product level and interface level measurement mode
- D. Accuracy
- E. Blind Zone

Functional specifications

General

Field of application

Liquids and semi-liquids level and/or liquid/liquid interfaces or solids level

- Model 5301, for liquid level or submerged interface measurements
- Model 5302, for liquid level, liquid level and interface, or solid level measurements
- Model 5303, for solid level measurements

Measurement principle

Time Domain Reflectometry (TDR)

Related information

[Measurement principle](#)

Microwave output power

Nominal 300 μ W, Max. 45 mW

EMC

FCC part 15 subpart B and EMC Directive (2014/30/EU). Considered to be an unintentional radiator under the Part 15 rules.

Humidity

0 to 100% relative humidity

Safety response time

< 8 s at damping value 2 s

The safety response time will be a function of the configured damping value.

Start-up time

< 40 s⁽⁵⁾

Start-up sequence

For the Rosemount™ 5300, the radar will first go to Low Alarm current for nine seconds during boot-up followed by nine seconds of High Alarm or Low Alarm current depending on alarm mode. After that measurement is re-established and the 4-20mA output settles at the actual level value.⁽⁶⁾ Refer to [Figure 10](#) and [Figure 11](#). If a different start-up behavior is preferred, contact your local Emerson representatives.

(5) The start-up time is extended with five additional minutes for option code BR5 at temperatures below -40 °F (-40 °C). Refer to [Start-up sequence](#).

(6) For devices with option code BR5 at temperatures below -40 °F (-40 °C), the start-up sequence is delayed for five minutes with an undefined current value.

Figure 10: Start-Up Sequence, Alarm Mode High

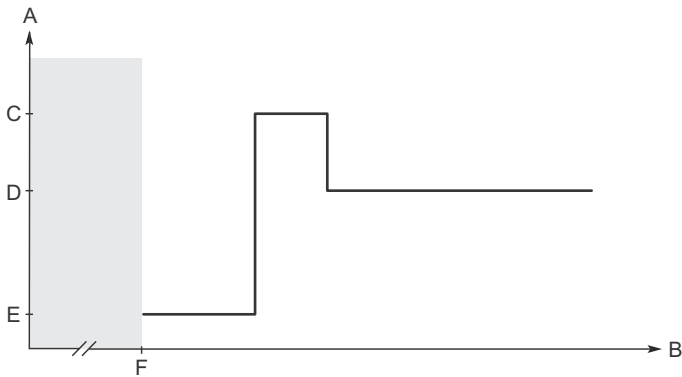

- A. Current, mA
- B. Time, s
- C. High Alarm current (Rosemount or Namur value, according to configuration)
- D. Actual level value
- E. Low Alarm current (Rosemount or Namur value, according to configuration)
- F. For option code BR5 at temperatures below -40 °F (-40 °C): Five minutes delay with an undefined current value

Figure 11: Start-Up Sequence, Alarm Mode Low

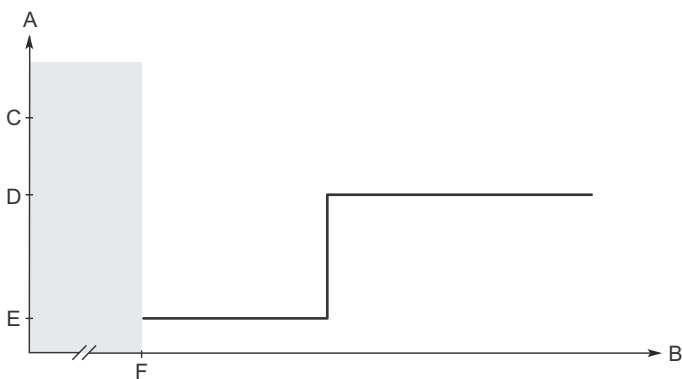

- A. Current, mA
- B. Time, s
- C. High Alarm current (Rosemount or Namur value, according to configuration)
- D. Actual level value
- E. Low Alarm current (Rosemount or Namur value, according to configuration)
- F. For option code BR5 at temperatures below -40 °F (-40 °C): Five minutes delay with an undefined current value

4-20 mA HART®

Output

Two-wire, 4-20 mA. Digital process variable is superimposed on 4-20 mA signal, and available to any host that conforms to the HART protocol. The digital HART® signal can be used in multidrop mode.

The default output is HART Revision 7. To order HART Revision 5 factory configured, add option code HR5. The device can also be field configured to HART Revision 5 if needed.

Signal wiring

Recommended output cabling is twisted shielded pairs, 24-12 AWG.

Rosemount 333 HART® Tri-Loop™

By sending the digital HART signal to the optional HART Tri-Loop, it is possible to have up to three additional 4–20 mA analog signals.



See the Rosemount 333 HART Tri-Loop [Product Data Sheet](#) for additional information.

Emerson Wireless 775 THUM™ Adapter

The optional Emerson Wireless 775 THUM Adapter can be mounted directly on the transmitter or by using a remote mounting kit.



IEC 62591 (*WirelessHART®*) enables access to multivariable data and diagnostics, and adds wireless to almost any measurement point.

See the Emerson Wireless 775 THUM Adapter [Product Data Sheet](#) and [Technical Note](#) for additional information.

Power requirements

Terminals in the transmitter housing provide connections for signal cables. The Rosemount 5300 Level Transmitter is loop-powered and operates with the following power supplies:

Table 6: External Power Supply for HART

Approval type	Input voltage (U_i) ⁽¹⁾
None	16 - 42.4 Vdc
Non-sparking/Energy Limited	16 - 42.4 Vdc
Intrinsically Safe	16 - 30 Vdc
Explosion-proof/Flameproof	20 - 42.4 Vdc

(1) Reverse polarity protection.

Figure 12: External Power Supply for HART

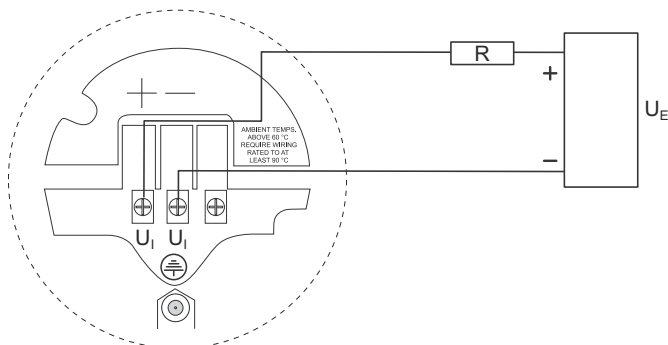

R = Load Resistance (Ω)

U_E = External Power Supply Voltage (Vdc)

U_i = Input Voltage (Vdc)

For Explosion-proof/Flameproof installations the Rosemount 5300 Level Transmitters have a built-in barrier; no external barrier needed.⁽⁷⁾

When a THUM Adapter is fitted, it adds a maximum drop of 2.5 Vdc in the connected loop.

Table 7: Minimum Input Voltage (U_i) at Different Currents

Hazardous approval	Current	
	3.75 mA	21.75 mA
	Minimum input voltage (U _i)	
Non-hazardous installations, intrinsically safe installations and Non-sparking installations	16 Vdc	11 Vdc
Explosion-proof/flameproof installations	20 Vdc	15.5 Vdc

Signal on alarm

	High	Low
Standard	21.75 mA	3.75 mA
Namur NE43	22.50 mA	3.60 mA

Saturation levels

	High	Low
Standard	20.8 mA	3.9 mA
Namur NE43	20.5 mA	3.8 mA

FOUNDATION™ Fieldbus

Power requirements

Terminals in the transmitter housing provide connections for signal cables. The Rosemount 5300 Level Transmitter is powered over FOUNDATION™ Fieldbus with standard fieldbus power supplies. The transmitter operates with the following power supplies:

Table 8: External Power Supply for FOUNDATION Fieldbus

Approval type	Power supply (Vdc)
None	9 - 32
Non-sparking/Energy limited	9 - 32
Intrinsically Safe	9 - 30
FISCO	9 - 17.5
Explosion-proof/flameproof	16 - 32

For Explosion-proof/Flameproof installations the Rosemount 5300 Level Transmitters have a built-in barrier; no external barrier needed.⁽⁸⁾

Quiescent current draw

22 mA

(7) An external galvanic isolator is always recommended to be used for Flameproof/ Explosion-proof installations.

(8) An external galvanic isolator is always recommended to be used for Flameproof/ Explosion-proof installations.

Blocks and execution time

Block	Execution time
1 Resource	N/A
3 Transducer	N/A
6 Analog Input (AI)	10 ms
1 Proportional/Integrate/Derivate (PID)	15 ms
1 Signal Characterizer (SGCR)	10 ms
1 Integrator (INT)	10 ms
1 Arithmetic (ARTH)	10 ms
1 Input Selector (ISEL)	10 ms
1 Control Selector (CS)	10 ms
1 Output Splitter (OS)	10 ms

FOUNDATION Fieldbus class (basic or Link Master)

Link Master (LAS)

Number of available VCRs

Maximum 20, including one fixed

FOUNDATION Fieldbus instantiation

Yes

Conforming FOUNDATION™ Fieldbus

ITK 6.0.1

FOUNDATION Fieldbus alerts

- Field diagnostics alerts
- Plantweb™ Insight alerts

Modbus®

Output

The RS-485 Modbus version communicates by Modbus RTU, Modbus ASCII, and Levelmaster protocols.

8 data bits, 1 start bit, 1 stop bit, and software selectable parity.

Baud Rate 1200, 2400, 4800, 9600 (default), and 19200 bits/s

Address Range 1 to 255 (default device address is 246)

HART communication is used for configuration via the HART terminals or tunneling via the RS-485.

External power supply

The input voltage U_i for Modbus is 8-30 Vdc (max. rating).

Wiring diagram

Figure 13: Wiring Diagram for RS-485 with Modbus®

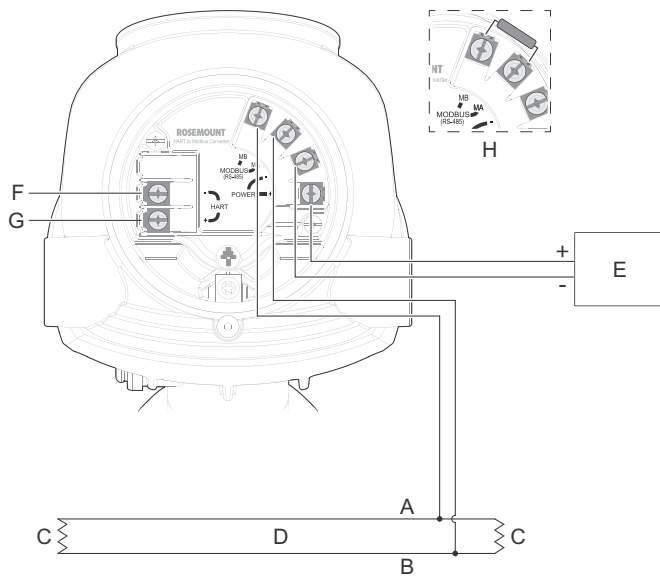

- A. "A" line
- B. "B" line
- C. 120 Ω
- D. RS-485 Bus
- E. Power supply
- F. HART -
- G. HART +
- H. If it is the last transmitter on the bus, connect the 120 Ω termination resistor.

Note

Rosemount 5300 Level Transmitters with Flameproof/Explosion-proof output have a built-in barrier; no external barrier needed.⁽⁹⁾

Power consumption

- < 0.5 W (with HART address=1)
- < 1.2 W (incl. four HART slaves)

Note

The Rosemount 5300 Level Transmitter with Modbus protocol is configured to HART address 1 at factory. This reduces power consumption by locking the analog output at 4 mA.

Display and configuration

Integral display

The integral digital display can toggle between: level, distance, volume, internal temperature, interface distance, interface level, peak amplitudes, interface thickness, percentage of range, analog current out.

Note

The display cannot be used for configuration purposes.

⁽⁹⁾ An external galvanic isolator is always recommended to be used for Flameproof/Explosion-proof installations.

Remote display

Data can be read remotely using the Rosemount 751 Field Signal Indicator for 4-20 mA / HART® (see [Product Data Sheet](#)), or the Rosemount 752 Remote Indicator for FOUNDATION™ Fieldbus (see [Product Data Sheet](#)).

Configuration tools

- Rosemount Radar Master (included in the delivery)
- Device Descriptor (DD) based systems, e.g. AMS Device Manager, handheld communicator, and DeltaV™
- Device Type Manager (DTM™) based systems (compliant with version 1.2 of the FDT®/DTM specification), supporting configuration in for instance Yokogawa Fieldmate/PRM, E+H FieldCare®, and PACTware™

Output units

- Level, Interface and Distance: ft., in., m, cm, or mm
- Level Rate: ft./s, m/s, in./min, m/h
- Volume: ft.³, in.³, US gals, Imp gals, barrels, yd³, m³, or liters
- Temperature: °F and °C

Output variables

Table 9: Output Variables

Variable	5301	5302	5303	PV, SV, TV, QV
Level	✓	✓	✓	✓
Distance to Level (Ullage)	✓	✓	✓	✓
Level Rate	✓	✓	✓	✓
Signal Strength	✓	✓	✓	✓
Volume	✓	✓	✓	✓
Internal Temperature	✓	✓	✓	✓
Interface Level	(✓) ⁽¹⁾	✓	N/A	✓
Interface Distance	(✓) ⁽¹⁾	✓	N/A	✓
Interface Level Rate	(✓) ⁽¹⁾	✓	N/A	✓
Interface Signal Strength	(✓) ⁽¹⁾	✓	N/A	✓
Upper Layer Thickness	(✓) ⁽¹⁾	✓	N/A	✓
Lower Volume	(✓) ⁽¹⁾	✓	N/A	✓
Upper Volume	(✓) ⁽¹⁾	✓	N/A	✓
Signal Quality	✓	✓	✓	(✓) ⁽²⁾
Surface/Noise Margin	✓	✓	✓	(✓) ⁽²⁾
Vapor DC	✓	N/A	N/A	(✓) ⁽²⁾
Analog Output Current ⁽³⁾⁽⁴⁾	✓	✓	✓	N/A
% of Range ⁽⁴⁾	✓	✓	✓	N/A

(1) Interface measurement only for fully submerged probe.
 (2) Not available as primary variable.
 (3) Not available for FOUNDATION™ Fieldbus, Modbus® Signal Output, or for HART® units in fixed current mode.
 (4) LCD display variable only.

Damping

0-60 s (2 s, default value)

Diagnostics

General

Transmitter diagnostics with alerts include hardware and software errors, electronics temperature, probe missing, and invalid measurement and configuration error diagnostics. In addition to this, echo curve and variable logging including signal strength facilitate easy on-line troubleshooting.

Alerts

The transmitter is compliant with NAMUR NE 107 Field Diagnostics for standardized device diagnostic information (only available for FOUNDATION™ Fieldbus or HART®).

Diagnostics Suite

Signal Quality Metrics

Diagnostics package that monitors the relations between surface, noise and threshold. The function can be used to detect abnormal conditions in the process such as probe contamination or sudden loss of signal strength. Signal Quality Metrics parameters are available as Output Variables in Rosemount Radar Master, and can be sent to Distributed Control System (DCS) to trigger an alarm.

Verification reflector

The reflector, which is available with single lead flexible probes, is used to test and continuously verify that the transmitter is functioning properly in both tank and chamber/pipe installations. Compared to traditional diagnostics that only monitor the transmitter electronics, the reflector can also be used to diagnose the upper parts of the probe inside the tank for e.g. build-up, corrosion monitoring and other process related conditions.

Figure 14: Verification Reflector

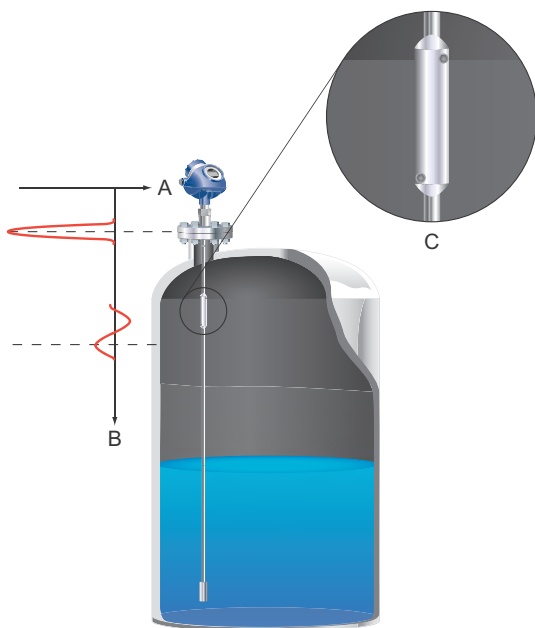

- A. Amplitude
- B. Distance
- C. Reflector

The primary use-cases for the reflector are:

- Verification of transmitter and probe (i.e. proof-testing)
- High level supervision (i.e. continuous monitoring of high level condition)

Verification

During commissioning, the location and amplitude characteristics of the reflector are stored in the transmitter. When the test procedure is later initiated, the stored reflector data is compared to the current measurement to verify the integrity of the measurement electronics and upper part of the probe.

During the test, the transmitter will output a level corresponding to the reflector position, which can be used to verify the integrity of the transmitter output.

High level supervision

Additionally, the reflector's unique echo characteristics aid the transmitter to locate a liquid surface above the reflector, thereby offering increased reliability to detect high level conditions at a user selectable limit.

The transmitter continuously monitors the status of the reflector and abnormal conditions generate alarms and alerts as appropriate.

Limitations for verification reflector

Application	Not to be used in fully submerged applications
Minimum dielectric constant	2.4 (for option code HL1) 2.0 (for option codes HL2 and HL3)

More information

For more information and installation requirements, refer to the High Level Supervision [Manual Supplement](#).

Process temperature and pressure rating

[Process Temperature and Pressure - Max Rating](#) gives the maximum process temperature (measured at the lower part of the flange or threaded connection) and pressure rating for the different tank connections.

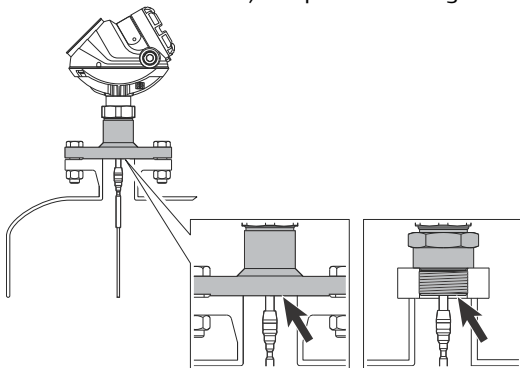

For standard tank connection, final rating may be lower depending on flange, material of construction, and O-ring selection. [Table 10](#) gives the temperature ranges for standard tank seals with different O-ring materials.

Table 10: Temperature and Pressure Ranges for Standard Tank Seals with Different O-ring Material

O-ring material	Temperature °F (°C) in air		Pressure psig (bar)
	Minimum ⁽¹⁾	Maximum	Maximum
Fluoroelastomer (FKM)	-22 (-30)	302 (150)	754 (52)
Ethylene Propylene (EPDM)	-40 (-40)	266 (130)	754 (52)
Kalrez® Perfluoroelastomer (FFKM)	14 (-10)	302 (150)	754 (52)
Nitrile Butadiene (NBR)	-31 (-35)	230 (110)	580 (40)
Fluorosilicone (FVMQ)	-49 (-45)	302 (150)	754 (52)

(1) The O-ring can be stored at lower temperatures (refer to [Table 11](#)).

Note

Always check the chemical compatibility of the O-ring material with your application. If the O-ring material is not compatible with its chemical environment, the O-ring may eventually malfunction.

No wetted O-rings are used in the HTHP, HP, and C versions. Final rating may be lower depending on flange and material of construction selection.

Process Temperature and Pressure - Max Rating

Figure 15: Standard Tank Connection (Code S)

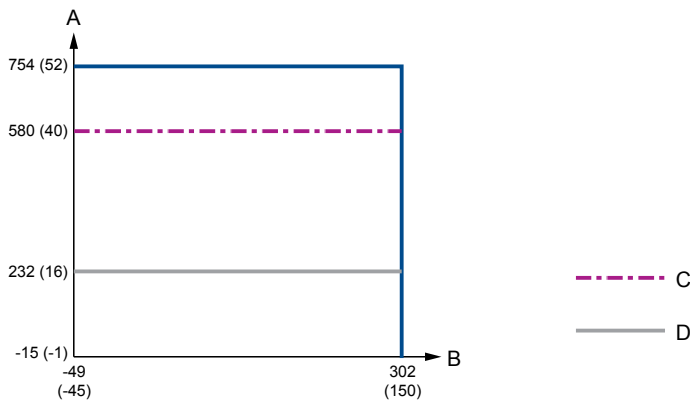

- A. Pressure psig (bar)
- B. Temperature °F (°C)
- C. O-ring material code B (Nitrile Butadiene)
Country certification code J7 (Indian Boiler Regulation)
Overfill prevention code U1 (Overfill prevention according to WHG/TUV)
Protective plate: Alloy C-276 (Material of construction code 2) or Alloy 400 (Material of construction code 3)
- D. Protective plate: PTFE (Material of construction code 7)

Figure 16: HTHP - High Temperature and High Pressure Tank Connection (Code H)

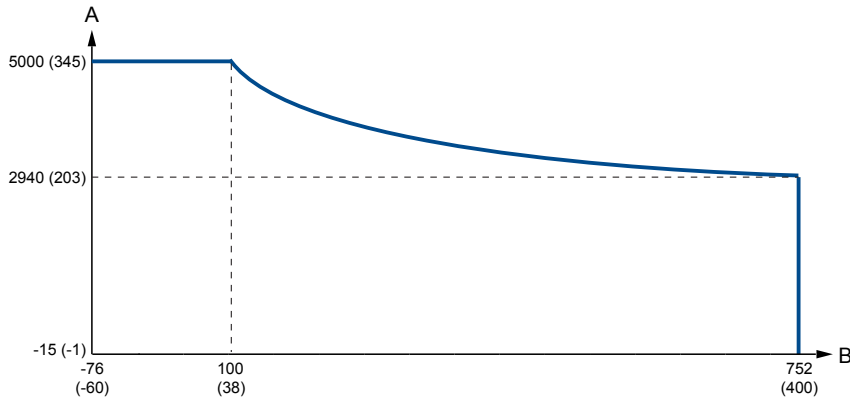

- A. Pressure psig (bar)
- B. Temperature °F (°C)

Figure 17: HP - High Pressure Tank Connection (Code P)

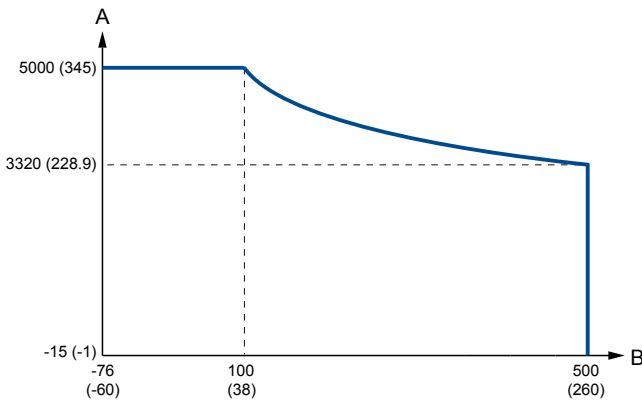

- A. Pressure psig (bar)
- B. Temperature °F (°C)

Figure 18: C - Cryogenic Temperature Tank Connection (Code C)

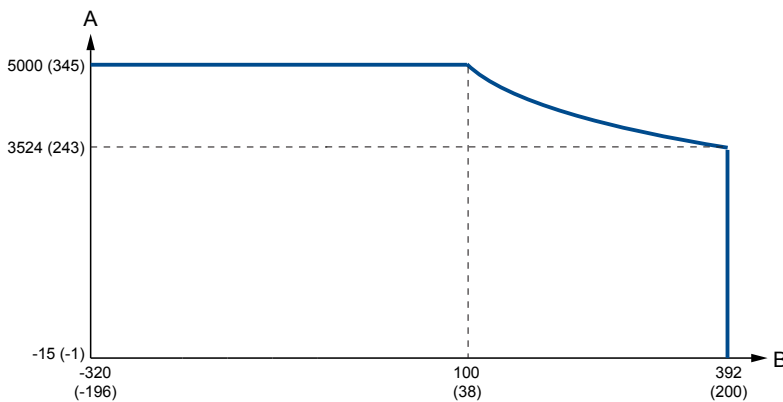

- A. Pressure psig (bar)
- B. Temperature °F (°C)

Temperature limits

The maximum and minimum ambient temperature for the electronics depends on the process temperature (as described by [Figure 19](#) and [Figure 20](#)) and on the approval (see [Product certifications](#)).

Figure 19: Ambient Temperature vs. Process Temperature

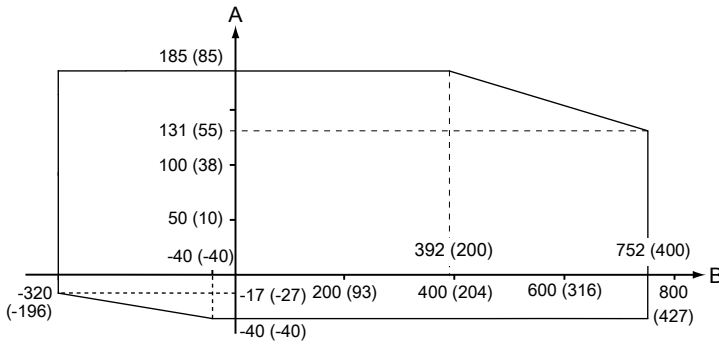

- A. Ambient temperature °F (°C)
- B. Process temperature °F (°C)

For additional information, refer to [Table 11](#).

Figure 20: Ambient Temperature vs. Process Temperature with Option Code BR5

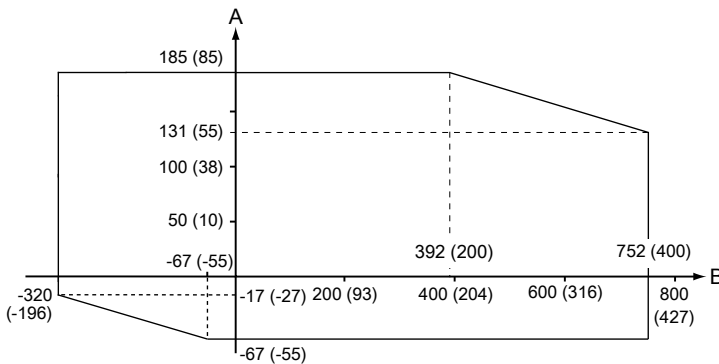

- A. Ambient temperature °F (°C)
- B. Process temperature °F (°C)

Note

Nozzle insulation for the HTHP version (Operating Temperature and Pressure code H) should not exceed 4 in. (10 cm) of height above the flange.

Note

In applications where the ambient temperature exceeds the limits of the electronics, a Remote Mounting connection can be used. The maximum temperature for the Remote Mounting connection at the vessel connection point is 302 °F (150 °C).

The heat sink installation option is mandatory for flanges Class 2500/PN250 or higher in Dynamic Vapor Compensation applications. For flanges Class 1500/PN160 the heat sink option is highly recommended.

Table 11: Ambient Temperature Limits

Description	Operating limit	Storage limit
Without integral display	-40 °F to 185 °F (-40 °C to 85 °C) ⁽¹⁾	-58 °F to 194 °F (-50 °C to 90 °C)
With integral display	-40 °F to 158 °F (-40 °C to 70 °C) ⁽¹⁾⁽²⁾	-40 °F to 185 °F (-40 °C to 85 °C)
Option code BR5 without integral display	-67 °F to 185 °F (-55 °C to 85 °C)	-76 °F to 194 °F (-60 °C to 90 °C)
Option code BR5 with integral display	-67 °F to 158 °F (-55 °C to 70 °C) ⁽²⁾	-76 °F to 185 °F (-60 °C to 85 °C)

(1) Certain model codes supplied to Asia-Pacific region have a minimum temperature of -4 °F (-20 °C). Consult factory if operation at ambient temperature -40 °F (-40 °C) is required.

(2) Integral display may not be readable and device display updates will be slower at temperatures below -4 °F (-20 °C).

Flange rating

ASME flange rating

316 up to Class 1500 flanges according to ASME B16.5 Table 2-2.2 and 316L for Class 2500 flanges according to ASME B16.5 Table 2-2.3:

- Standard: Maximum 302 °F/754 psig (150 °C/52 Bar)
- HP: Class 2500 up to maximum 500 °F (260 °C)
- C: Class 2500 up to maximum 392 °F (200 °C)
- HTHP: Class 2500 up to maximum 752 °F (400 °C)

Alloy C-276 (UNS N10276) according to ASME B16.5 Table 2-3.8:

- Standard: Maximum 302 °F/754 psig (150 °C/52 Bar)
- HP: Class 1500 up to maximum 500 °F (260 °C)
- HTHP: Class 1500 up to maximum 752 °F (400 °C)

Alloy 825 (UNS N08825) according to ASME B16.5 Table 2-3.8:

- Standard: Maximum 302 °F/754 psig (150 °C/52 Bar)
- HP: Class 1500 up to maximum 500 °F (260 °C)
- HTHP: Class 1500 up to maximum 752 °F (400 °C)

Duplex 2205 (UNS S31803) according to ASME B16.5 Table 2-2.8:

- Standard: Maximum 302 °F/754 psig (150 °C/52 Bar)
- HP: Class 1500, -51 °F (-46 °C) up to maximum 500 °F (260 °C)
- HTHP: Class 1500, -51 °F (-46 °C) up to maximum 599 °F (315 °C)

EN flange rating

EN 1.4404 according to EN 1092-1 material group 13E0:

- Standard: Maximum 302 °F/754 psig (150 °C/52 Bar)
- HP: PN 320 up to maximum 500 °F (260 °C)
- C: PN 320 up to maximum 392 °F (200 °C)
- HTHP: PN 320 up to maximum 752 °F (400 °C)

Alloy C-276 (UNS N10276) according to EN 1092-1 material group 12E0:

- Standard: Maximum 302 °F/754 psig (150 °C/52 Bar)

- HP: PN 320 up to maximum 500 °F (260 °C)
- HTHP: PN 320 up to maximum 752 °F (400 °C)

Duplex 2205 (EN 1.4462) according to EN 1092-1 material group 16E0:

- Standard: Maximum 754 psig (52 Bar), -22 °F (-30 °C) up to maximum 302 °F (150 °C)⁽¹⁰⁾
- HP: PN 320, -22 °F (-30 °C) up to maximum 482 °F (250 °C)⁽¹⁰⁾
- HTHP: PN 320, -22 °F (-30 °C) up to maximum 482 °F (250 °C)⁽¹⁰⁾

JIS flange rating

316 according to JIS B2220 material group 2.2:

- Standard: Maximum 302 °F/754 psig (150 °C/52 Bar)
- HP: Maximum temperature 260 °C. Final rating depends on flange.
- C: Maximum temperature 200 °C. Final rating depends on flange.
- HTHP: Maximum temperature 400 °C. Final rating depends on flange.

Fisher and Masoneilan flange rating

316 according to ASME B16.5 Table 2-2.2:

- Standard: Maximum 302 °F/754 psig (150 °C/52 Bar)
- HP: Class 600 up to maximum 260 °C
- C: Class 600 up to maximum 200 °C
- HTHP: Class 600 up to maximum 400 °C

Tri Clamp rating

Tri Clamp is available for the standard temperature and pressure seal.

Table 12: Tri Clamp Rating

Size	Maximum pressure ⁽¹⁾
1½-in. (37.5 mm)	232 psig (16 bar)
2-in. (50 mm)	232 psig (16 bar)
3-in. (75 mm)	145 psig (10 bar)
4-in. (100 mm)	145 psig (10 bar)

(1) The final rating depends on the clamp and gasket.

(10) Minimum and maximum temperature limit due to EN13445-2.

Plate design

Certain models of flanged alloy and PTFE covered probes have a tank connection design with a protective flange plate that prevents the backing flange from being exposed to the tank atmosphere. The protective flange plate is manufactured in the same material as the probe. The backing flange is made of 316L/EN 1.4404 for alloy probes, and 316/1.4404 for PTFE covered probes.

Figure 21: Protective Plate

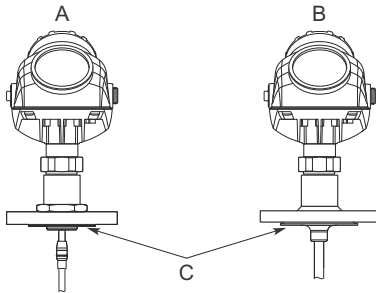

- A. Alloy probe and protective plate
- B. PTFE covered probe and protective plate
- C. Protective plate

PTFE protective plate

Flange rating according to SST backing flange ASME B16.5 Table 2-2.2, EN 1092-1 material group 13E0, and JIS B2220 material group 2.3.

- Standard: Maximum 302 °F/232 psig (150 °C/16 Bar)

Alloy C-276 protective plate

Flange rating according to SST backing flange ASME B16.5 Table 2-2.3, EN 1092-1 material group 13E0, and JIS B2220 material group 2.3.

- Standard: Maximum 302 °F/580 psig (150 °C/40 Bar). Flange plate design is available up to Class 300/PN 40
- HP: Maximum temperature 260 °C. Flange plate design is available up to Class 600/PN 63
- HTHP: Maximum temperature 400 °C. Flange plate design is available up to Class 600/PN 63

Alloy 400 protective plate

Flange rating according to SST backing flange ASME B16.5 Table 2-2.3, EN 1092-1 material group 13E0, and JIS B2220 material group 2.3.

- Standard: Maximum 302 °F/580 psig (150 °C/40 Bar). Flange plate design is available up to Class 300/PN 40

Conditions used for flange strength calculations

See [Table 13](#) to [Table 17](#) for the conditions used for flange strength calculations.

Table 13: 316/316L Flanges

Standard	Bolting material	Gasket		Flange material	Hub material
		Standard/HP/HTHP/C	HP/HTHP/C		
ASME	Stainless steel SA193 B8M Cl.2	Soft (1a) with min. thickness 1.6 mm	Spiral wound gasket with nonmetallic filler (1b)	Stainless steel A182 Gr. F316 and EN 10222-5-1.4404	Stainless steel SA479M 316, and EN 10272-1.4404
EN, JIS	EN 1515-1/-2 group 13E0, A4-70	Soft (EN 1514-1) with min. thickness 1.6 mm	Spiral wound gasket with nonmetallic filler (EN 1514-2)		

Table 14: Process Connection with Plate Design

Standard	Bolting material	Gasket		Flange material	Hub material
		Standard/HP/HTHP/C	HP/HTHP/C		
ASME	Stainless steel SA193 B8M Cl.2	Soft (1a) with min. thickness 1.6 mm	Spiral wound gasket with nonmetallic filler (1b)	Stainless steel A182 Gr. F316L/F316 and EN 10222-5-1.4404	SB574 Gr. N10276 or SB164 Gr. N04400
EN, JIS	EN 1515-1/-2 group 13E0, A4-70	Soft (EN 1514-1) with min. thickness 1.6 mm	Spiral wound gasket with nonmetallic filler (EN 1514-2)		

Table 15: Alloy C-276 Flanges

Standard	Bolting material	Gasket		Flange material	Hub material
		Standard/HP/HTHP	HP/HTHP		
ASME	UNS N10276	Soft (1a) with min. thickness 1.6 mm	Spiral wound gasket with nonmetallic filler (1b)	SB462 Gr. N10276 (solution annealed condition) or SB575 Gr. N10276 (solution annealed condition)	SB574 Gr. N10276
EN		Soft (EN 1514-1) with min. thickness 1.6 mm	Spiral wound gasket with nonmetallic filler (EN 1514-2)		

Table 16: Alloy 825 Flanges

Standard	Bolting material	Gasket		Flange material	Hub material
		Standard/HP/HTHP	HP/HTHP		
ASME	A193 B7 or A320 L7	Soft (1a) with min. thickness 1.6 mm	Spiral wound gasket with nonmetallic filler (1b)	SB564 Gr. N08825 (solution annealed condition)	SB425 Gr. N08825 (solution annealed condition)

Table 17: Duplex 2205 Flanges

Standard	Bolting material	Gasket		Flange material	Hub material
		Standard/HTHP	HP/HTHP		
ASME	A193 B7 or A320 L7	Soft (1a) with min. thickness 1.6 mm	Spiral wound gasket with nonmetallic filler (1b)	Duplex stainless steel SA/A182 F51 and EN10222-5-1.4462	Stainless steel SA479M S31803 and EN 10272-1.4462
EN	Bumax® 88	Soft (EN 1514-1) with min. thickness 1.6 mm	Spiral wound gasket with nonmetallic filler (EN 1514-2)		

Interface measurements

The Rosemount 5302 is a good choice for measuring the interface of oil and water, or other liquids with significant dielectric differences.

It is also possible to measure interface with a Rosemount 5301 in applications where the probe is fully submerged in the liquid, using the submerged probe mode.

Rosemount 5302 with the large coaxial probe provides the ability to continuously keep track of both level and interface level in fully submerged applications. The product level and interface level mode must be selected.

Figure 22: Interface Level Measurement

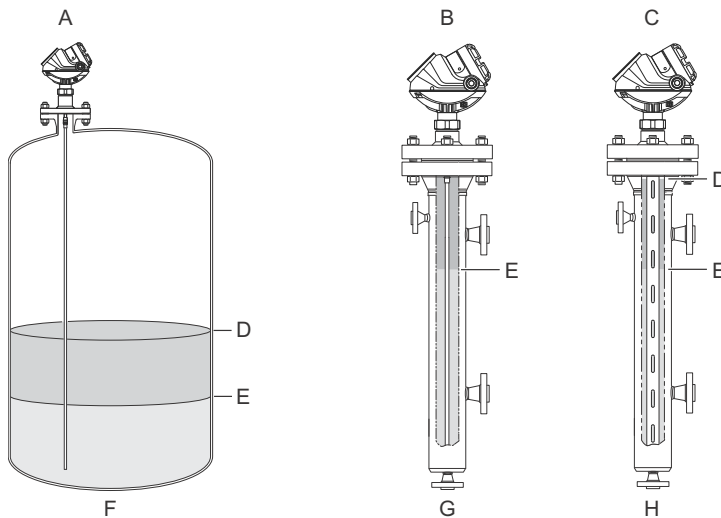

- A. Rosemount 5302
- B. Rosemount 5301
- C. Rosemount 5302 with large coaxial probe
- D. Product level
- E. Interface level
- F. Product level and interface level
- G. Interface level with submerged probe
- H. Product level and interface level with submerged probe

Interface measurement considerations

If interface is to be measured, follow these criteria:

- The dielectric constant of the upper product should be known and should not vary. The Rosemount Radar Master software has a built-in dielectric constant calculator to help the user estimate the upper product dielectric constant.

- The dielectric constant of the upper product must have a lower dielectric constant than the lower product to have a distinct reflection.
- The difference between the dielectric constants for the two products must be larger than 6.
- The maximum dielectric constant for the upper product is 7 for the single lead probes, 10 for the coaxial probes, and 8 for the twin lead probes.

Table 18: Minimum Detectable Upper Product Thickness

Probe type	Minimum Detectable Upper Product Thickness
Large coaxial	1 in. (2.5 cm) ⁽¹⁾
Single lead	2.4 in. (6 cm)
Twin lead	5.1 in. (13 cm)
Coaxial (standard/HP/C)	2.8 in. (7 cm)
Coaxial (HTHP)	8 in. (20 cm)

(1) Depending on application characteristics such as the upper product dielectric constant.

Related information

[Interface measuring range](#)

Emulsion layers

Sometimes there is an emulsion layer (mix of the products) between the two products which can affect interface measurements. For guidelines on emulsion situations, consult your local Emerson representative.

High pressure steam applications

Considerations

Saturated steam under high pressure can influence radar level transmitter measurements. Rosemount 5301 with Dynamic Vapor Compensation will automatically compensate for this and maintain the level accuracy.

- Probe type 3V (for 3- to 4-in. chambers) or 4U (for 2-in. chambers) must be used.
- Mount in a 2-, 3-, or 4-in. bypass chamber with flanges appropriately sized for the pressure and temperature of the application.
- Dynamic Vapor Compensation requires a minimum distance X from the flange to the surface level in order to measure the change in the vapor dielectric constant. If the level rises within this area, the unit switches over to static compensation, using the last known vapor dielectric constant.

Table 19: Minimum Distance X

Reference reflector type		Minimum distance X
Length	Option code	
Short, 14 in. (350 mm)	R1	22 in. (560 mm)
Long, 20 in. (500 mm)	R2	28 in. (710 mm)

Figure 23: Minimum Distance X and Minimum Measuring Span

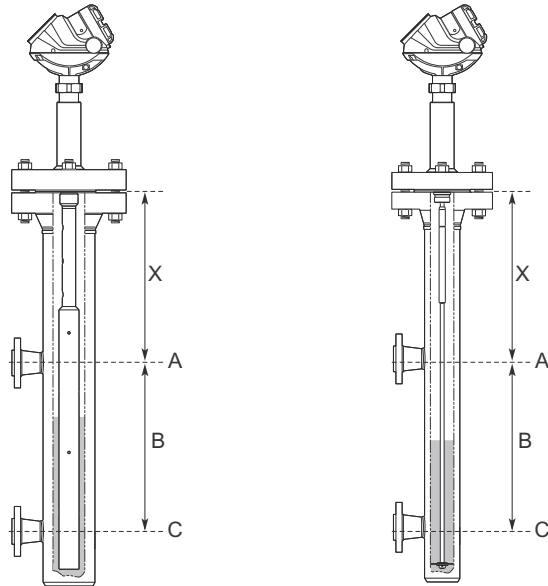

- A. Level: 100%
- B. Minimum measuring span: 12 in. (300 mm)
- C. Level: 0%

- Always ensure there are no disturbances from inlets etc. close to the reference reflector end when using probe type 4U.

Select reference reflector

- The long reflector, 20 in. (500 mm), has the best accuracy and is recommended for all chambers where the dimensions of the chamber allow for it.
- If the distance from the flange to the upper inlet is less than 28 in. (710 mm), the short reflector should be chosen. This distance is a minimum when dynamic compensation is required within the whole measuring range from the lower to the upper inlet. If this is not required, the long reflector can be used and dynamic compensation is possible up to 28 in. (710 mm) from the flange.

For more information, refer to the High Pressure Steam Applications [Technical Note](#).

Physical specifications

Material selection

Emerson provides a variety of Rosemount products with various product options and configurations, including materials of construction that can be expected to perform well in a wide range of applications. The Rosemount product information presented is intended as a guide for the purchaser to make an appropriate selection for the application. It is the purchaser's sole responsibility to make a careful analysis of all process parameters (such as all chemical components, temperature, pressure, flow rate, abrasives, contaminants, etc.), when specifying product, materials, options, and components for the particular application. Emerson is not in a position to evaluate or guarantee the compatibility of the process fluid or other process parameters with the product, options, configuration, or materials of construction selected.

Engineered solutions

When standard model codes are not sufficient to fulfill requirements, please consult the factory to explore possible Engineered Solutions. This is typically, but not exclusively, related to the choice of wetted materials or the design of a process connection. These Engineered Solutions are part of the expanded offerings and may be subject to additional delivery lead time. For ordering, factory will supply a special R-labeled numeric option code that should be added at the end of the standard model string.

Housing and enclosure

Type

- Dual compartment (terminal compartment and the electronics are completely separated).
- Two entries for conduit or cable connections.
- The transmitter housing is separable from probe assembly.
- The transmitter housing can be rotated in any direction.

Electrical connection

½ - 14 NPT for cable glands or conduit entries.

Optional: M20 x 1.5 conduit / cable adapter, M12 4-pin male eurofast® connector or A size Mini 4-pin male minifast® connector.

Recommended output cabling is twisted shielded pairs, 24-12 AWG.

Housing material

Polyurethane-covered Aluminum (Aluminum alloy A360, maximum 0.6 percent Cu), or Stainless Steel Grade CF8M (ASTM A743)

Ingress protection

NEMA® 4X, IP 66, IP67

Factory sealed

Yes

Weight

- Aluminum transmitter head: 4.4 lb (2 kg)
- SST transmitter head: 10.8 lb (4.9 kg)

Remote housing mounting

Kit that includes a flexible armored extension cable and a bracket for wall or pipe mounting.

Figure 24: Remote Housing Mounting

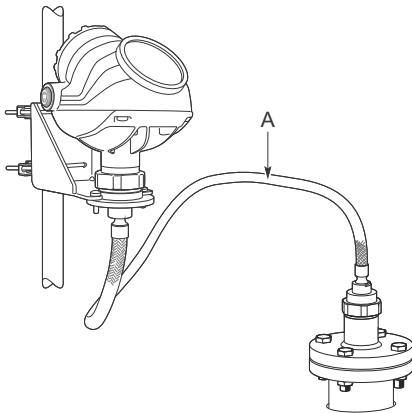

A. Remote Housing Mounting Cable: 3, 6, or 9 ft (1, 2, or 3 m)

Heat sink

The heat sink is used for remote housing mounting to keep the temperature at the vessel connection point at a maximum of 302 °F (150 °C). The heat sink installation option is available for Rosemount 5300 with Dynamic Vapor Compensation (DVC). Heat sink is mandatory for DVC probes with flanges Class 2500/PN250 or higher and highly recommended for Class 1500/PN160.

Figure 25: Heat Sink

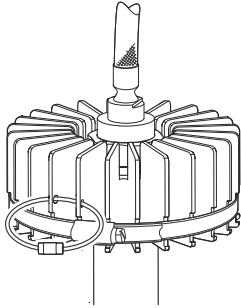

Related information

[Dimensional drawings](#)

Tank connection

The tank connection consists of a tank seal, a flange, Tri Clamp, or NPT or BSPP (G) threads.

Flange dimensions

Follows ASME B16.5, JIS B2220, and EN 1092-1 standards for blind flanges. For Proprietary Fisher™ and Masoneilan™ flanges, see [Proprietary flanges](#).

Vented flanges

Available with Masoneilan and Fisher vented flanges. Vented flanges must be ordered as accessories with a 1½-in. NPT threaded process connection (code RA); see [Proprietary flanges](#). As an alternative to a vented flange, it is possible to use a flushing connection ring on top of the standard nozzle.

Tri Clamp connection

Follows ISO 2852 standard.

Pressure Equipment Directive (PED)

Complies with 2014/68/EU article 4.3

Probes

Probe versions

Coaxial, large coaxial, rigid twin and rigid single lead, segmented rigid single lead, flexible twin and flexible single lead. Probes can be ordered in different materials and options for extreme temperatures and pressure.

For guidelines on which probe to select depending on application, see the Rosemount 5300 [Reference Manual](#).

Total probe length

This is defined from the Upper Reference Point to the end of the probe (weight included, if applicable).

Figure 26: Total Probe Length

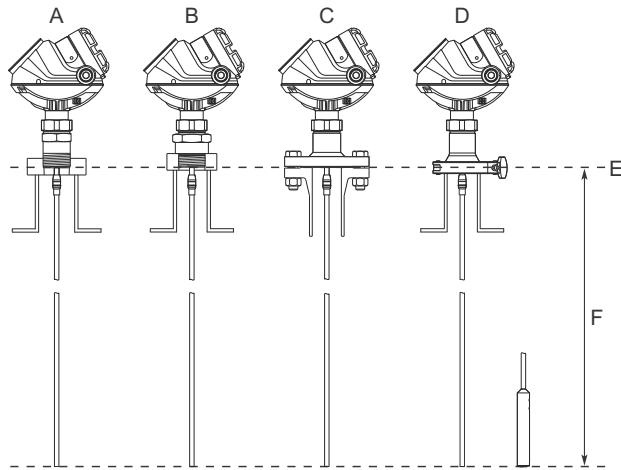

- A. NPT
- B. BSPP (G)
- C. Flange
- D. Tri Clamp
- E. Upper reference point
- F. Total probe length

Select the probe length according to the required measuring range (the probe must be hung and fully extended through the entire distance where level readings are desired).

Cut-to-fit probes

All probes can be cut in field, except for the HTHP coaxial probe and the PTFE covered probe.

However, there are some restrictions for the standard and HP/C coaxial probes: Probes over 4.1 ft. (1.25 m) can be cut up to 2 ft. (0.6 m). Shorter probes can be cut to the minimum length of 1.3 ft. (0.4 m).

Flexible single lead probes can be cut to the minimum length of 3.3 ft. (1.0 m).

Minimum and maximum probe length

Probe type	Probe length
Flexible single lead	3.3 to 164 ft. (1 to 50 m)
Rigid single lead (0.3 in./8 mm)	1.3 to 9.8 ft. (0.4 to 3 m)
Rigid single lead (0.5 in./13 mm)	1.3 to 19.7 ft. (0.4 to 6 m)
Segmented rigid single lead	1.3 to 32.8 ft. (0.4 to 10 m)
Flexible twin lead	3.3 to 164 ft. (1 to 50 m)
Rigid twin lead	1.3 to 9.8 ft. (0.4 to 3 m)
Coaxial	1.3 to 19.7 ft. (0.4 to 6 m)
Large coaxial	1.0 to 19.7 ft. (0.3 to 6 m)

Probe angle

0 to 90 degrees from vertical axis

Note

Models with QT option code should not be installed in angled probe installations.

Tensile strength

- 0.16 in. (4 mm) Flexible single lead SST: 2698 lb (12 kN)
- 0.16 in. (4 mm) Flexible single lead Alloy C-276: 1574 lb (7 kN)
- 0.16 in. (4 mm) Flexible single lead Alloy 825: 1574 lb (7 kN)
- 0.16 in. (4 mm) Flexible single lead Alloy 400: 1124 lb (5 kN)
- 0.16 in. (4 mm) Flexible single lead Duplex 2205: 1349 lb (6 kN)
- 0.24 in. (6 mm) Flexible single lead SST: 6519 lb (29 kN)
- Flexible twin lead SST: 2023 lb (9 kN)

Collapse load

- 0.16 in. (4 mm) Flexible single lead SST: 3597 lb (16 kN)
- 0.16 in. (4 mm) Flexible single lead Alloy C-276: 1798 lb (8 kN)
- 0.16 in. (4 mm) Flexible single lead Alloy 825: 1798 lb (8 kN)
- 0.16 in. (4 mm) Flexible single lead Alloy 400: 1349 lb (6 kN)
- 0.16 in. (4 mm) Flexible single lead Duplex 2205: 1574 lb (7 kN)
- 0.24 in. (6 mm) Flexible Single Lead SST: 7868 lb (35 kN)

Sideway capacity

- Rigid single lead/Segmented rigid single lead: 4.4 ft. lbf, 0.44 lb at 9.8 ft. (6 Nm, 0.2 kg at 3 m)
- Rigid twin lead: 2.2 ft. lbf, 0.22 lb at 9.8 ft. (3 Nm, 0.1 kg at 3 m)
- Coaxial/Large coaxial: 73.7 ft. lbf, 3.7 lb at 19.7 ft. (100 Nm, 1.67 kg at 6 m)

Material exposed to tank atmosphere

Table 20: Standard Probe (Operating Temperature and Pressure Code S)

Material of construction code	Material exposed to tank atmosphere
1 (probe types 6A and 6B)	316L/316 (EN 1.4404) ⁽¹⁾ , Duplex 2507 (UNS S32750/EN 1.4410), PTFE, PFA, silicone grease, and O-ring materials
1 (all other probe types)	316L/316 (EN 1.4404) ⁽¹⁾ , PTFE, PFA, silicone grease, and O-ring materials
2 and H	Alloy C-276 (UNS N10276), PTFE, PFA, silicone grease, and O-ring materials
3	Alloy 400 (UNS N04400), Alloy K500 (UNS N05500), PTFE, PFA, silicone grease, and O-ring materials
7	PTFE (1 mm PTFE cover)
8	316L/316 (EN 1.4404), PTFE, silicone grease, and O-ring materials
D	Duplex 2205 (UNS S31803/EN 1.4462), Duplex 2507 (UNS S32750/EN 1.4410), PTFE, PFA, silicone grease, and O-ring materials
E	Alloy 825 (UNS N08825), PTFE, PFA, silicone grease, and O-ring materials

(1) For flexible single/twin lead probes only.

Table 21: HTHP Probe (Operating Temperature and Pressure Code H)

Material of construction code	Material exposed to tank atmosphere
1 (probe types 3V and 4U)	316L/316 (EN 1.4404), Ceramic (Al ₂ O ₃), Graphite, and Alloy C-276 (UNS N10276)
1 (all other probe types)	316L/316 (EN 1.4404) ⁽¹⁾ , Ceramic (Al ₂ O ₃), Graphite, Alloy C-276 (UNS N10276), and Alloy 718 (UNS N07718)
2 and H	Alloy C-276 (UNS N10276), Ceramic (Al ₂ O ₃), Graphite, and Alloy 718 (UNS N07718)
D	Duplex 2205 (UNS S31803/EN 1.4462), Ceramic (Al ₂ O ₃), Graphite, Alloy C-276 (UNS N10276), and Alloy 718 (UNS N07718)
E	Alloy 825 (UNS N08825), Ceramic (Al ₂ O ₃), Graphite, Alloy C-276 (UNS N10276), and Alloy 718 (UNS N07718)

(1) For flexible single lead probes only.

Table 22: HP Probe (Operating Temperature and Pressure code P)

Material of construction code	Material exposed to tank atmosphere
1 (probe type 3C)	316L/316 (EN 1.4404), Ceramic (Al ₂ O ₃), Graphite, PTFE, and Alloy C-276 (UNS N10276)
1 (all other probe types)	316L/316 (EN 1.4404) ⁽¹⁾ , Ceramic (Al ₂ O ₃), Graphite, PFA, PTFE, Alloy C-276 (UNS N10276), and Alloy 718 (UNS N07718)
2 and H	Alloy C-276 (UNS N10276), Ceramic (Al ₂ O ₃), Graphite, PFA, PTFE, and Alloy 718 (UNS N07718)
D	Duplex 2205 (UNS S31803/EN 1.4462), Ceramic (Al ₂ O ₃), Graphite, PFA, PTFE, Alloy C-276 (UNS N10276), and Alloy 718 (UNS N07718)
E	Alloy 825 (UNS N08825), Ceramic (Al ₂ O ₃), Graphite, PFA, PTFE, Alloy C-276 (UNS N10276), and Alloy 718 (UNS N07718)

(1) For flexible single lead probes only.

Table 23: Cryogenic Probe (Operating Temperature and Pressure code C)

Material of construction code	Material exposed to tank atmosphere
1 (probe type 3C)	316L/316 (EN 1.4404), Ceramic (Al ₂ O ₃), Graphite, PTFE, and Alloy C-276 (UNS N10276)
1 (all other probe types)	316L/316 (EN 1.4404) ⁽¹⁾ , Ceramic (Al ₂ O ₃), Graphite, PFA, PTFE, Alloy C-276 (UNS N10276), and Alloy 718 (UNS N07718)

(1) For flexible single lead probes only.

Weight

Table 24: Flange and Probes

Item	Weight
Flange	Depends on flange size
Flexible single lead probe	0.05 lb/ft. (0.08 kg/m)
Rigid single lead probe (0.3-in./8 mm)	0.27 lb/ft. (0.4 kg/m)
Rigid single lead probe (0.5-in./13 mm)	0.71 lb/ft. (1.06 kg/m)
Segmented rigid single lead probe	0.71 lb/ft. (1.06 kg/m)
Flexible twin lead probe	0.09 lb/ft. (0.14 kg/m)
Rigid twin lead probe	0.40 lb/ft. (0.6 kg/m)
Coaxial probe	0.67 lb/ft. (1 kg/m)
Large coaxial probe	1.48 lb/ft. (2.2 kg/m)

Table 25: End Weight

Item	Weight
Standard weight for flexible single lead probe (0.16-in./4 mm)	0.88 lb (0.40 kg)
Short weight (W2) for flexible single lead probe (0.16-in./4 mm)	0.88 lb (0.40 kg)
Heavy weight (W3) for flexible single lead probe (0.16-in./4 mm)	2.43 lb (1.10 kg)
Weight for flexible single lead probe (0.24-in./6 mm)	1.2 lb (0.55 kg)
Weight for PTFE covered flexible single lead	2.2 lb (1 kg)
Weight for twin lead probe	1.3 lb (0.60 kg)

End weight options

A short weight is available for the single flexible probe. It is used for measuring close to the probe end and shall be used where the measuring range must be maximized. The height is 2 in. (50 mm) and the diameter is 1.5 in. (37.5 mm). The option code is W2.

Installation and mounting considerations

Free space requirement

If the probe is mounted close to a wall, nozzle or other tank obstruction, noise might appear in the level signal. Therefore the following minimum clearance, according to [Table 26](#), must be maintained.

Figure 27: Free Space Requirement

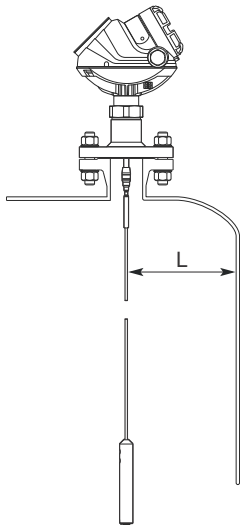

L. Clearance to tank wall

Table 26: Recommended Minimum Free Space for Optimal Performance

Probe type	Condition	Minimum clearance (L)
Rigid single lead/Segmented rigid single lead ⁽¹⁾	Smooth metal tank wall	4 in. (100 mm)
	Disturbing objects such as pipes and beams Plastic, concrete or rugged metal tank wall	16 in. (400 mm) 20 in. (500 mm) ⁽²⁾
Flexible single	Smooth metal tank wall	4 in. (100 mm)
	Disturbing objects such as pipes and beams Plastic, concrete or rugged metal tank wall	20 in. (500 mm)
Coaxial/Large coaxial ⁽¹⁾	N/A	0 in. (0 mm)
Rigid twin lead	N/A	4 in. (100 mm)
Flexible twin	N/A	4 in. (100 mm)

(1) Minimum clearance from tank bottom for the coaxial, large coaxial and rigid single probes is 0.2 in. (5 mm).

(2) Applies to measurements with DC 1.4 or lower.

Flange connection on nozzles

Figure 28: Mounting in Nozzles

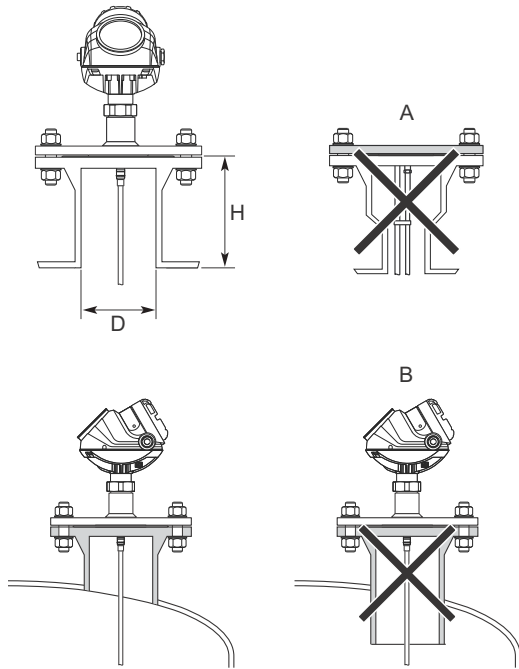

- A. Avoid nozzles with reducer (unless using coaxial probe).
- B. Confirm the nozzle does not extend into the tank.

The transmitter can be mounted in nozzles by using an appropriate flange. It is recommended that the nozzle size is within the dimensions given in [Table 27](#).

Table 27: Nozzle Considerations for Optimal Performance

	Single (rigid/segmented/flexible)	Coaxial/Large coaxial	Twin (rigid/flexible)
Recommended nozzle diameter (D)	6 in. (150 mm)	> probe diameter	4 in. (100 mm)
Minimum nozzle diameter (D) ⁽¹⁾	2 in. (50 mm)	> probe diameter	2 in. (50 mm)
Recommended nozzle height (H) ⁽²⁾	4 in. (100 mm) + nozzle diameter ⁽³⁾	N/A	4 in. (100 mm) + nozzle diameter

- (1) The Trim Near Zone (TNZ) function may be necessary or an Hold Off Distance/Upper Null Zone (UNZ) setup may be required to mask the nozzle.
- (2) Longer nozzles may be used in certain applications. Consult your local Emerson representative for details.
- (3) For nozzles taller than 4 in. (100 mm), the long stud version is recommended (option code LS) to prevent the flexible portion from touching the edge of the nozzle.

Note

The probe must not be in contact with the nozzle (except for the coaxial probe). If the nozzle diameter is less than recommended, the measuring range may be reduced.

Note

For single lead probes, avoid 10-in. (250 mm)/DN250 or larger diameter nozzles, especially in applications with low dielectric constant. An alternative is to install a smaller nozzle inside the nozzle.

Long stud

A long stud is recommended for single flexible probes in a tall nozzle.

Figure 29: A Single Flexible Probe with a Long Stud

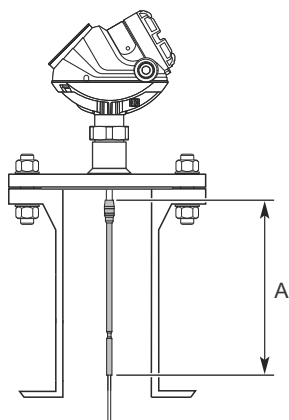

A. Long Stud (9.8 in./250 mm)

Installation in still pipe/chamber

General chamber considerations

Dimensioning the chamber/pipe correctly and selecting the appropriate probe is key to the success in these applications. When selecting a smaller chamber/pipe diameter, such as 2-in., a flexible probe is not suitable due to the chance of it coming into contact with the walls. Also, relatively large side inlets may interfere with the signal.

When gas lift and/or turbulence may occur (e.g. boiling hydrocarbons), a 3- or 4-in. chamber/pipe diameter is recommended for maximum measurement reliability. This is especially true in high pressure and high temperature installations.

Table 28: Recommended and Minimum Chamber/Still Pipe Diameters for Different Probes

Probe type	Recommended diameter	Minimum diameter
Rigid single/segmented rigid single	3 or 4 in. (75 or 100 mm)	2 in. (50 mm)
Flexible single	4 in. (100 mm)	Consult your local Emerson representative
Rigid twin ⁽¹⁾	3 or 4 in. (75 or 100 mm)	2 in. (50 mm)
Flexible twin ⁽¹⁾	4 in. (100 mm)	Consult your local Emerson representative
Coaxial	3 or 4 in. (75 or 100 mm)	1.5 in. (37.5 mm)
Large coaxial	3 or 4 in. (75 or 100 mm)	2 in. (50 mm) ⁽²⁾

(1) The center rod must be placed more than 0.6 in. (15 mm) away from the pipe wall.

(2) Applicable to pipe schedule up to 40s,40. For higher pipe schedule consult your local Emerson representative.

Note

Metal pipes are preferred, especially in applications with low dielectric constant, to avoid disturbances from objects near the pipe.

For more information and installation requirements, refer to the Best Practices for Using Radar in Still Pipes and Chambers [Technical Note](#).

Related information

[Dimensional drawings](#)

Rosemount chamber

A Rosemount chamber allows external mounting of process level instrumentation. It supports a variety of process connections, and optional drain and vent connections. The standard Rosemount chambers are designed according to ASME B31.3. Rosemount chambers compliant with the Pressure Equipment Directive (PED) are available. Customer specific engineered solutions for Rosemount chambers are available upon request. Use option code XC to order together with the Rosemount 5300 Series Transmitters.

Use a centering disc the same diameter as the chamber if the probe length >3.3 ft. (1 m). See [Table 31](#) for which disc to use.

Existing chamber

A Rosemount 5300 Level Transmitter is the perfect replacement in an existing displacer chamber. Proprietary flanges are offered, enabling use of existing chambers to make installation easy.

Figure 30: Existing Displacer Chamber

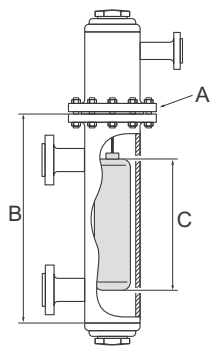

- A. Replace chamber flange
- B. Probe length
- C. Displacer length

Considerations when changing to Rosemount 5300:

- The Rosemount 5300 Level Transmitter flange choice and probe length must be correctly matched to the chamber. Both standard ASME and EN (DIN), as well as proprietary chamber flanges, are available. See [Proprietary flanges](#) to identify the proprietary flanges.
- See [Table 31](#) for guidelines on which disc size to use.
- See [Table 29](#) for guidelines on the required probe length.

Table 29: Required Probe Length in Chambers

Chamber manufacturer	Probe length ⁽¹⁾
Major torque-tube manufacture (249B, 249C, 249K, 249N, 259B)	Displacer + 9 in. (229 mm)
Masoneilan™ (torque tube operated), proprietary flange	Displacer + 8 in. (203 mm)
Other - torque tube ⁽²⁾	Displacer + 8 in. (203 mm)
Magnetrol® (spring operated) ⁽³⁾	Displacer + between 7.8 in. (195 mm) to 15 in. (383 mm)
Others - spring operated ⁽²⁾	Displacer + 19.7 in. (500 mm)

(1) If flushing ring is used, add the ring height to the probe length.
 (2) For other manufacturers, there are small variations. This is an approximate value; actual length should be verified.
 (3) Lengths vary depending on model, SG, and rating, and should be verified.

For additional information, see the Replacing Displacers with Guided Wave Radar [Technical Note](#).

Probe type in chamber considerations

When installing a Rosemount 5300 in a chamber, a large coaxial or a single lead probe is recommended. The large coaxial probe should always be considered first whenever the application and dimensions of the chamber allow for it.

Large coaxial probes are the preferred choice for installation in chambers with limited space above and below the process connections. This type of probe has the best interface resolution and outstanding performance with low dielectric fluids. It is also unaffected by external disturbances such as protruding welds and side taps.

Single rigid probes are suitable for chamber installations. When used in a metal, small diameter pipe, single rigid probes offer a stronger return signal than when used in open applications. This makes them suitable for low dielectric and interface applications. In addition, for applications with highly viscous media where build up is likely to occur, single rigid probes is the best choice.

Single flexible probes may be used in longer bypass chambers, but care must be taken to ensure that the probe is suspended in a true vertical position and does not touch the pipe wall. If flexible probes are to be used, the bypass chambers should be 4 in. (100 mm) or larger in diameter to allow room for some flexing.

The probe must not touch the chamber wall, should extend the full height of the chamber, but not touch the bottom of the chamber. The probe length determines if a single rigid or single flexible probe should be used:

- Less than 19.7 ft. (6.0 m): Rigid single probe is recommended. Use a centering disc for probe > 3.3 ft. (1 m). When mounting space is limited, use a flexible single probe with a weight and centering disc.
- More than 19.7 ft. (6.0 m): Use flexible single probe with a weight and centering disc.⁽¹¹⁾

Centering disc for pipe installations

To prevent the probe from contacting the chamber or pipe wall, centering discs are available for flexible single, rigid single, and flexible twin lead probes. The disc is attached to the end of the probe. Discs are made of stainless steel, Alloy C-276, Alloy 400, Alloy 825, Duplex 2205, or PTFE. The centering disc in PTFE is not available for HTHP probes.

For the segmented rigid single lead probe, up to five PTFE centering discs can be mounted along the probe, but keep a minimum distance of two segments between the discs. Additionally, a disc in SST or PTFE (part number 03300-1655-xxxx) can be attached to the end of the probe.

When mounting a centering disc, it is important that it fits correctly in the chamber/pipe. See [Figure 31](#) for Dimension D. [Table 31](#) shows which centering disc diameter to choose for a particular pipe. [Table 32](#) shows which centering disc diameter to choose for a Rosemount chamber.

Figure 31: Dimension D for Centering Discs

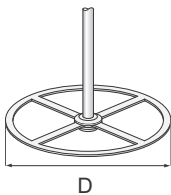

Table 30: Centering Disc Dimensions

Disc size	Actual disc diameter (D)
2-in.	1.8 in. (45 mm)
3-in.	2.7 in. (68 mm)
4-in.	3.6 in. (92 mm)
6-in.	5.55 in. (141 mm)
8-in.	7.40 in. (188 mm)

(11) The Blind Zones and the height of the weight limit the use of single flexible probes shorter than 3 ft. (1 m). If using the flexible probe, the short weight is recommended.

Table 31: Centering Disc Size Recommendation for Different Pipe Schedules

Pipe size	Pipe schedule			
	5s, 5 and 10s, 10	40s, 40 and 80s, 80	120	160
2-in.	2-in.	2-in.	N/A ⁽¹⁾	N/A ⁽²⁾
3-in.	3-in.	3-in.	N/A ⁽¹⁾	2-in.
4-in.	4-in.	4-in.	3-in.	3-in.
5-in.	4-in.	4-in.	4-in.	4-in.
6-in.	6-in.	6-in.	4-in.	4-in.
7-in.	N/A ⁽¹⁾	6-in.	N/A ⁽¹⁾	N/A ⁽¹⁾
8-in.	8-in.	8-in.	6-in.	6-in.

(1) Schedule is not available for pipe size.

(2) No centering disc is available.

Table 32: Centering Disc Size Recommendations for Rosemount Chambers

Chamber size	Chamber rating	Centering disc
3-in.	Up to Class 600/PN 100	3-in.
	Class 900, 1500/PN160, 250	2-in.
3-in. T-piece	Up to Class 600/PN 100	2-in.
4-in.	Up to Class 600/PN 100	4-in.
	Class 900, 1500/PN160, 250	3-in.

Installation in non-metallic tanks and open-air applications

Avoid major sources of electrical disturbance in proximity of the installation (e.g. electrical motors, stirrers, servo mechanisms).

Figure 32: Avoid Electromagnetic Disturbances

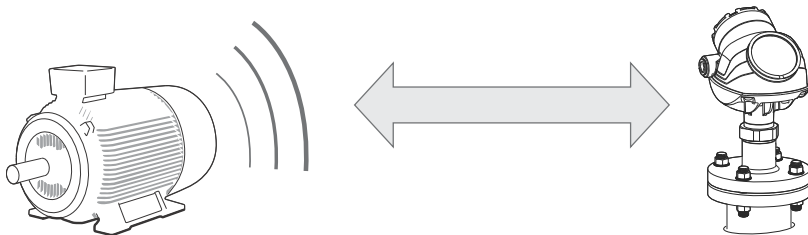

For clean liquids, use a coaxial probe to reduce effect of potential electrical disturbances.

Figure 33: Coaxial Probe in an Open-Air Application

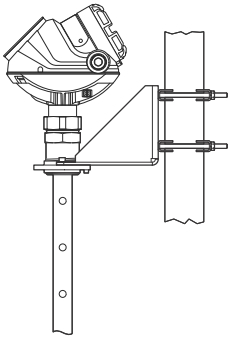

For optimal single lead probe performance in non-metallic tanks, the probe must be mounted with a metal flange, or screwed in to a metal sheet ($d > 14$ in./350 mm) if a threaded version is used.

Figure 34: Mounting in Non-Metallic Tanks

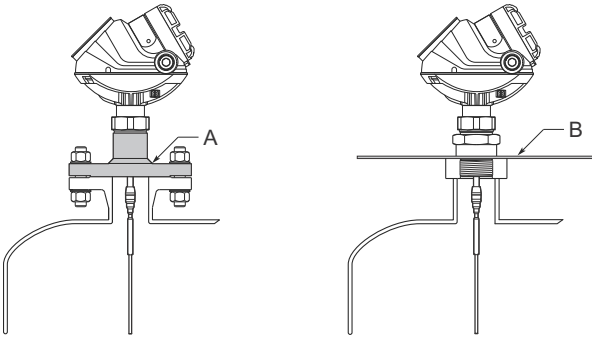

- A. Metal flange
- B. Metal sheet ($d > 14$ in./350 mm)

Minimum distance between two single probes

When installing multiple Rosemount 5300 Level Transmitters with single probes in the same tank, ensure to place the devices at proper distance from each other to avoid the risk of interference caused by cross-talk. Table 33 provides recommended minimum distance between two probes. A coaxial probe or a probe installed in a still pipe will not cause any cross-talk.

Table 33: Minimum Distance between Single Probes

Product	Minimum distance between probes
Oil (DC = 2.1)	5.2 ft. (1.6 m)
Water (DC = 80)	3.3 ft. (1.0 m)

Other mechanical considerations

To get best possible performance, the following must be considered before installing the transmitter:

- Inlets should be kept at a distance in order to avoid product filling on the probe
- Avoid physical contact between probes and agitators, as well as applications with strong fluid movement unless the probe is anchored

- Probe tie-down is recommended if the probe can move to within 1 ft. (30 cm) of any object during operations
- In order to stabilize the probe for side forces, it is possible to fix or guide the probe to the tank bottom

Figure 35: Stabilize the Probe for Side Forces

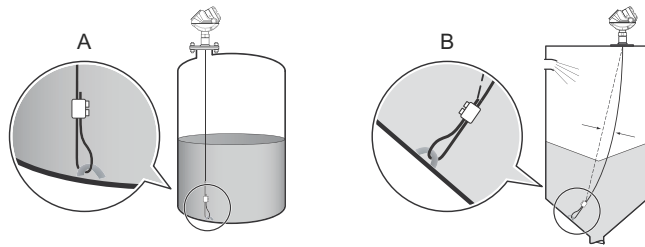

A. Flexible single lead probe with chuck installed in liquids and in solids.

B. For solids, it is recommended that the probe should be slack to prevent high tensile loads.

See the Rosemount 5300 [Reference Manual](#) for more mechanical installation information.

Product certifications

See the Rosemount 5300 [Product Certifications](#) document for detailed information on the existing approvals and certifications.

Dimensional drawings

Figure 36: Rigid Single Lead Probe with Flange Connection

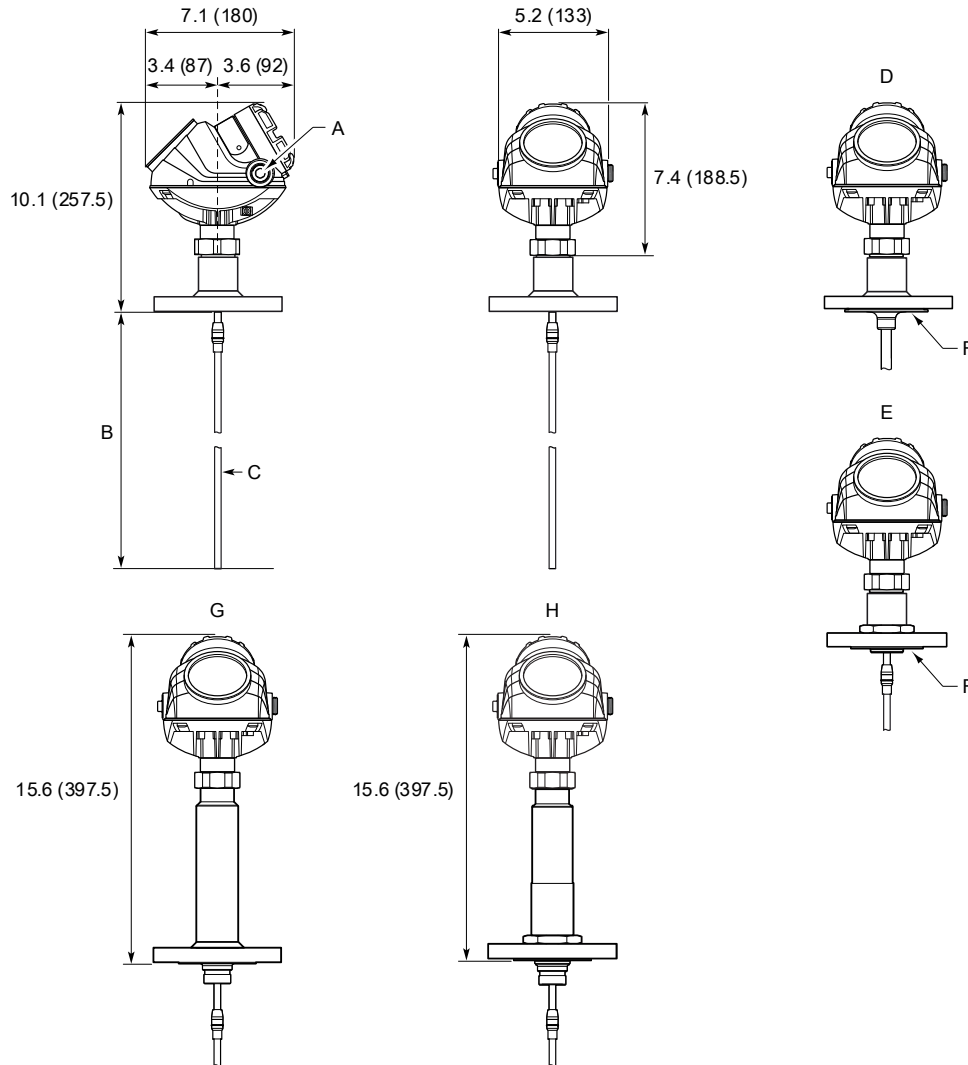

- A. 1/2 - 14 NPT; optional adapters: M20x1.5, eurofast® and minifast®
- B. L ≤ 10 ft. (3 m) for Ø 0.31 (8); L ≤ 20 ft. (6 m) for Ø 0.51 (13)
- C. Ø 0.31 (8); Ø 0.51 (13); Ø 0.47 (12) for PTFE covered probe
- D. PTFE covered probe and protective plate
- E. Alloy probe and protective plate
- F. The PTFE and Alloy probes are designed with a protective plate.
- G. HTHP/HP/C version
- H. HTHP/HP Plate Design (Option for Alloy versions)

Dimensions are in inches (millimeters).

Figure 37: Rigid Single Lead Probe with Tri Clamp Connection

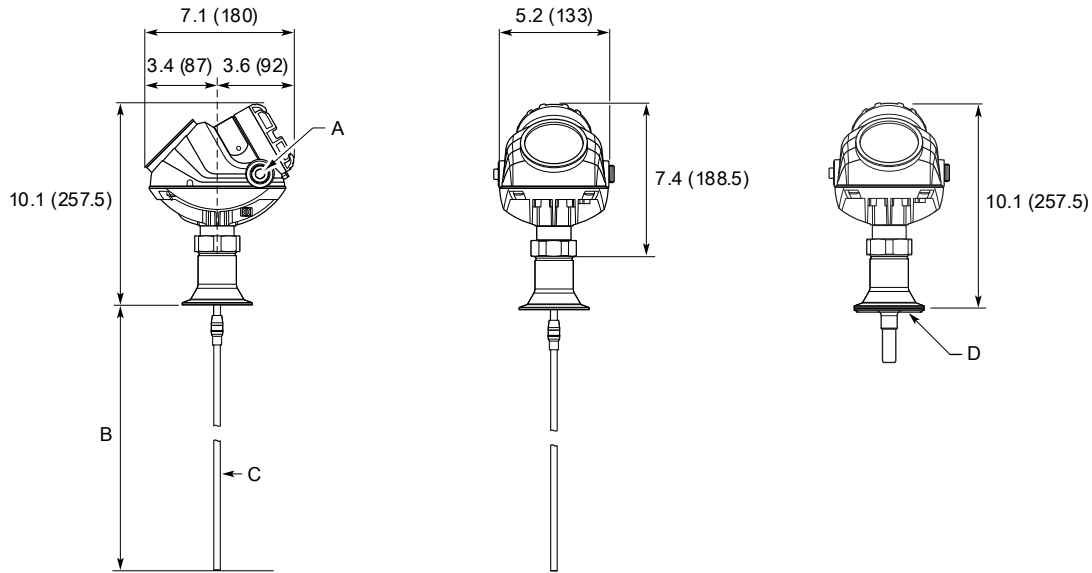

- A. 1/2 - 14 NPT; optional adapters: M20x1.5, eurofast and minifast
- B. L ≤ 10 ft. (3 m) for Ø 0.31 (8); L ≤ 20 ft. (6 m) for Ø 0.51 (13)
- C. Ø 0.31 (8); Ø 0.51 (13); Ø 0.47 (12) for PTFE covered probe
- D. PTFE covered probe and protective plate

Dimensions are in inches (millimeters).

Figure 38: Rigid Single Lead with Threaded Connection

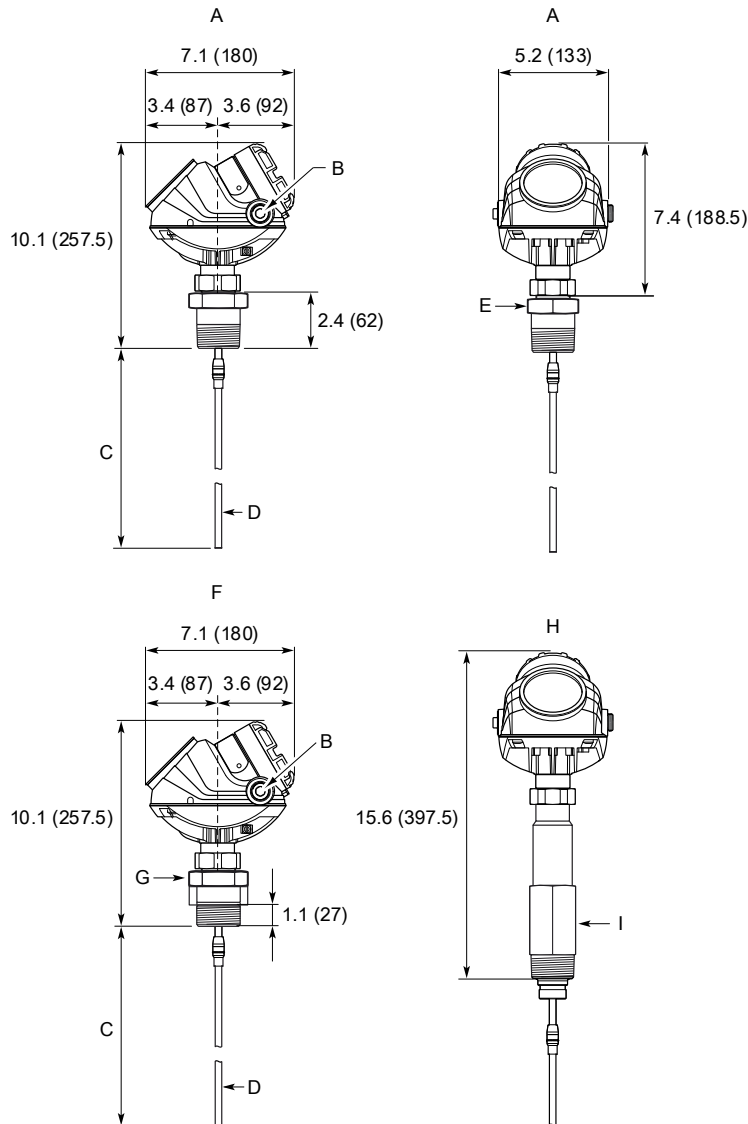

- A. NPT 1 1/2 in.
- B. 1/2 - 14 NPT; optional adapters: M20x1.5, eurofast and minifast
- C. L ≤ 10 ft. (3 m) for Ø 0.31 (8); L ≤ 20 ft. (6 m) for Ø 0.51 (13)
- D. Ø 0.31 (8); Ø 0.51 (13); Ø 0.47 (12) for PTFE covered probe
- E. 1 in. / 1 1/2 in.: s52; 2 in.: s60
- F. G 1 1/2 in.
- G. 1 in.: s52; 1 1/2 in.: s60
- H. NPT 1 1/2, G 1 1/2 in. (HTHP/HP/C version)
- I. NPT: s50; G: s60

Dimensions are in inches (millimeters).

Figure 39: Segmented Rigid Single Lead Probe with Flange Connection

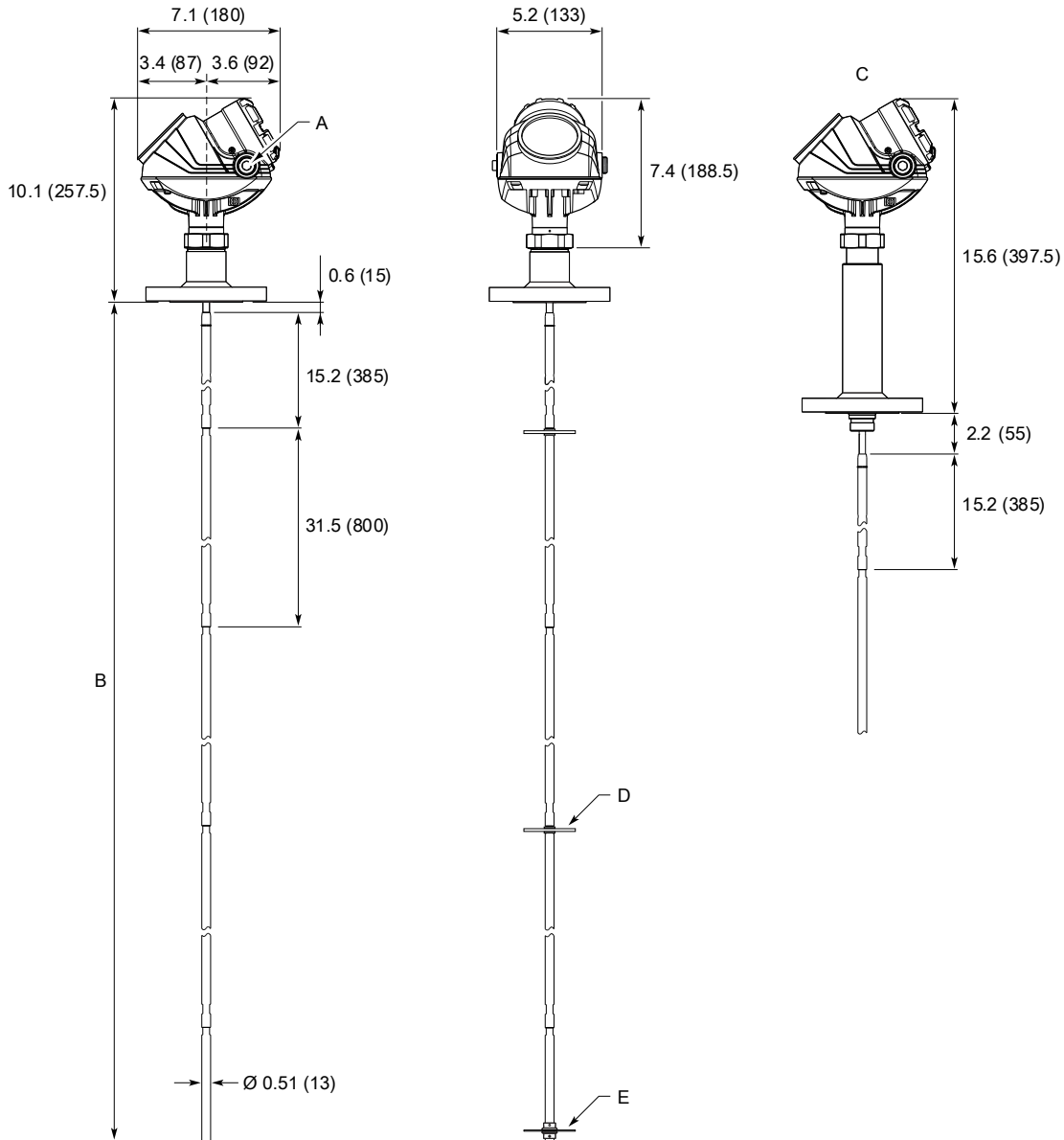

- A. 1/2 - 14 NPT; optional adapters: M20x1.5, eurofast and minifast
- B. L ≤ 33 ft. (10 m)
- C. HTHP/HP/C version
- D. Optional: PTFE centering disc
- E. Optional: Bottom centering disc (SST or PTFE)

Dimensions are in inches (millimeters).

Figure 40: Segmented Rigid Single Lead Probe with Threaded Connection

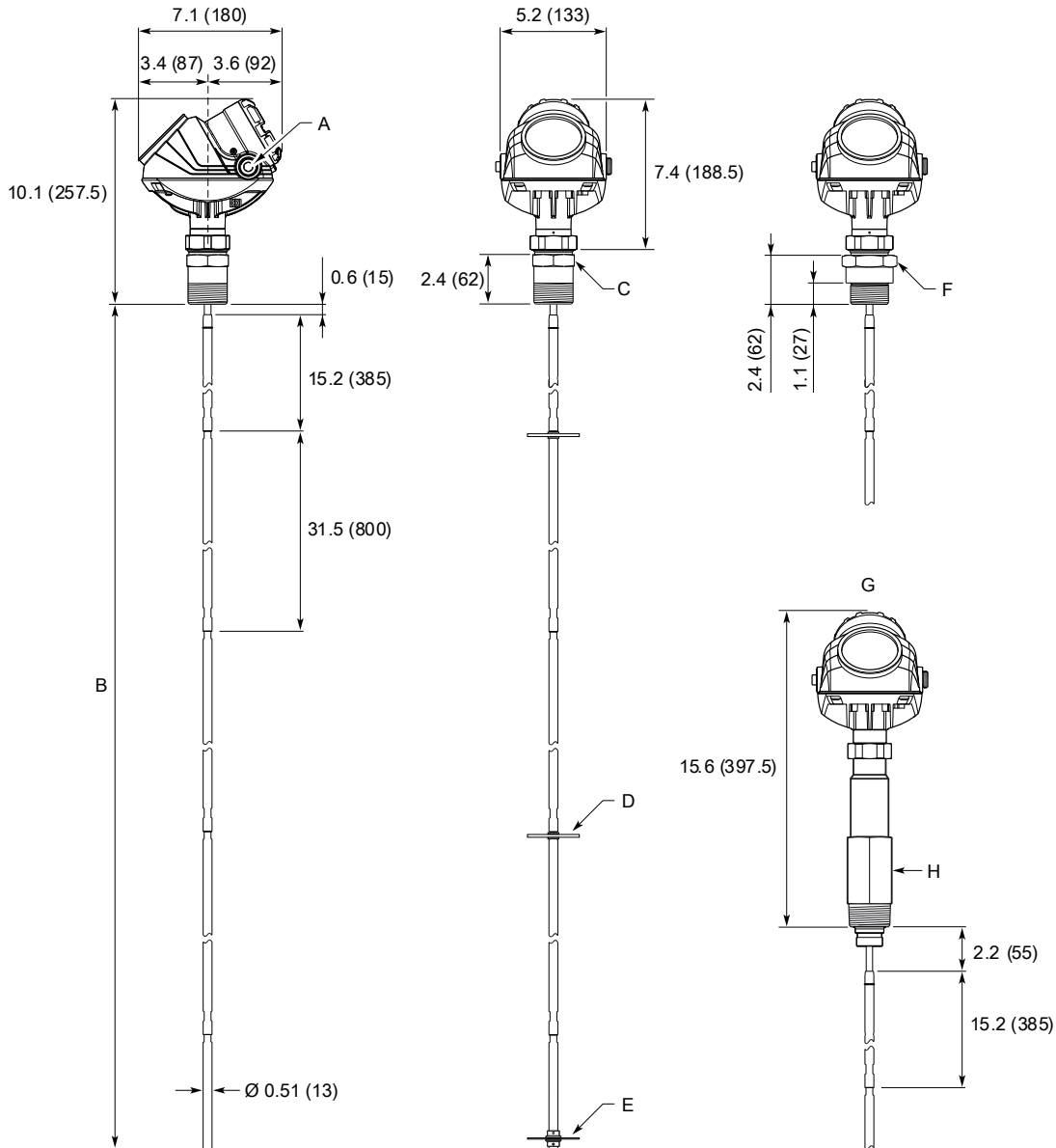

- A. 1/2 - 14 NPT; optional adapters: M20x1.5, eurofast and minifast
- B. $L \leq 33$ ft. (10 m)
- C. NPT 1 in., s52; NPT 1 1/2 in., s52; NPT 2 in., s60
- D. Optional: PTFE centering disc
- E. Optional: Bottom centering disc (SST or PTFE)
- F. BSP-G 1 in., s52; BSP-G 1 1/2 in., s60
- G. HTHP/HP/C version
- H. NPT 1 1/2 in., s50; BSP-G 1 1/2 in., s60

Dimensions are in inches (millimeters).

Figure 41: Single Rigid Vapor Probe for 2-in. Chambers

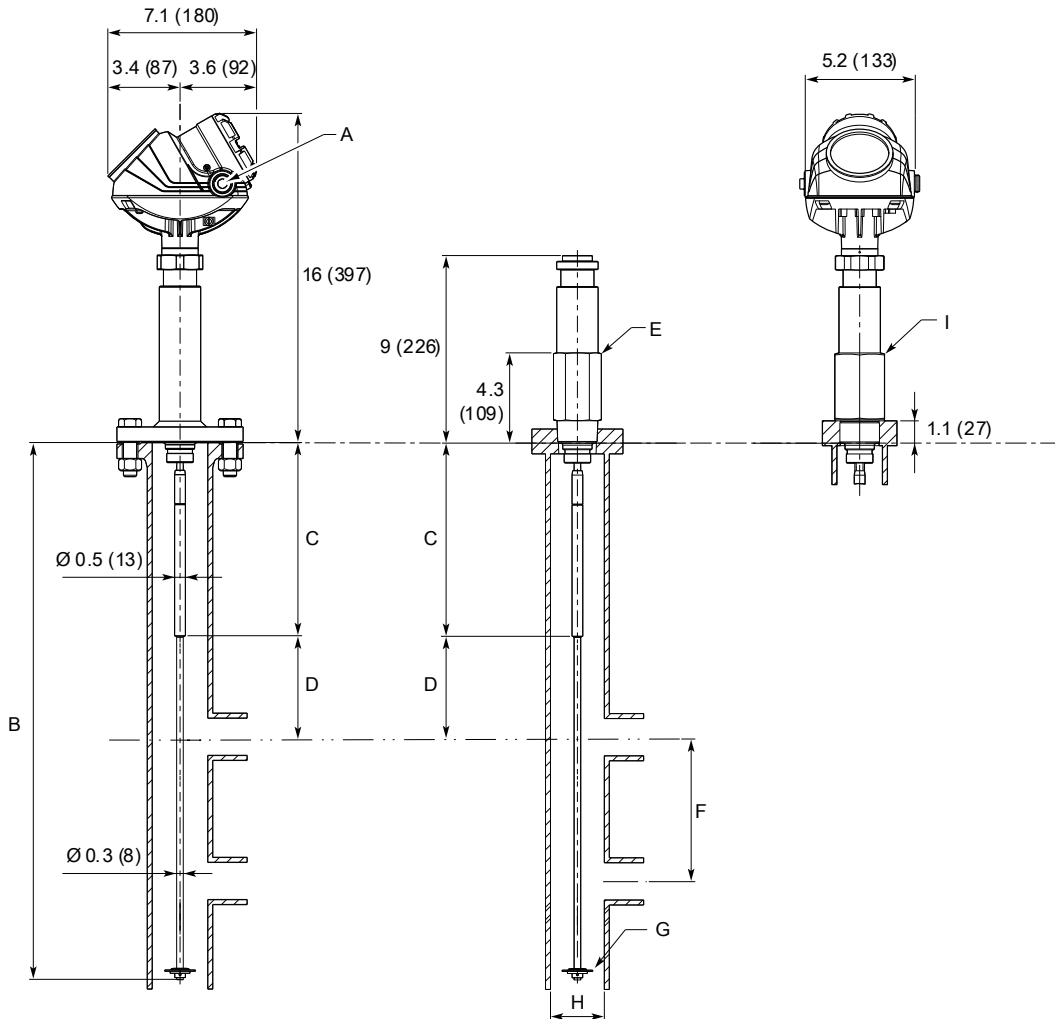

- A. 1/2 - 14 NPT; optional adapters: M20x1.5, eurofast and minifast
- B. L ≤ 10 ft. (3 m)
- C. Short reflector: 13.8 (350); Long reflector: 19.7 (500)
- D. Minimum 8.3 in. (210 mm) distance between water surface and reflector end
- E. NPT 1 1/2 in., s50
- F. Min. 12 in. (300 mm)
- G. 1 1/2-in. centering disc, Ø 1.46 (37)
- H. Pipe inner diameter: Ø 1.5 (38) - Ø 2.05 (52)
- I. BSP-G 1 1/2 in., s60

Dimensions are in inches (millimeters).

Figure 42: Flexible Single Lead Probe with Flange Connection

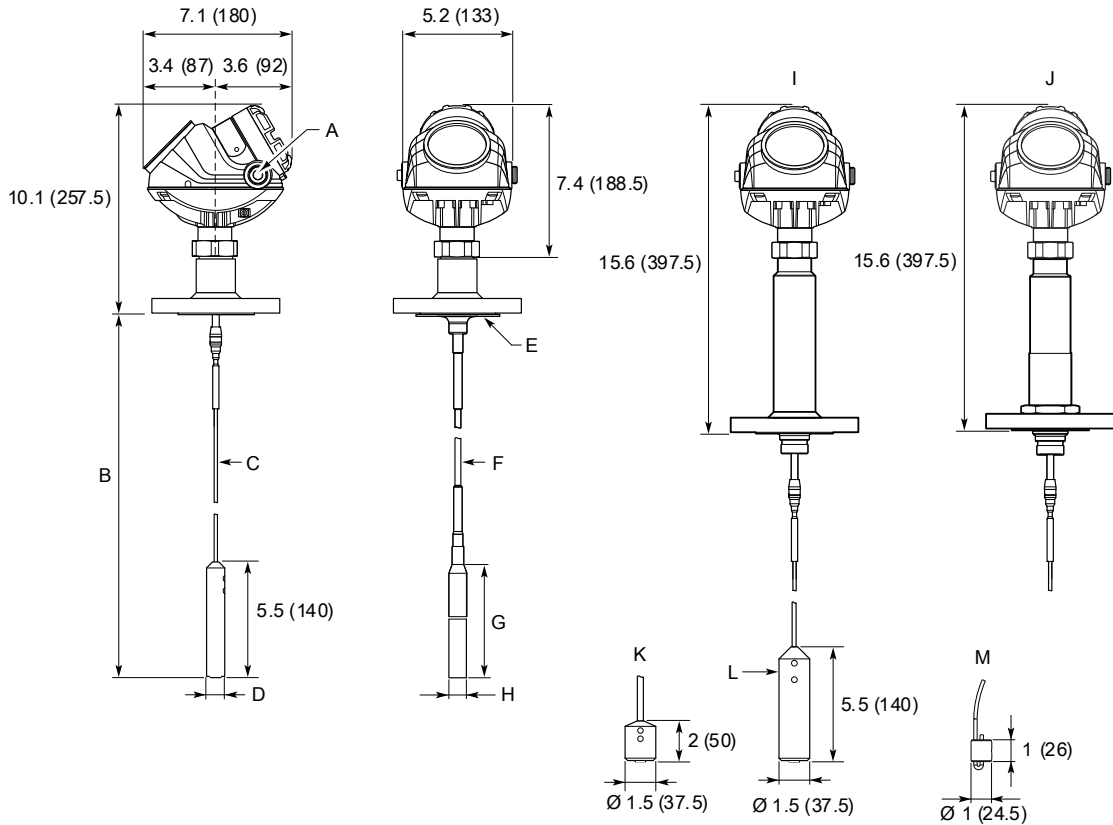

- A. 1/2 - 14 NPT; optional adapters: M20x1.5, eurofast and minifast
- B. L ≤ 164 ft. (50 m)
- C. Ø 0.16 (4); Ø 0.24 (6)
- D. 4 mm probe: Ø 0.86 (22); 6 mm probe: Ø 1.10 (28)
- E. The PTFE covered probe is designed with a protective plate
- F. Ø 0.28 (7) for PTFE covered probe
- G. 17.1 (434) for PTFE covered probe
- H. Ø 0.88 (22.5) for PTFE covered probe
- I. HTHP/HP/C version
- J. HTHP/HP/C Plate Design (Option for Alloy versions)
- K. Short weight (option W2)
- L. Heavy weight (option W3)
- M. Chuck

Dimensions are in inches (millimeters).

Figure 43: Flexible Single Lead Probe with Tri Clamp Connection

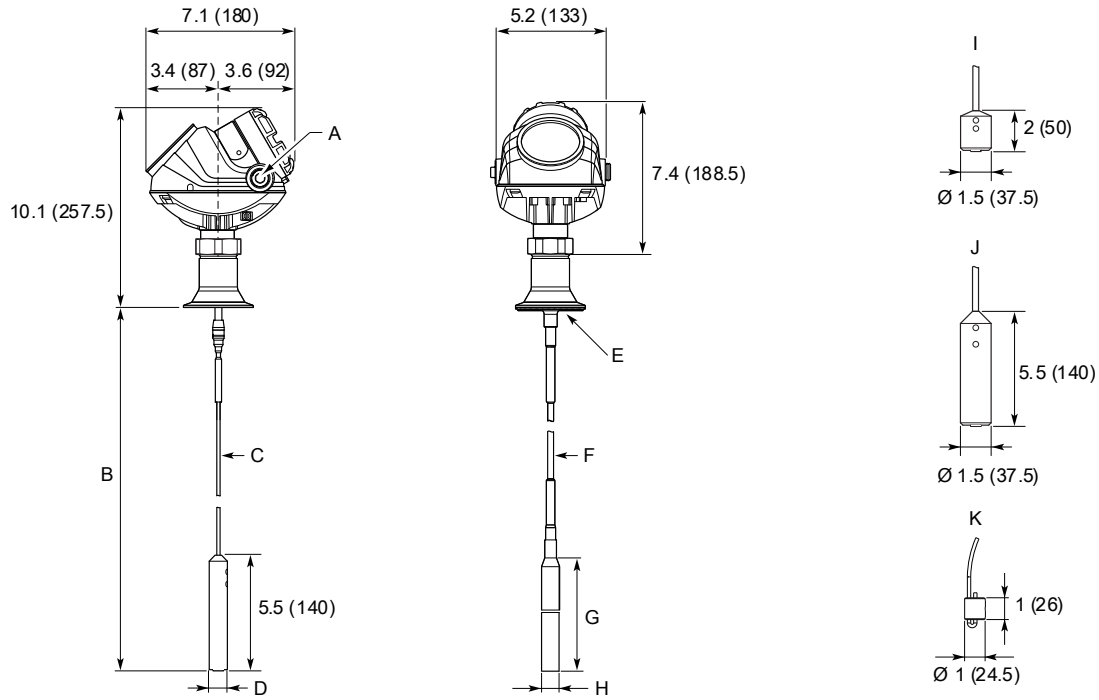

- A. 1/2 - 14 NPT; optional adapters: M20x1.5, eurofast and minifast
- B. $L \leq 164$ ft. (50 m)
- C. $\varnothing 0.16$ (4); $\varnothing 0.24$ (6)
- D. 4 mm probe: $\varnothing 0.86$ (22); 6 mm probe: $\varnothing 1.10$ (28)
- E. The PTFE covered probe is designed with a protective plate
- F. $\varnothing 0.28$ (7) for PTFE covered probe
- G. 17.1 (434) for PTFE covered probe
- H. $\varnothing 0.88$ (22.5) for PTFE covered probe
- I. Short weight (option W2)
- J. Heavy weight (option W3)
- K. Chuck

Dimensions are in inches (millimeters).

Figure 44: Flexible Single Lead with Threaded Connection

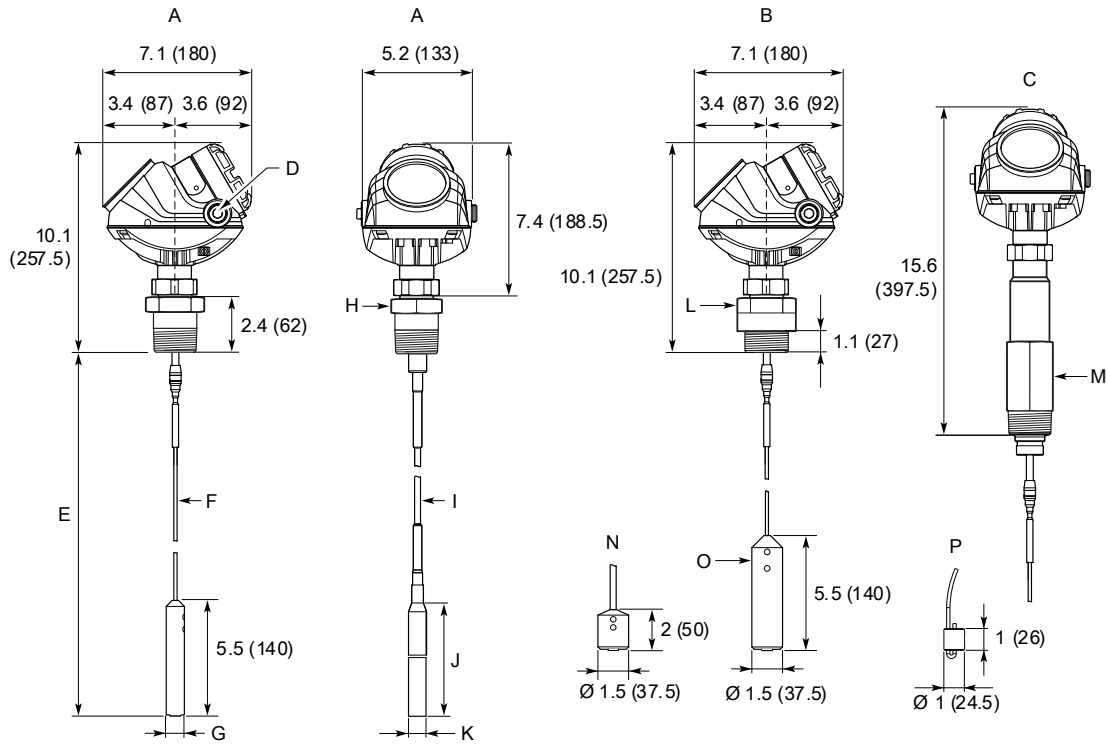

- A. NPT 1/1½/2 in.
- B. G 1/1½ in.
- C. NPT 1½, G 1½ in. (HTHP/HP/C version)
- D. ½ - 14 NPT; optional adapters: M20x1.5, eurofast and minifast
- E. L ≤ 164 ft. (50 m)
- F. Ø 0.16 (4); Ø 0.24 (6)
- G. 4 mm probe: Ø 0.86 (22); 6 mm probe: Ø 1.10 (28)
- H. 1 in. / 1½ in.: s52; 2 in.: s60
- I. Ø 0.28 (7) for PTFE covered probe
- J. 17.1 (434) for PTFE covered probe
- K. Ø 0.88 (22.5) for PTFE covered probe
- L. 1 in.: s52; 1½ in.: s60
- M. NPT: s50; G: s60
- N. Short weight (option W2)
- O. Heavy weight (option W3)
- P. Chuck

Dimensions are in inches (millimeters).

Figure 45: Coaxial probe with Flange Connection

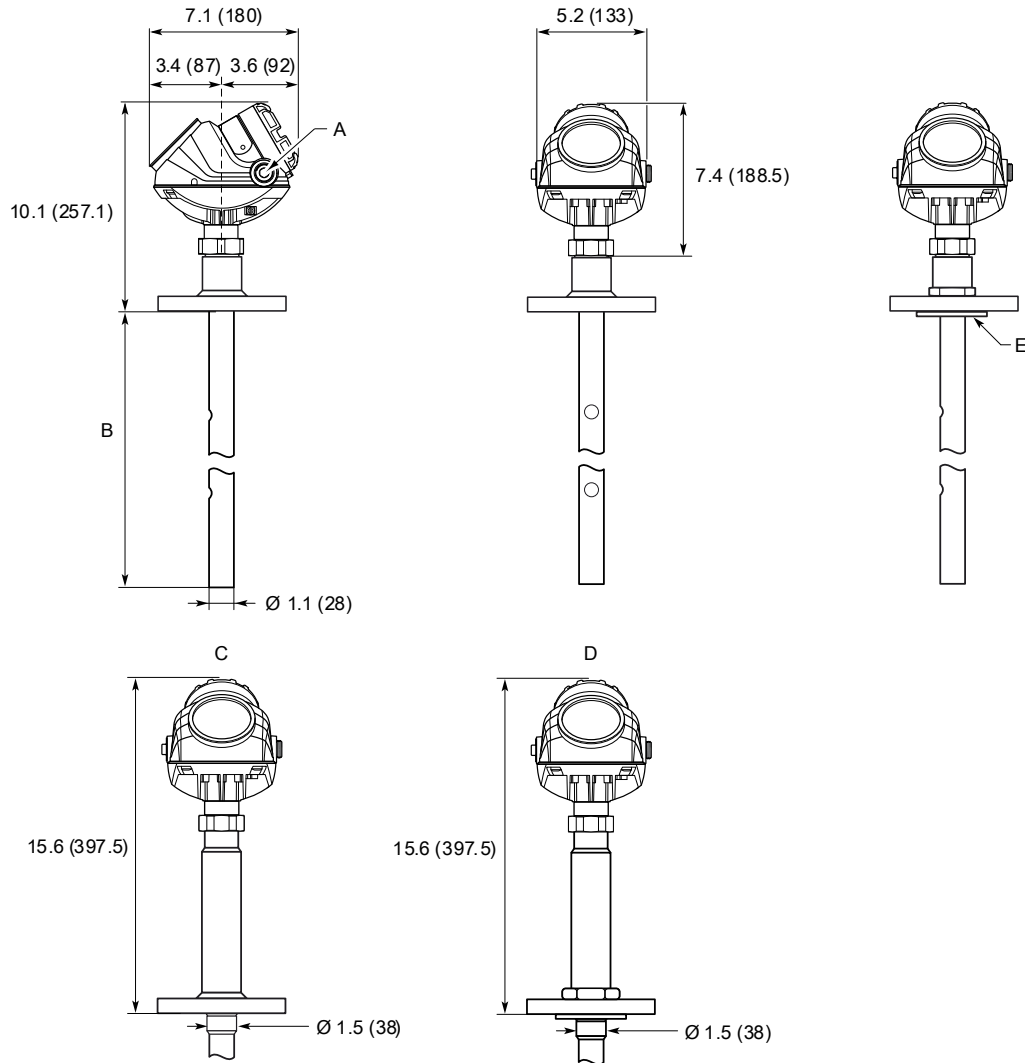

- A. 1/2 - 14 NPT; optional adapters: M20x1.5, eurofast and minifast
- B. L ≤ 20 ft. (6 m)
- C. HTHP/HP/C version
- D. HTHP/HP Plate Design (Option for Alloy versions)
- E. The Alloy probes are designed with a protective plate

Dimensions are in inches (millimeters).

Figure 46: Coaxial Probe with Threaded Connection

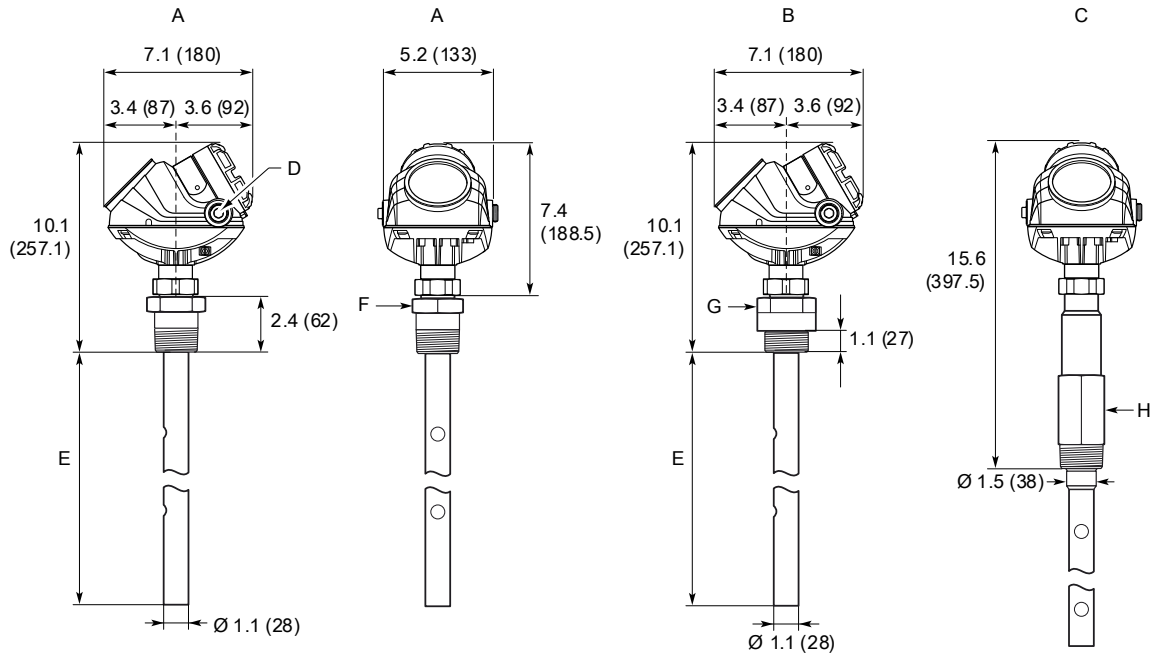

- A. NPT 1/1½/2 in.
- B. G 1/1½ in.
- C. NPT 1½, G 1½ inch (HTHP/HP/C version)
- D. ½ - 14 NPT; optional adapters: M20x1.5, eurofast and minifast
- E. L ≤ 20 ft (6 m)
- F. 1 in., 1½ in.: s52; 2 in.: s60
- G. 1 in.: s52; 1½ in.: s60
- H. NPT: s50; G: s60

Dimensions are in inches (millimeters).

Figure 47: Large Coaxial Probe with Flange Connection

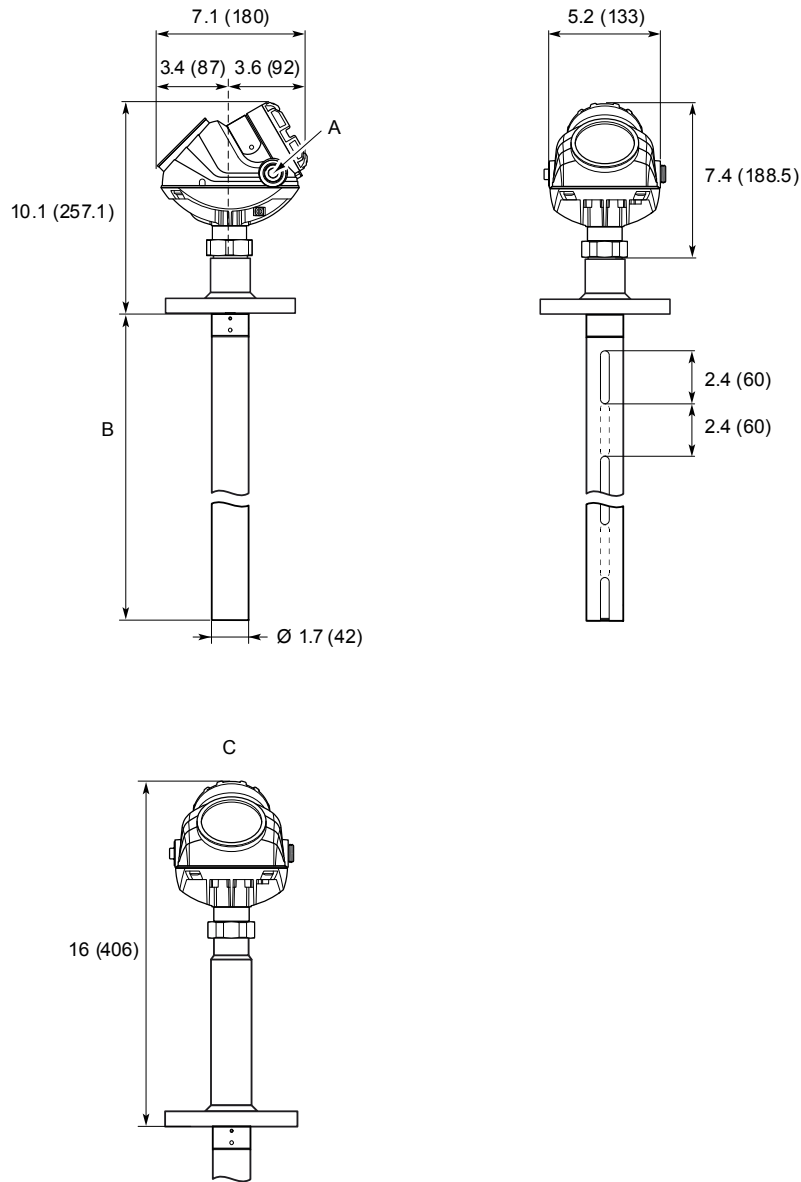

- A. $\frac{1}{2}$ - 14 NPT; optional adapters: M20x1.5, eurofast and minifast
- B. $L \leq 20$ ft. (6 m)
- C. HP/C version

Dimensions are in inches (millimeters).

Figure 48: Large Coaxial Probe with Threaded Connection

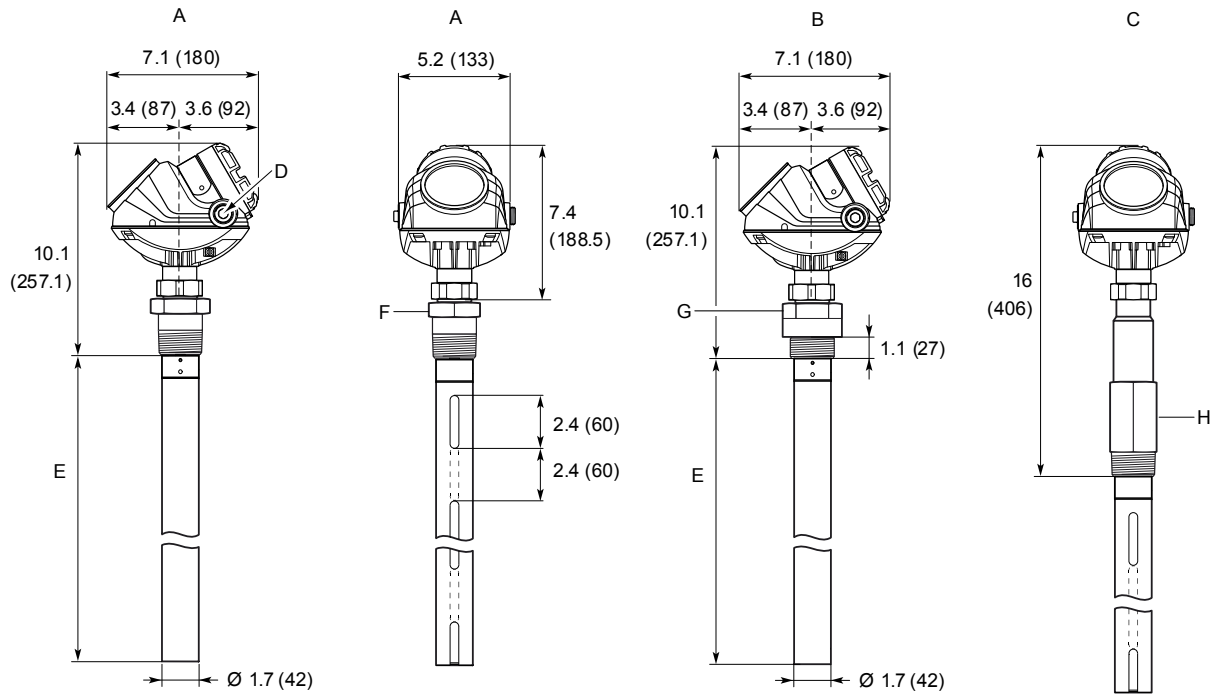

- A. NPT 1½ in.
- B. G 1½ in.
- C. NPT 1½, G 1½ in. (HP/C version)
- D. ½ - 14 NPT; optional adapters: M20x1.5, eurofast and minifast
- E. L ≤ 20 ft. (6 m)
- F. 1½ in.: s52; 2 in.: s60
- G. 1½ in.: s60
- H. NPT: s50; G: s60

Dimensions are in inches (millimeters).

Figure 49: Integrated Still Pipe Vapor Probe for 3-in. Chambers and above

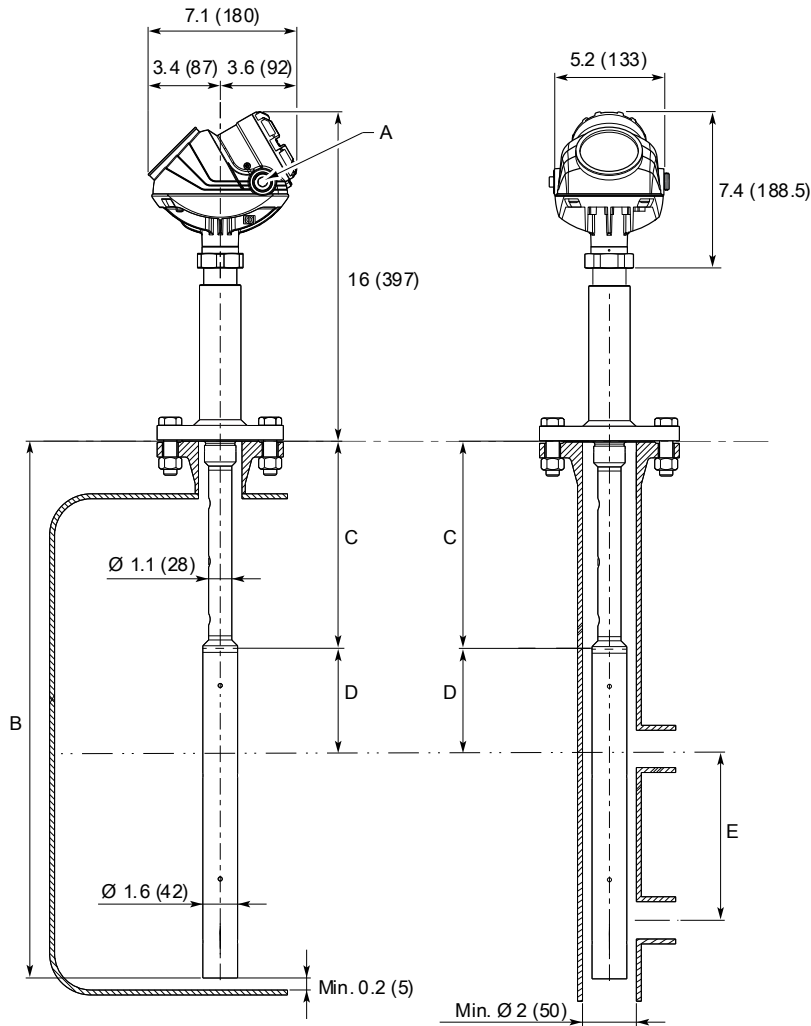

- A. 1/2 - 14 NPT; optional adapters: M20x1.5, eurofast and minifast
- B. L ≤ 13 ft. 1 in. (4 m)
- C. Short reflector: 13.8 (350); Long reflector: 19.7 (500)
- D. Minimum 8.3 in. (210 mm) distance between water surface and reflector end
- E. Minimum 12 in. (300 mm)

Dimensions are in inches (millimeters).

Figure 50: Rigid Twin Lead Probe

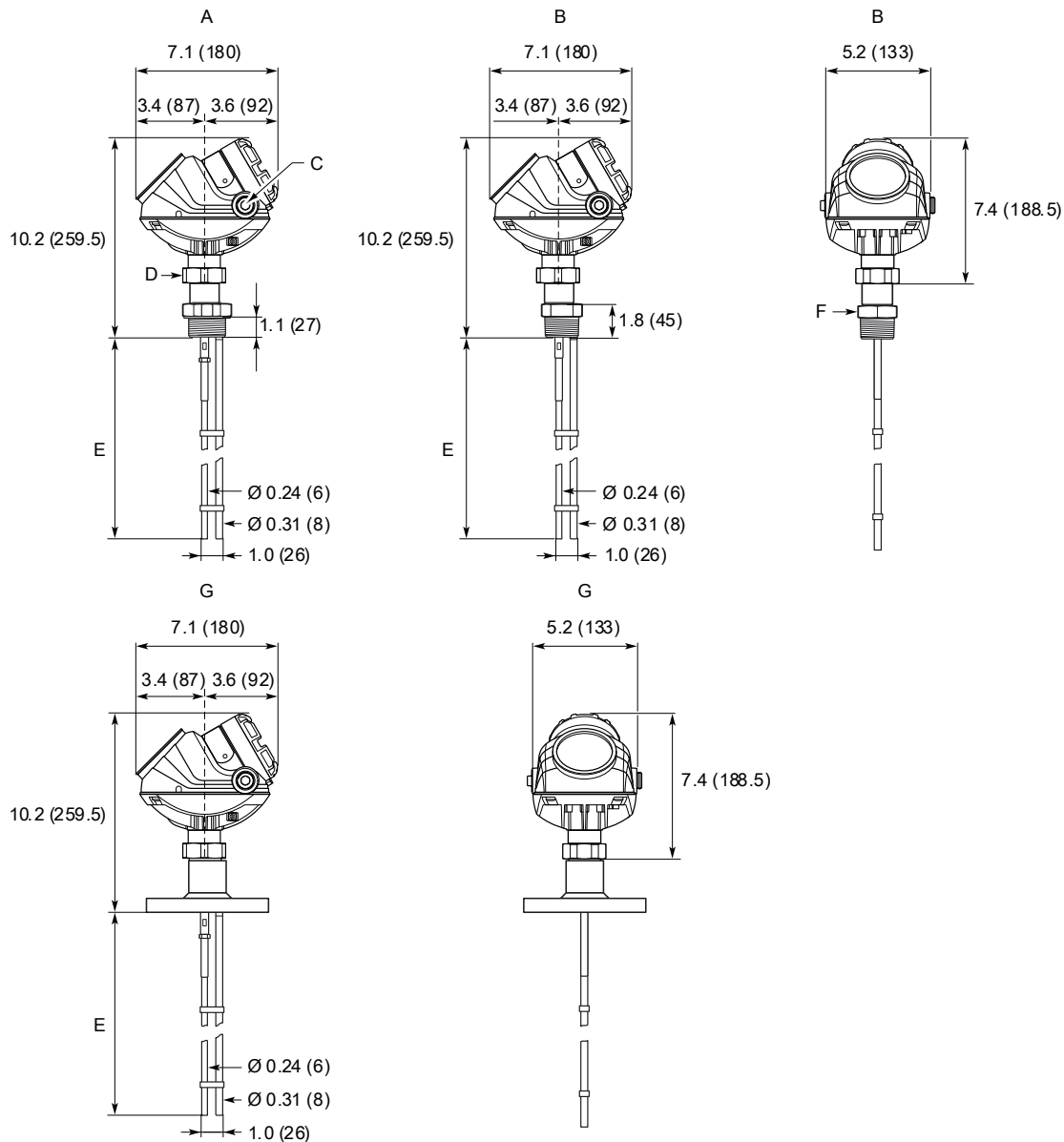

- A. G 1½ in.
- B. NPT 1½ / 2 in.
- C. ½ - 14 NPT; optional adapters: M20x1.5, eurofast and minifast
- D. s60
- E. L ≤ 10 ft. (3 m)
- F. 1½ in.: s52; 2 in.: s60
- G. Flange

Dimensions are in inches (millimeters).

Figure 51: Flexible Twin Lead Probe

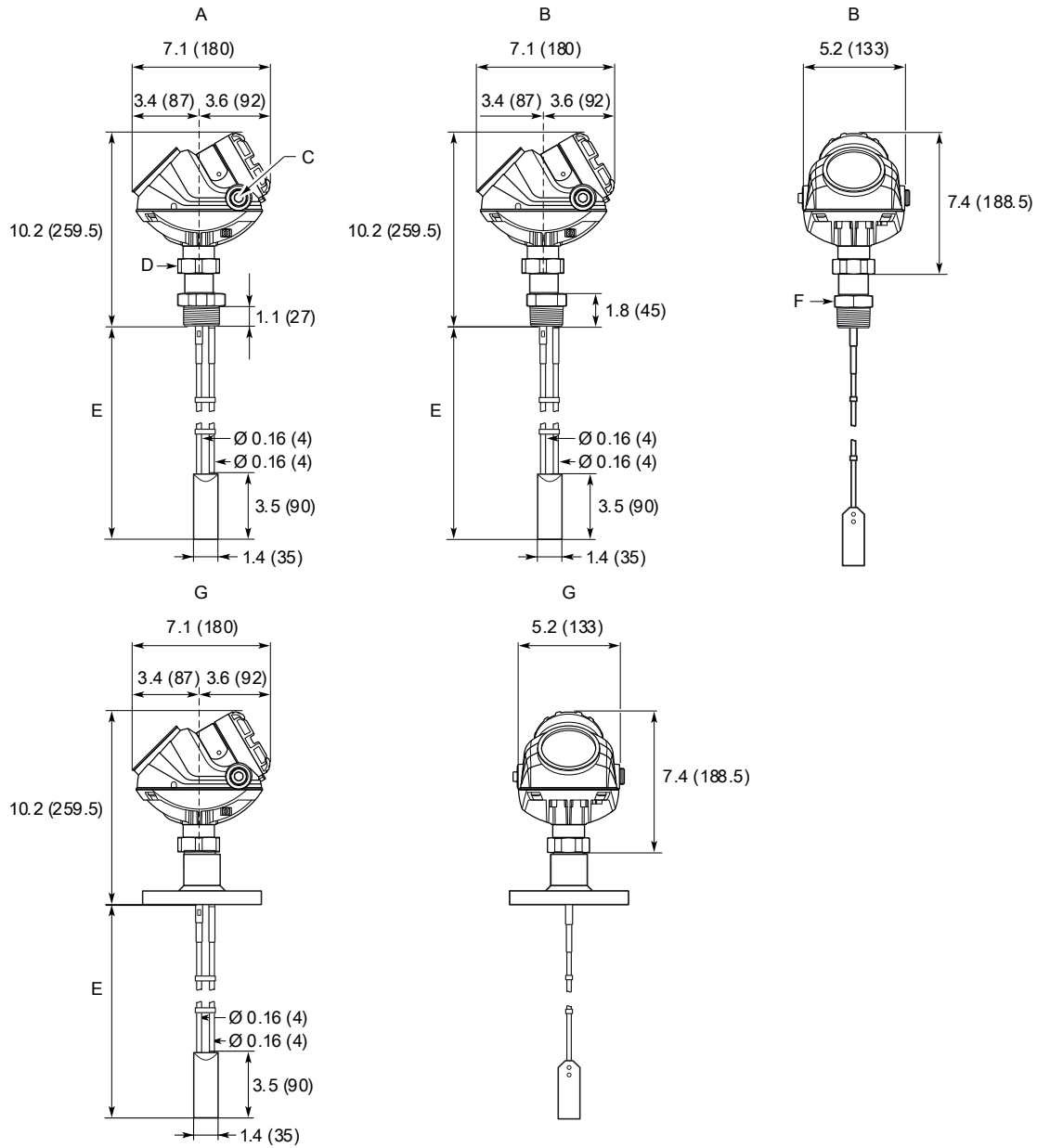

- A. G 1½ in.
- B. NPT 1½ / 2 in.
- C. ½ - 14 NPT; optional adapters: M20x1.5, eurofast and minifast
- D. s60
- E. L ≤ 164 ft. (50 m)
- F. 1½ in.: s52; 2 in.: s60
- G. Flange

Dimensions are in inches (millimeters).

Figure 52: Mounting Bracket (Option Code BR)

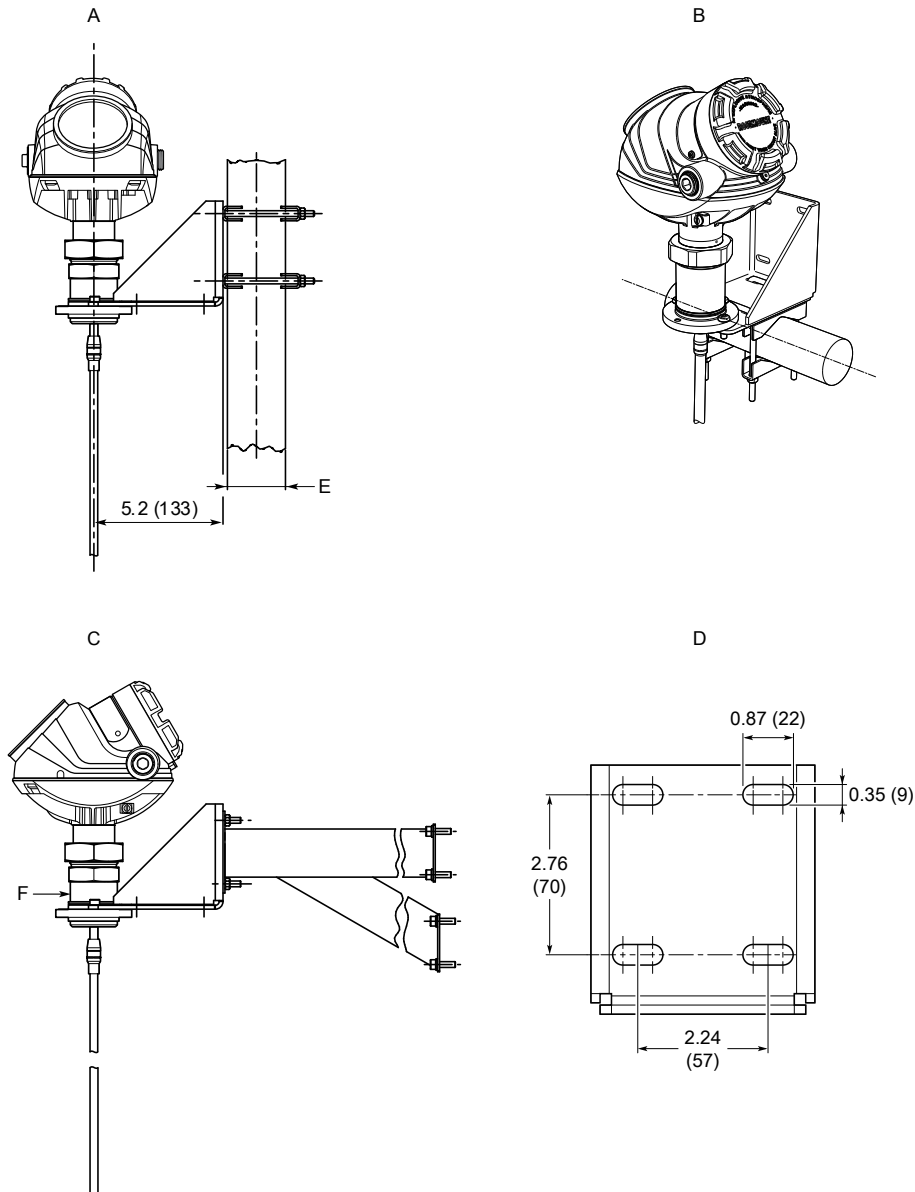

- A. Pipe mounting (vertical pipe)
- B. Pipe mounting (horizontal pipe)
- C. Wall mounting
- D. Hole pattern for wall mounting
- E. Pipe diameter: max 2.5 in. (64 mm)
- F. NPT 1½-in.

Dimensions are in inches (millimeters).

Figure 53: Remote Housing (Option Code B1, B2, B3)

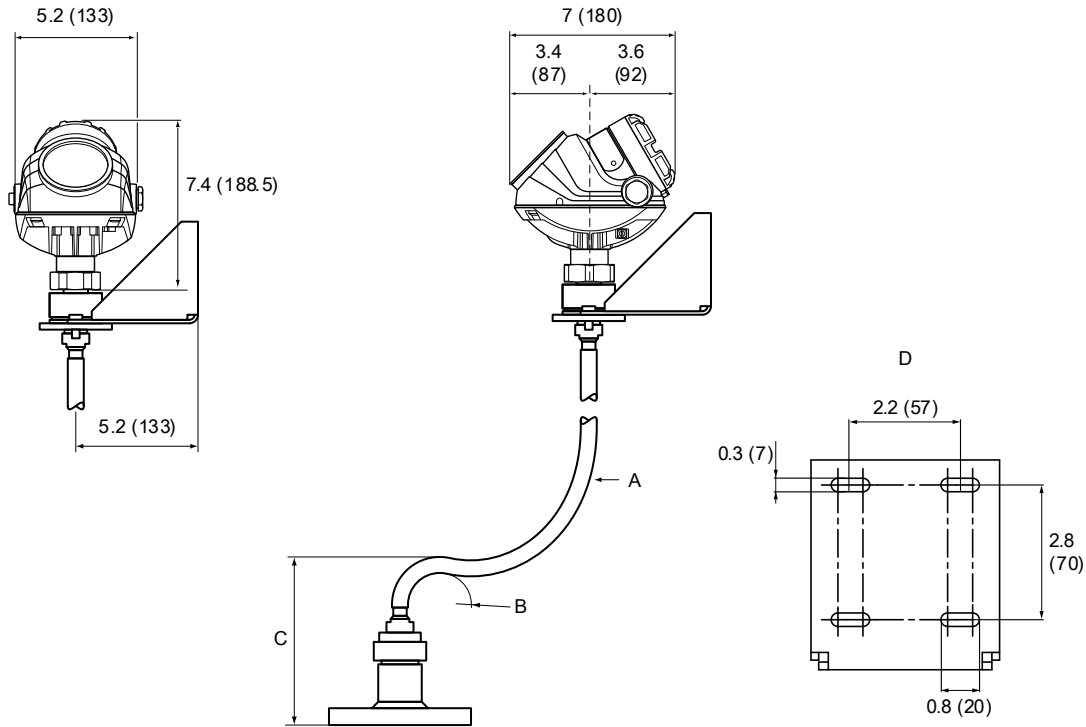

- A. 3, 6, 9 ft. (1, 2, or 3 m)
- B. R_{min} : 1.4 (35)
- C. H_{min} : 7.3 (185) for Standard variant; 12.8 (325) for HTHP/HP/C variant
- D. Hole pattern for remote housing wall mounting

Dimensions are in inches (millimeters).

Figure 54: Heat Sink (Option Code HS)

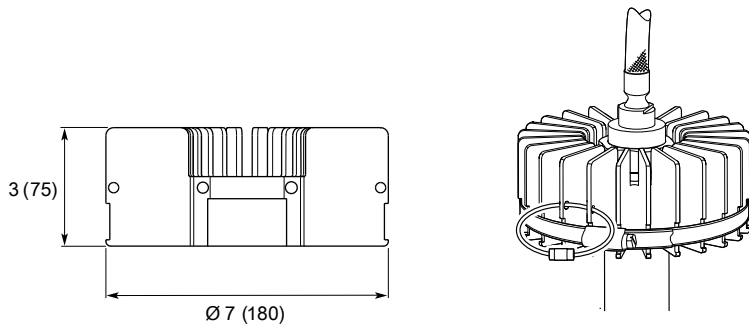

Dimensions are in inches (millimeters).

Proprietary flanges

Figure 55: Proprietary Flanges

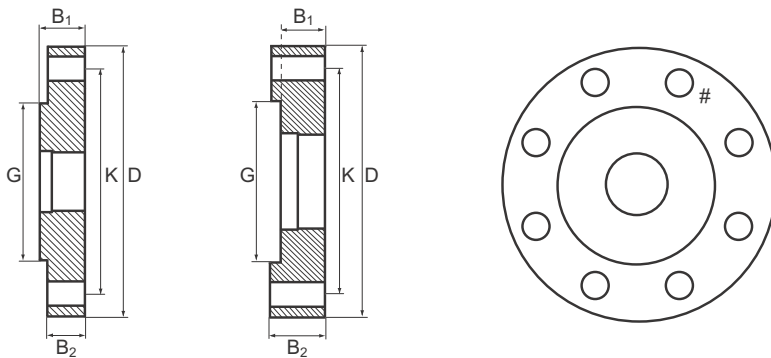

D: Outside diameter

B₁: Flange thickness with gasket surface

B₂: Flange thickness without gasket surface

F=B₁-B₂: Gasket surface thickness

G: Gasket surface diameter

Bolts: Number of bolts

K: Bolt hole circle diameter

Dimensions are in inches (millimeters).

Note

Dimensions may be used to aid in the identification of installed flanges. It is not intended for manufacturing use.

Table 34: Dimensions of Proprietary Flanges

Special flanges ⁽¹⁾	D	B ₁	B ₂	F	G	# Bolts	K
Fisher™ 249B/259B ⁽²⁾	9.00 (228.6)	1.50 (38.2)	1.25 (31.8)	0.25 (6.4)	5.23 (132.8)	8	7.25 (184.2)
Fisher 249C ⁽³⁾	5.69 (144.5)	0.94 (23.8)	1.13 (28.6)	-0.19 (-4.8)	3.37 (85.7)	8	4.75 (120.65)
Masoneilan™ ⁽²⁾	7.51(191.0)	1.54 (39.0)	1.30 (33.0)	0.24 (6.0)	4.02 (102.0)	8	5.87 (149.0)

(1) These flanges are also available in a vented version. Vented flanges must be ordered with a 1½-in. NPT threaded process connection (code RA).

(2) Flange with raised face.

(3) Flange with recessed face.

For information about flange temperature and pressure ratings, see [Fisher and Masoneilan flange rating](#).

Flushing connection rings

Figure 56: Flushing Connection Rings

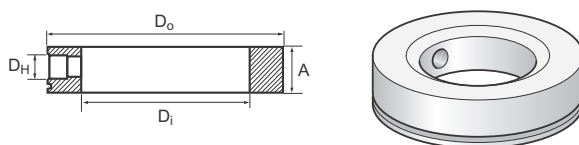

A. Height: 0.97 in. (24.6 mm)

Table 35: Dimensions of Flushing Connection Rings

Flushing connection rings	D _i	D _o	D _H
2-in. ANSI ⁽¹⁾	2.12 (53.8)	3.62 (91.9)	¼-in. NPT
3-in. ANSI ⁽¹⁾	3.60 (91.4)	5.00 (127.0)	¼-in. NPT
4-in. ANSI ⁽¹⁾ /DN100	3.60 (91.4)	6.20 (157.5)	¼-in. NPT
DN50	2.40 (61.0)	4.00 (102.0)	¼-in. NPT
DN80	3.60 (91.4)	5.43 (138.0)	¼-in. NPT

(1) Up to Class 2500.

For more information: [Emerson.com](https://www.emerson.com)

©2022 Emerson. All rights reserved.

Emerson Terms and Conditions of Sale are available upon request. The Emerson logo is a trademark and service mark of Emerson Electric Co. Rosemount is a mark of one of the Emerson family of companies. All other marks are the property of their respective owners.

ROSEMOUNT™

