

Rosemount™ 648 Wireless Temperature Transmitter

with Rosemount X-well™ Technology



- Rosemount X-well Technology provides accurate process temperature without the requirement of a thermowell or process penetration.
- Industry-leading temperature transmitter delivers field reliability as a wireless measurement solution.
- Achieve optimal efficiency with best-in-class product specifications and capabilities.
- Wireless delivers innovative wireless solutions for temperature measurement and overall transmitter performance.

Rosemount 648 Wireless Temperature Transmitter

Rosemount X-well Technology provides a Complete Point Solution™ for accurately measuring process temperature without the requirement of a thermowell or process penetration.



- Simplifies temperature measurement point specification, installation and maintenance, and eliminates possible leak points
- Calculates a repeatable and accurate process temperature measurement via an in-transmitter thermal conductivity algorithm
- Measures pipe surface and ambient temperature, and utilizes the thermal conductivity properties of the installation and process piping in order to provide an accurate process measurement

Industry-leading temperature transmitter delivers field reliability as a wireless measurement solution



- Superior accuracy and stability
- Single sensor capability with universal sensor inputs (RTD, T/C, mV, ohms)
- Transmitter-Sensor Matching with Callendar-Van Dusen
- IEC-approved *WirelessHART*® Protocol

Contents

Rosemount 648 Wireless Temperature Transmitter.....	2
Ordering information.....	6
How to order Rosemount X-well Technology.....	11
Specifications.....	12
Product certifications.....	19
Dimensional drawings.....	26

- Dual-compartment housing, available in aluminum or stainless steel
- Large LCD display
- Extended range antenna options available

Achieve optimal efficiency with best-in-class product specifications and capabilities

- Two-year stability rating reduces maintenance costs.
- Transmitter-sensor matching eliminates the interchangeability error of sensors, improving measurement point accuracy by 75 percent.
- User-centric Device Dashboards communicate important diagnostics and ensure process health.
- Compensation for ambient temperature enhances transmitter performance.
- Dual-compartment housing provides the highest reliability in harsh industrial environments.

A standard diagnostic offering increases measurement reliability and provides visibility into process conditions



- Four user-configurable alerts provide increased process information and measurement point insight.
- Open/short sensor diagnostics assist with detecting issues in sensor loops.
- Terminal temperature feature verifies installation location temperature conditions to ensure optimal transmitter operation.

Smart Wireless delivers innovative wireless solutions for temperature measurement and overall transmitter performance

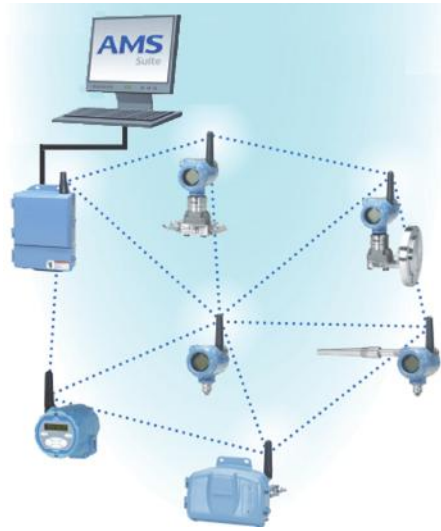

- Self-organizing network delivers information-rich data with 99-percent data reliability and establishes a highly stable network.
- Smart Wireless capabilities extend the full benefits of Plantweb™ to previously inaccessible temperature measurement locations.
- SmartPower™ Solutions provide an intrinsically safe power module, allowing field replacements without removing the transmitter from the process, keeping personnel safe, and reducing maintenance costs.
- Emerson Automation Solution’s layered approach to wireless network security ensures that data transmissions are secure.

Explore the benefits of a Complete Point Solution from Emerson



- An “Assemble To Sensor” option enables Emerson Automation Solutions to provide a complete point temperature solution, delivering an installation-ready transmitter and sensor assembly.
- Emerson offers a selection of RTDs, thermocouples, and thermowells that bring superior durability and Rosemount reliability to temperature sensing, complementing the Rosemount Transmitter portfolio.

Experience global consistency and local support from numerous worldwide Emerson manufacturing sites



- World-class manufacturing provides globally consistent product from every factory and the capacity to fulfill the needs of any project, large or small.
- Experienced instrumentation consultants help select the right product for any temperature application and advise on best installation practices.
- An extensive global network of Emerson service and support personnel can be on-site when and where they are needed.
- Make wireless installation and configuration easy with the Wireless Gateway.
- For installations that have a high number of temperature measurements in close proximity, consider the Rosemount 848T High Density Temperature Transmitter.
- Explore how Emerson's intrinsically safe SmartPower Solutions reduce maintenance costs.

Ordering information



The Rosemount 648 Wireless delivers industry-leading temperature field reliability as a wireless process measurement with best-in-class specifications and capabilities.

Transmitter features include:

- Temperature Measurement Assembly with Rosemount X-well Technology (option code PT)
- IEC-approved *WirelessHART* Protocol (option code WA3)
- External antenna (option code WK1)
- Extended range, external antenna (option code WM1)
- Large LCD display (option code M5)
- Transmitter-sensor matching (option code C2)
- 3-point calibration certificate (option code Q4)
- Assemble to sensor (option code XA)

[CONFIGURE >](#)

[VIEW PRODUCT >](#)

Online product configurator

Many products are configurable online using our Product Configurator. Select the **Configure** button or visit our [website](#) to start. With this tool's built-in logic and continuous validation, you can configure your products more quickly and accurately.

Model codes

Model codes contain the details related to each product. Exact model codes will vary; an example of a typical model code is shown in [Figure 1](#).

Figure 1: Model Code Example

3144P D1 A 1 NA M5 DA1 Q4

1

2

1. Required model components (choices available on most)
2. Additional options (variety of features and functions that may be added to products)

Specifications and options

See the Specifications and options section for more details on each configuration. Specification and selection of product materials, options, or components must be made by the purchaser of the equipment. See the Material selection section for more information on material selection.

When ordering Rosemount X-well Technology, specific option codes are required. See [How to order Rosemount X-well Technology](#) for more information.

Optimizing lead time

The starred offerings (★) represent the most common options and should be selected for best delivery. The non-starred offerings are subject to additional delivery lead time.

Required model components

Model

Code	Description	
648	Temperature transmitter	★

Transmitter type

Code	Description	
D	Wireless field mount	★

Transmitter output

Code	Description	
X	Wireless	★

Measurement configuration

Code	Description	
1	Single-sensor input	★

Housing style

Code	Description	Material	
D	Dual compartment housing	Aluminum	★
E	Dual compartment housing	SST	★

Conduit entry size

Code	Description	
1	½-4 NPT	★

Product certifications

Code	Description	
NA	No approval	★
I5	FM Intrinsically Safe, Non-Incendive, and Dust Ignition-proof	★

Code	Description	
N5	FM Non-Incendive and Dust Ignition-proof	★
I6	CSA Intrinsically Safe	★
I1	ATEX Intrinsic Safety	★
I7	ATEX Intrinsic Safety	★
I2	INMETRO Intrinsic Safety	★
I4	Japan Intrinsic Safety	★
I3	China Intrinsic Safety	★
IM	Technical Regulations Customs Union (EAC) Intrinsic Safety	★
KQ	USA, Canada, ATEX Intrinsic Safety Combination (combination of I1, I5, and I6)	★

Wireless options

Assemble to options

Code	Description	
XA ⁽¹⁾	Sensor specified separately and assembled to transmitter	★
XC	Hand tight assembly of a transmitter and sensor	★

(1) When ordering the XA option, a mounting bracket is not included. If a bracket is required, please order option code B5

Wireless update rate

Code	Description	
WA3	User configurable update rate, 2.4 GHz DSSS, IEC 62591 (<i>WirelessHART</i>)	★

Wireless antenna and SmartPower

Black power module must be shipped separately, order Model 701PBKKF or Part #00753-9220-0001.

Code	Description	
WK1	External antenna, adapter for Black Power Module (I.S. Power Module sold separately)	★
WM1	Extended range, external antenna, adapter for Black Power Module (I.S. Power Module sold separately)	

Mounting bracket

When ordering the XA option, a mounting bracket is not included. If a bracket is required, please order option code B5.

Code	Description	
B5	“L” mounting bracket for 2-in. pipe and panel mounting - All SST	★

Display

Code	Description	
M5	LCD display	★

Enhanced performance

When ordering the PT option code, the C1 and XA option codes are required. Rosemount X-well Technology is only available as a Rosemount 648 Wireless Temperature Transmitter and 0085 Pipe Clamp Sensor direct mount assembly.

Code	Description	
PT	Temperature measurement assembly with Rosemount X-well Technology	★

Software configuration

Custom configuration of date, descriptor, message, and wireless parameters (requires CDS with order)

Code	Description	
C1	Custom configuration of date, descriptor, message, and wireless parameters (requires CDS with order)	★

Line filter

Code	Description	
F5	50 Hz line voltage filter	★
F6	60 Hz line voltage filter	★

Sensorm trim

Code	Description	
C2	Transmitter-sensor matching - trim to specific Rosemount RTD calibration schedule (CVD Constants)	★

5-Point calibration

Code	Description	
C4	5-point calibration (requires Q4 option code to generate a Calibration Certificate)	★

Calibration certificate

Code	Description	
Q4	Calibration certificate (3-point calibration)	★

Cable Gland option

Code	Description	
G2	Cable gland (7.5–11.9 mm)	★
G4	Thin wire cable gland (3–8 mm)	★

Extended product warranty

Code	Description	
WR3	3-year limited warranty	★
WR5	5-year limited warranty	★

How to order Rosemount X-well Technology

Rosemount X-well Technology is only available as a Rosemount 648 Wireless and 0085 Pipe Clamp sensor direct mount assembly.

Table 1: Rosemount 648 Wireless Option Code Requirements

Code	Description
PT	Temperature measurement assembled with Rosemount X-well Technology
XA	Sensor specified separately and assembled to transmitter
C1	Custom configuration of date, descriptor, message, and wireless parameters (requires CDS with order)

Table 2: Rosemount 0085 Pipe Clamp Sensor Option Code Requirements

Code	Description
N	No connection head
3	Sensor connection
P1	Sensor type
J	Extension type
0080	Extension length
XA	Assemble sensor to specific temperature transmitter

Table 3: Pipe Schedules 40 and 80

Rosemount X-well assemblies are available in most Rosemount 0085 Pipe Clamp Sensor diameter sizes depending on the pipe schedule. The pipe diameters that correspond to the pipe schedules are shown in [Table 3](#).

Code	Suitable pipe size		Code	Suitable pipe size	
	Inch	DIN		Inch	DIN
0022	½	DN15	0324	12	DN 300
0027	¾	DN 20	0356	14	DN 350
0034	1	DN 25	0407	16	DN 400
0043	1¼	DN 32	0458	18	DN 450
0049	1½	DN 40	0508	20	DN 500
0061	2	DN 50	0610	24	DN 600
0077	2½	DN 65	0660	26	N/A
0089	3	DN 80	0762	30	DN 790
0115	4	DN 100	0813	32	DN 900
0140	5	DN 125	0915	36	DN 1000
0169	6	DN 150	1016	42	N/A
0220	8	DN 200	1070	42	N/A
0273	10	DN 250	1219	48	N/A

Table 4: Pipe Schedule 120

Code	Suitable pipe size	
	Inch	DIN
0115	4	DN 100
0140	5	DN 125
0169	6	DN 150
0220	8	DN 200
0273	10	DN 250
0324	12	DN 300
0356	14	DN 350
0407	16	DN 400
0458	18	DN 450
0508	20	DN 500
0610	24	DN 600

Note

For pipe schedules larger than 120, consult factory for more information.

Typical model number of the assembly: 648 D X 1 D 1 NA WA3 WK1 M5 PT C1 XA 0085 N 3 P1 J 0080 C 00169 N XA

Specifications

Physical specifications

Material selection

Emerson Automation Solutions provides a variety of Rosemount product with various product options and configurations including materials of construction that can be expected to perform well in a wide range of applications. The Rosemount product information presented is intended as a guide for the purchaser to make an appropriate selection for the application. It is the purchaser's sole responsibility to make a careful analysis of all process parameters (such as all chemical components, temperature, pressure, flow rate, abrasives, contaminants, etc.), when specifying product, materials, options, and components for the particular application. Emerson is not in a position to evaluate or guarantee the compatibility of the process fluid or other process parameters with the product, options, configuration, or materials of construction selected.

Conformance to specification ($\pm 3\sigma$ [Sigma])

Technology leadership, advanced manufacturing techniques, and statistical process control ensure measurement specification conformance to at least $\pm 3\sigma$.

Electrical connections

Power module

The Emerson SmartPower Power Module is field replaceable, featuring keyed connections that eliminate the risk of incorrect installation.

The power module is an Intrinsically Safe solution, containing Lithium-thionyl chloride with a polybutadine terephthalate (PBT) enclosure.

The Rosemount 648 Wireless has power module life time rating of 10 years with a one-minute update rate, at reference conditions.⁽¹⁾

Sensor terminals

Sensor terminals permanently fixed to terminal block.

Field Communicator connections

Communication terminals

Clips permanently fixed to terminal block, designated by the text “COMM.”

Materials of construction

Enclosure

Housing - low-copper aluminum or stainless steel

Paint - polyurethane

Cover O-ring - buna-N

Terminal block and power module

PBT

Antenna

PBT/Polycarbonate (PC) integrated omni-directional antenna

Mounting

Transmitters may be attached directly to the sensor. Mounting brackets also permit remote mounting. See [Dimensional drawings](#).

Weight

Low-copper aluminum

Rosemount 648 without LCD display - 4.1 lb (1.9 kg)

Rosemount 648 with M5 LCD display - 4.2 lb (2.0 kg)

Stainless steel

Rosemount 648 without LCD display - 8.0 lb (3.5 kg)

Rosemount 648 with M5 LCD display - 8.1 lb (3.6 kg)

Enclosure ratings (Rosemount 648)

Housing style option codes D and E are type 4X and IP66/67 rated dual-compartment housings.

Functional specifications

Input

Supports thermocouple, RTD, millivolt, and ohm input types. See [Table 6](#) for sensor options.

Output

IEC 62591 (*WirelessHART*), 2.4 GHz DSSS

Local display

The optional five-digit integral LCD display can display sensor temperature in engineering units (°F, °C, °R, K, Ω, and millivolts) and percent of range. The display updates based on the wireless update rate.

(1) Reference conditions are 70 °F (21 °C) and routing data for three additional network devices.

NOTE: Continuous exposure to ambient temperature limits (–40 or 185 °F; –40 or 85 °C) may reduce specified life by less than 20 percent.

Humidity limits

0–99% non-condensing relative humidity

Update rate

WirelessHART, user-selectable one second to 60 minutes

Accuracy

(Pt 100 at reference condition: 20 °C) ±0.225 °C (±0.405 °F)

Radio frequency power output from antenna

External antenna (WK1 option): Maximum of 10 mW (10 dBm) EIRP

Performance specifications

Electromagnetic compatibility (EMC)

All models:

Meets all relevant requirements of EN 61326-1; 2006; EN 61326-2-3; 2006

Transmitter stability

The Rosemount 648 has a stability of ±0.15% of output reading or 0.15 °C (whichever is greater) for 24 months.

Self calibration

The analog-to-digital measurement circuitry automatically self-calibrates for each temperature update by comparing the dynamic measurement to extremely stable and accurate internal reference elements.

Vibration effect

Tested to the following with no effect on performance per IEC 60770-1, 1999:

High vibration level - field or pipeline (10–60 Hz 0.21 mm displacement peak amplitude/60–2000 Hz 3 g).

Frequency	Acceleration
10-60 Hz	0.21 mm peak displacement
60-2000 Hz	3 g

Figure 2: Sensor Connections

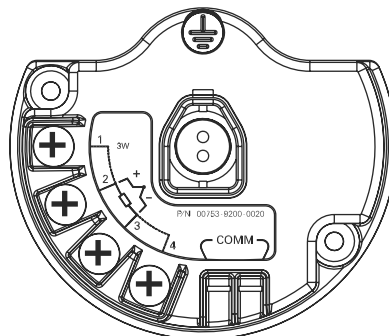
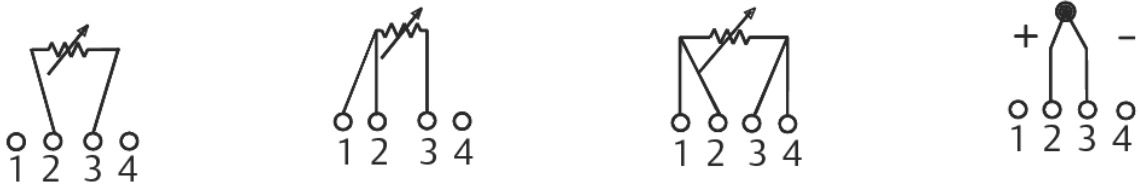

Figure 3: Rosemount 648 Wireless Sensor Connections



2-wire RTD and Ω ⁽¹⁾

3-wire RTD and Ω ⁽¹⁾

4-wire RTD and Ω

T/C and mV

(1) Emerson Automation Solutions provides 4-wire sensors for all single element RTDs. You can use these RTDs in 3- or 2-wire configurations by leaving the unneeded leads disconnected and insulated with electrical tape.

Table 5: Temperature Limits

Description	Operating limit	Storage limit
Without LCD display	-40 to 185 °F	-40 to 185 °F
	-40 to 85 °C	-40 to 85 °C
With LCD display	-4 to 175 °F	-40 to 185 °F
	-20 to 80 °C	-40 to 85 °C

Table 6: Rosemount 648 Wireless Input Options and Accuracy

Sensor options	Sensor reference	Input ranges		Digital accuracy ⁽¹⁾	
		°C	°F	°C	°F
2-, 3-, 4-wire RTDs					
Pt 100 ($\alpha = 0.00385$)	IEC 751	-200 to 850	-328 to 1562	± 0.225	± 0.405
Rosemount X-well Pt 100 ($\alpha = 0.00385$)	IEC 751	-50 to 300	-58 to 572	± 0.29	± 0.52
Pt 200 ($\alpha = 0.00385$)	IEC 751	-200 to 850	-328 to 1562	± 0.405	± 0.729
Pt 500 ($\alpha = 0.00385$)	IEC 751	-200 to 850	-328 to 1562	± 0.285	± 0.513
Pt 1000 ($\alpha = 0.00385$)	IEC 751	-200 to 300	-328 to 572	± 0.285	± 0.513
Pt 100 ($\alpha = 0.003916$)	JIS 1604	-200 to 645	-328 to 1193	± 0.225	± 0.405
Pt 200 ($\alpha = 0.003916$)	JIS 1604	-200 to 645	-328 to 1193	± 0.405	± 0.729
Ni 120	Edison Curve No. 7	-70 to 300	-94 to 572	± 0.225	± 0.405
Cu 10	Edison Copper Winding No. 15	-50 to 250	-58 to 482	± 2.1	± 3.78
Pt 50 ($\alpha = 0.00391$)	GOST 6651-94	-200 to 550	-328 to 990	± 0.45	± 0.81
Pt 100 ($\alpha = 0.00391$)	GOST 6651-94	-200 to 550	-328 to 990	± 0.225	± 0.405
Cu 50 ($\alpha = 0.00426$)	GOST 6651-94	-50 to 200	-58 to 392	± 0.72	± 1.296
Cu 50 ($\alpha = 0.00428$)	GOST 6651-94	-185 to 200	-301 to 392	± 0.72	± 1.296
Cu 100 ($\alpha = 0.00426$)	GOST 6651-94	-50 to 200	-58 to 392	± 0.36	± 0.648
Cu 100 ($\alpha = 0.00428$)	GOST 6651-94	-185 to 200	-301 to 392	± 0.36	± 0.648
Thermocouples⁽²⁾					
Type B ⁽³⁾	NIST Monograph 175, IEC 584	100 to 1820	212 to 3308	± 1.155	± 2.079
Type E	NIST Monograph 175, IEC 584	-200 to 1000	-328 to 1832	± 0.30	± 0.54

Table 6: Rosemount 648 Wireless Input Options and Accuracy (continued)

Sensor options	Sensor reference	Input ranges		Digital accuracy ⁽¹⁾	
Type J	NIST Monograph 175, IEC 584	-180 to 760	-292 to 1400	±0.525	±0.945
Type K ⁽⁴⁾	NIST Monograph 175, IEC 584	-180 to 1372	-292 to 2501	±0.75	±1.35
Type N	NIST Monograph 175, IEC 584	-200 to 1300	-328 to 2372	±0.75	±1.35
Type R	NIST Monograph 175, IEC 584	0 to 1768	32 to 3214	±1.125	±2.025
Type S	NIST Monograph 175, IEC 584	0 to 1768	32 to 3214	±1.05	±1.89
Type T	NIST Monograph 175, IEC 584	-200 to 400	-328 to 752	±0.525	±0.945
DIN type L	DIN 43710	-200 to 900	-328 to 1652	±0.525	±0.945
DIN type U	DIN 43710	-200 to 600	-328 to 1112	±0.525	±0.945
Type W5Re/W26Re	ASTM E 988-96	0 to 2000	32 to 3632	±1.05	±1.89
GOST L	GOST R 8.585-2001	-200 to 800	-328 to 1472	±0.525	±0.945
Other input types					
Millivolt input		-10 to 100 mV		±0.0225 mV	
2-, 3-, 4-wire Ohm input		0 to 2000 ohms		±0.675 ohm	

(1) The published digital accuracy applies over the entire sensor input range. Digital output can be accessed by HART® Communications or WirelessHART.

(2) Total digital accuracy for thermocouple measurement: sum of digital accuracy +0.8 °C. (cold junction accuracy).

(3) Digital accuracy for NIST Type B T/C is ±4.5 °C (±8.1 °F) from 100 to 300 °C (212 to 572 °F).

(4) Digital accuracy for NIST Type K T/C is ±1.05 °C (±1.895 °F) from -180 to -90 °C (-292 to -130 °F).

Table 7: Ambient Temperature Effect on Digital Accuracy

Sensor options	Sensor reference	Effects per 1.8 °F (1.0 °C) change in ambient temperature ⁽¹⁾⁽²⁾	Input temperature (T)
2-, 3-, 4-wire RTDs			
Pt 100 ($\alpha = 0.00385$)	IEC 751	0.0081 °F (0.0045 °C)	Entire sensor input range
Rosemount X-well Pt 100 ($\alpha = 0.00385$)	IEC 751	0.0104 °F (0.0058 °C)	Entire sensor input range
Pt 200 ($\alpha = 0.00385$)	IEC 751	0.0108 °F (0.006 °C)	Entire sensor input range
Pt 500 ($\alpha = 0.00385$)	IEC 751	0.0081 °F (0.0045 °C)	Entire sensor input range
Pt 1000 ($\alpha = 0.00385$)	IEC 751	0.0081 °F (0.0045 °C)	Entire sensor input range
Pt 100 ($\alpha = 0.003916$)	JIS 1604	0.0108 °F (0.0045 °C)	Entire sensor input range
Pt 200 ($\alpha = 0.003916$)	JIS 1604	0.0108 °F (0.006 °C)	Entire sensor input range
Ni 120	Edison Curve No. 7	0.0081 °F (0.0045 °C)	Entire sensor input range
Cu 10	Edison Copper Winding No. 15	0.081 °F (0.045 °C)	Entire sensor input range
Pt 50 ($\alpha = 0.003910$)	GOST 6651-94	0.0162 °F (0.009 °C)	Entire sensor input range
Pt 100 ($\alpha = 0.003910$)	GOST 6651-94	0.0081 °F (0.0045 °C)	Entire sensor input range
Cu 50 ($\alpha = 0.00426$)	GOST 6651-94	0.0162 °F (0.009 °C)	Entire sensor input range
Cu 50 ($\alpha = 0.00428$)	GOST 6651-94	0.0162 °F (0.009 °C)	Entire sensor input range
Cu 100 ($\alpha = 0.00426$)	GOST 6651-94	0.0081 °F (0.0045 °C)	Entire sensor input range

Table 7: Ambient Temperature Effect on Digital Accuracy (continued)

Sensor options	Sensor reference	Effects per 1.8 °F (1.0 °C) change in ambient temperature ⁽¹⁾⁽²⁾	Input temperature (T)
Cu 100 ($\alpha = 0.00428$)	GOST 6651-94	0.0081 °F (0.0045 °C)	Entire sensor input range
Thermocouples			
Type B	NIST Monograph 175, IEC 584	0.021 °C	$T \geq 1000$ °C
		0.048 °C – [0.00375% of (T – 300)]	300 °C $\leq T < 1000$ °C
		0.081 °C – [0.0165% of (T – 100)]	100 °C $\leq T < 300$ °C
Type E	NIST Monograph 175, IEC 584	0.0075 °C +(0.000645% of T)	All
Type J	NIST Monograph 175, IEC 584	0.0081 °C +(0.000435% of T)	$T \geq 0$ °C
		0.0081 °C + (0.00375% of absolute value T)	$T < 0$ °C
Type K	NIST Monograph 175, IEC 584	0.0092 °C +(0.00081% of T)	$T \geq 0$ °C
		0.0092 °C + (0.00375% of absolute value T)	$T < 0$ °C
Type N	NIST Monograph 175, IEC 584	0.0102 °C +(0.00054% of T)	All
Type R	NIST Monograph 175, IEC 584	0.024 °C	$T \geq 200$ °C
		0.0345 °C – (0.0108% of T)	$T < 200$ °C
Type S	NIST Monograph 175, IEC 584	0.024 °C	$T \geq 200$ °C
		0.0345 °C – (0.0108% of T)	$T < 200$ °C
Type T	NIST Monograph 175, IEC 584	0.0096 °C	$T \geq 0$ °C
		0.0096 °C +(0.00645% of absolute value T)	$T < 0$ °C
DIN type L	DIN 43710	0.0081 °C + (0.000435% of T)	$T \geq 0$ °C
		0.0081 °C +(0.00375% of absolute value T)	$T < 0$ °C
DIN type U	DIN 43710	0.0096 °C	$T \geq 0$ °C
		0.0096 °C +(0.00645% of absolute value T)	$T < 0$ °C
Type W5Re/W26Re	ASTM E 988-96	0.024 °C	$T \geq 200$ °C
		0.0345 °C – (0.0108% of T)	$T < 200$ °C
GOST L	GOST R. 8.585-2001	0.0105 °C	$T \geq 0$ °C
		0.0105 °C + (0.0045% of absolute value T)	$T < 0$ °C
Other input types			
Millivolt input		0.0008 mV	Entire sensor input range
2-, 3-, 4-wire Ohm input		0.0126 Ω	Entire sensor input range

(1) Ambient temperature effect specification valid over minimum temperature span of 50 °F (28 °C).

(2) Change in ambient is with reference to the calibration temperature of the transmitter 68 °F (20 °C) from factory.

Transmitters can be installed in locations where the ambient temperature is between –40 and 85 °C (–40 and 185 °F). In order to maintain excellent accuracy performance, each transmitter is individually characterized over this ambient temperature range at the factory.

Table 8: Ambient and Process Temperature Difference Effect on Digital Accuracy

Sensor option	Sensor reference	Effects per 1.0 °C (1.8 °F) difference in ambient and process temperature	Input temperature (T)
Rosemount X-well Pt 100 ($\alpha = 0.00385$)	IEC 751	± 0.01 °C (0.018 °F)	Entire sensor input range

Temperature effects example

When using a Pt 100 ($\alpha = 0.00385$) sensor input at 30 °C ambient temperature:

- Digital temperature effects: 0.0045 °C \times (30 - 20) = 0.045 °C
- Worst case error: Digital + Digital temperature effects = 0.225 °C + 0.045 °C = 0.27 °C
- Total probable error: $\sqrt{0.225^2 + 0.045^2} = 0.23$ °C

Rosemount X-well temperature effects example

When using Rosemount X-well Technology at 30 °C ambient temperature and 100 °C process temperature:

- Digital ambient temperature effects: 0.0058 °C \times (30 - 20) = .058 °C
- Process temperature effects: 0.01 °C \times (100 - 30) = .70 °C
- Worst case error: Digital Accuracy + Digital ambient temperature effects + Process temperature effects = 0.29 °C + 0.058 °C + 0.70 °C = 1.05 °C
- Total probable error: $\sqrt{0.29^2 + 0.058^2 + 0.70^2} = 0.76$ °C

Product certifications

Rev. 3.10

European Directive Information

A copy of the EU Declaration of Conformity can be found at the end of the Quick Start Guide. The most recent revision of the EU Declaration of Conformity can be found at [Emerson.com/Rosemount](https://www.emerson.com/Rosemount).

Telecommunication Compliance

All wireless devices require certification to ensure they adhere to regulations regarding the use of the RF spectrum. Nearly every country requires this type of product certification.

Emerson is working with governmental agencies around the world to supply fully compliant products and remove the risk of violating country directives or laws governing wireless device usage.

FCC and IC

This device complies with Part 15 of the FCC Rules. Operation is subject to the following conditions: This device may not cause harmful interference. This device must accept any interference received, including interference that may cause undesired operation. This device must be installed to ensure a minimum antenna separation distance of 20 cm from all persons.

Ordinary Location Certification

As standard, the transmitter has been examined and tested to determine that the design meets the basic electrical, mechanical, and fire protection requirements by a nationally recognized test laboratory (NRTL) as accredited by the Federal Occupational Safety and Health Administration (OSHA).

North America

The US National Electrical Code® (NEC) and the Canadian Electrical Code (CEC) permit the use of Division marked equipment in Zones and Zone marked equipment in Divisions. The markings must be suitable for the area classification, gas, and temperature class. This information is clearly defined in the respective codes.

USA

15 U.S. Intrinsic Safety (IS), Nonincendive (NI), and Dust Ignition-proof (DIP)

Certificate FM 18US0009X

Standards FM Class 3600 — 2011, FM Class 3610 — 2010, FM Class 3611 — 2004, FM Class 3810 — 2005, ANSI/NEMA® 250 — 2003, ANSI/ISA-60079-0 — 2009, ANSI/ISA-60079-11 — 2009

Markings IS CL I, DIV 1, GP A, B, C, D; CL II, DIV 1, GP E, F, G; Class III, T4/T5; Class 1, Zone 0 AEx ia IIC T4/T5; T4(-50 °C ≤ T_a ≤ +70 °C), T5(-50 °C ≤ T_a ≤ +40 °C) when installed per Rosemount drawing 00648-1000; NI CL I, DIV 2, GP A, B, C, D

T4/T5; T4(-50 °C ≤ T_a ≤ +70 °C), T5(-50 °C ≤ T_a ≤ +40 °C) when installed per Rosemount drawing 00648-1000; DIP CL II, DIV 1, GP E, F, G; CL III, T5; T5(-50 °C ≤ T_a ≤ +85 °C); Type 4X; IP66

Special Conditions for Safe Use (X):

1. The Rosemount 648 Transmitter housing contains aluminum and is considered a potential risk of ignition by impact or friction. Care must be taken into account during installation and use to prevent impact and friction.
2. The surface resistivity of the antenna is greater than 1 GΩ . To avoid electrostatic charge build-up, it must not be rubbed or cleaned with solvents or dry cloth.
3. The Rosemount 648 Wireless Transmitter shall only be used with the 701PBKKF Rosemount SmartPower™ Battery Pack (P/N 00753-9220-0001), Computational Systems Inc Battery Pack (P/N MHM-89004) or alternatively the Perpetuum Intelligent Power Module Vibration Harvester (P/N IPM71008).

Sensor terminal parameters
U _o = 6.6 V
I _o = 26.2 mA
P _o = 42.6 mW
C _o = 23.8 μF
L _o = 50 mH

N5 U.S. Nonincendive (NI) and Dust Ignition-proof (DIP)

Certificate FM 3027705

Standards FM Class 3600 — 2011, FM Class 3611 — 2004, FM Class 3810 — 2005, ANSI/NEMA 250 — 2003

Markings NI CL I, DIV 2, GPA, B, C, D T4/T5; T4(-50 °C ≤ T_a ≤ +70 °C), T5(-50 °C ≤ T_a ≤ +40 °C); DIP CL II, DIV 1, GP E, F, G; CL III, T5; T5(-50 °C ≤ T_a ≤ +85 °C); Type 4X; IP66/67

Special Condition for Safe Use (X):

For use only with the Model 701PBKKF (P/N 753-9220-0001) Smart Power Battery Module, Computational Systems Inc Battery Pack (P/N MHM-89004) or alternatively the Perpetuum Intelligent Power Module Vibration Harvester (P/N IPM71008).

Canada

I6 Canada Intrinsically Safe

Certificate CSA 1143113

Standards CAN/CSA C22.2 No. 0-10, CAN/CSA C22.2 No. 94-M91, CSA Std C22.2 No. 142-M1987, CSA Std C22.2 No. 157-92, CSA Std C22.2 No. 60529:05

Markings Intrinsically Safe Class I, Division 1, Groups A, B, C and D T3C; Class 1, Zone 0, IIC, T3C; when connected per Rosemount drawing 00648-1020; Type 4X

Sensor terminal parameters
U _o = 6.6 V
I _o = 26.2 mA

Sensor terminal parameters
$P_o = 42.6 \text{ mW}$
$C_o = 23.8 \text{ }\mu\text{F}$
$L_o = 50 \text{ mH}$

Europe

I1 ATEX Intrinsic Safety

Certificate:	Baseefa07ATEX0011X
Standards:	EN 60079-0: 2012 + A11:2013, EN 60079-11: 2012
Markings:	ⓈII 1 G Ex ia IIC T4 Ga, T4(-60 °C ≤ T _a ≤ +70 °C) ⓈII 1 G Ex ia IIC T5 Ga, T5(-60 °C ≤ T _a ≤ +40 °C)

For use with Rosemount SmartPower power module part number 753-9220-0001, or for use with Emerson SmartPower option 701PBKKF.

Sensor terminal parameters
$U_o = 6.6 \text{ V}$
$I_o = 26.2 \text{ mA}$
$P_o = 42.6 \text{ mW}$
$C_o = 11 \text{ }\mu\text{F}$
$L_o = 25 \text{ mH}$

Special Conditions for Safe Use (X):

1. The surface resistivity of the antenna is greater than 1 GΩ. To avoid electrostatic charge build-up, it must not be rubbed or cleaned with solvents or dry cloth.
2. The power module may be replaced in a hazardous area. The power module has a surface resistivity greater than 1 GΩ and must be properly installed in the wireless device enclosure. Care must be taken during transportation to and from the point of installation to prevent electrostatic charge build-up.

NM ATEX Intrinsic Safety for Mining

Certificate:	Baseefa07ATEX0011X
Standards:	EN 60079-0: 2012 + A11:2013, EN 60079-11: 2012
Markings:	ⓈI M 1 Ex ia I Ma(-60 °C ≤ T _a ≤ +70 °C)

Sensor terminal parameters
$U_o = 6.6 \text{ V}$
$I_o = 26.2 \text{ mA}$

Sensor terminal parameters
$P_o = 42.6 \text{ mW}$
$C_o = 11 \text{ }\mu\text{F}$
$L_o = 25 \text{ mH}$

Special Conditions for Safe Use (X):

1. The surface resistivity of the antenna is greater than 1 GΩ. To avoid electrostatic charge build-up, it must not be rubbed or cleaned with solvents or dry cloth.
2. The power module may be replaced in a hazardous area. The power module has a surface resistivity greater than 1 GΩ and must be properly installed in the wireless device enclosure. Care must be taken during transportation to and from the point of installation to prevent electrostatic charge build-up.

International

I7 IECEx Intrinsic Safety

Certificate	IECEx BAS 07.0007X
Standards	IEC 60079-0: 2011, IEC 60079-11: 2011
Markings	Ex ia IIC T4 Ga, T4 (-60 °C ≤ T _a ≤ +70 °C) Ex ia IIC T5 Ga, T5 (-60 °C ≤ T _a ≤ +40 °C)

Sensor terminal parameters
$U_o = 6.6 \text{ V}$
$I_o = 26.2 \text{ mA}$
$P_o = 42.6 \text{ mW}$
$C_o = 11 \text{ }\mu\text{F}$
$L_o = 25 \text{ mH}$

Special Conditions for Safe Use (X):

1. The surface resistivity of the antenna is greater than 1 GΩ . To avoid electrostatic charge build-up, it must not be rubbed or cleaned with solvents or dry cloth.
2. The Model 701PBKKF Power Module may be replaced in a hazardous area. The Power Modules have a surface resistivity greater than 1 GΩ and must be properly installed in the wireless device enclosure. Care must be taken during transportation to and from the point of installation to prevent electrostatic charge build-up.
3. The Rosemount 648 enclosure may be made of aluminum alloy and given a protective polyurethane paint finish; however, care should be taken to protect it from impact or abrasion if located in a Zone 0 area.

Brazil

I2 Brazil Intrinsic Safety

Certificate UL-BR 15.0140X
Standards ABNT NBR IEC 60079-0:2013, ABNT NBR IEC 60079-11:2013
Markings Ex ia IIC T4 ($-60\text{ °C} \leq T_a \leq +70\text{ °C}$), Ex ia IIC T5 ($-60\text{ °C} \leq T_a \leq +40\text{ °C}$); IP66

Sensor terminal parameters
$U_o = 6.6\text{ V}$
$I_o = 26.2\text{ mA}$
$P_o = 42.6\text{ mW}$
$C_o = 11\text{ }\mu\text{F}$
$L_o = 25\text{ mH}$

Special Condition for Safe Use (X):

See certificate for special conditions.

China

I3 China Intrinsic Safety

Certificate GYJ21.3298X
Standards GB3836.1-2010, GB3836.4-2010, GB3836.20-2010
Markings Ex ia IIC T4/T5 Ga

T code	Ambient temperature
T4	$-60\text{ °C} \leq T_a \leq +70\text{ °C}$
T5	$-60\text{ °C} \leq T_a \leq +40\text{ °C}$

Sensor terminal parameters
$U_o = 6.6\text{ V}$
$I_o = 26.2\text{ mA}$
$P_o = 42.6\text{ mW}$
$C_o = 11\text{ }\mu\text{F}$
$L_o = 25\text{ mH}$

Special Condition for Safe Use (X):

See certificate for special conditions.

Japan

I4 Japan Intrinsic Safety

Certificate CML 18JPN2105X

Markings Ex ia IIC T5/T4 Ga

See certificate for ambient temperature ranges.

Sensor terminal parameters
$U_o = 6.6 \text{ V}$
$I_o = 26.2 \text{ mA}$
$P_o = 42.6 \text{ mW}$
$C_o = 11 \text{ }\mu\text{F}$
$L_o = 25 \text{ mH}$

Special Condition for Safe Use (X):

See certificate for special conditions.

EAC - Belarus, Kazakhstan, Russia

IM Technical Regulation Customs Union Intrinsic Safety

Markings 0Ex ia IIC T4/T5 Ga X, T4 ($-60 \text{ }^\circ\text{C} \leq T_a \leq +70 \text{ }^\circ\text{C}$) T5 ($-60 \text{ }^\circ\text{C} \leq T_a \leq +40 \text{ }^\circ\text{C}$)

Sensor terminal parameters
$U_o = 6.6 \text{ V}$
$I_o = 26.2 \text{ mA}$
$P_o = 42.6 \text{ mW}$
$C_o = 11 \text{ }\mu\text{F}$
$L_o = 25 \text{ mH}$

Special Condition for Safe Use (X):

See certificate for special conditions.

Republic of Korea

IP Republic of Korea Intrinsic Safety

Certificate 11-KB4BO-0071

Markings

Ex ia IIC T4/T5 T4 (-60 °C ~ +70 °C) T5 (-60 °C ~ +40 °C)

Sensor terminal parameters
$U_o = 6.6 \text{ V}$
$I_o = 26.2 \text{ mA}$
$P_o = 42.6 \text{ mW}$
$C_o = 10.9 \mu\text{F}$
$L_o = 25 \text{ mH}$

Special Condition for Safe Use (X):

See certificate for special conditions.

Combination

KQ

Combination of I1, I5, and I6

Dimensional drawings

Figure 4: Rosemount 648 Wireless Remote Mount

Pipe mounting

Transmitter mounting

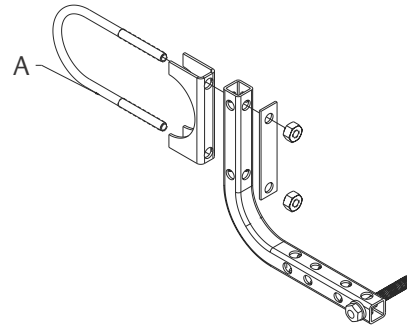
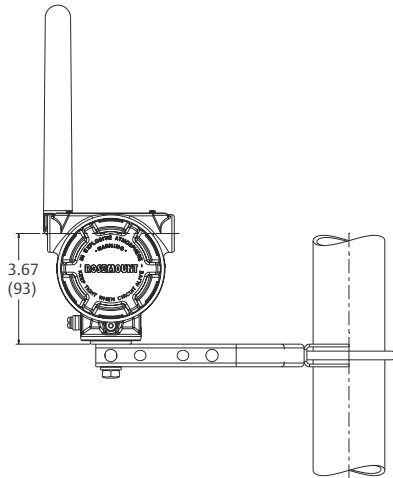

A. 2-in. U-bolt for pipe mounting

Dimensions are in inches (millimeters).

Figure 5: Rosemount 648 Wireless Direct Mount

Shown with 2.4 GHz extended range antenna

Shown with optional digital display and 2.4 GHz antenna

Shown without optional digital display

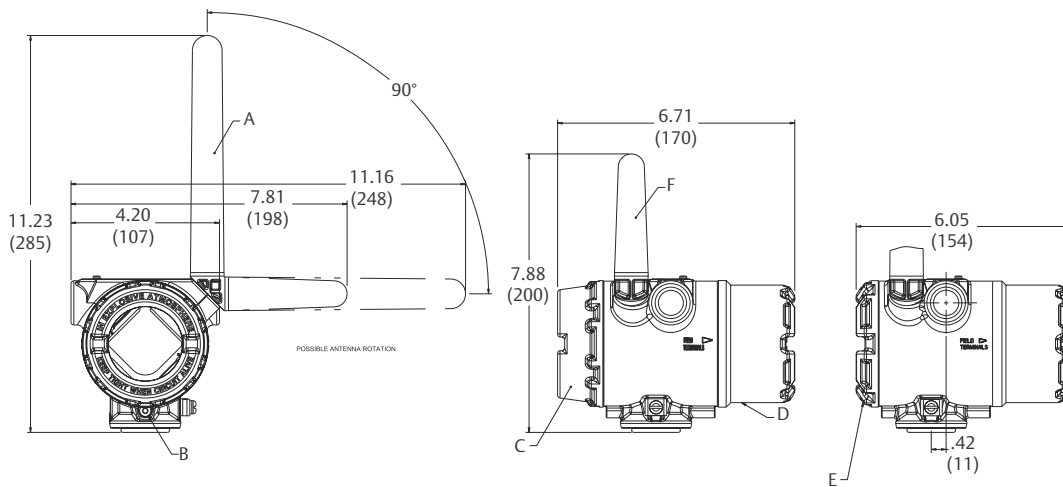

A. 2.4 GHz extended range antenna

B. Ground screw assembly

C. Digital display cover

Dimensions are in inches (millimeters).

D. Field terminal (this side)

E. Transmitter electronics (this side)

F. 2.4 GHz antenna

Figure 6: Rosemount 648 with Option Code PT

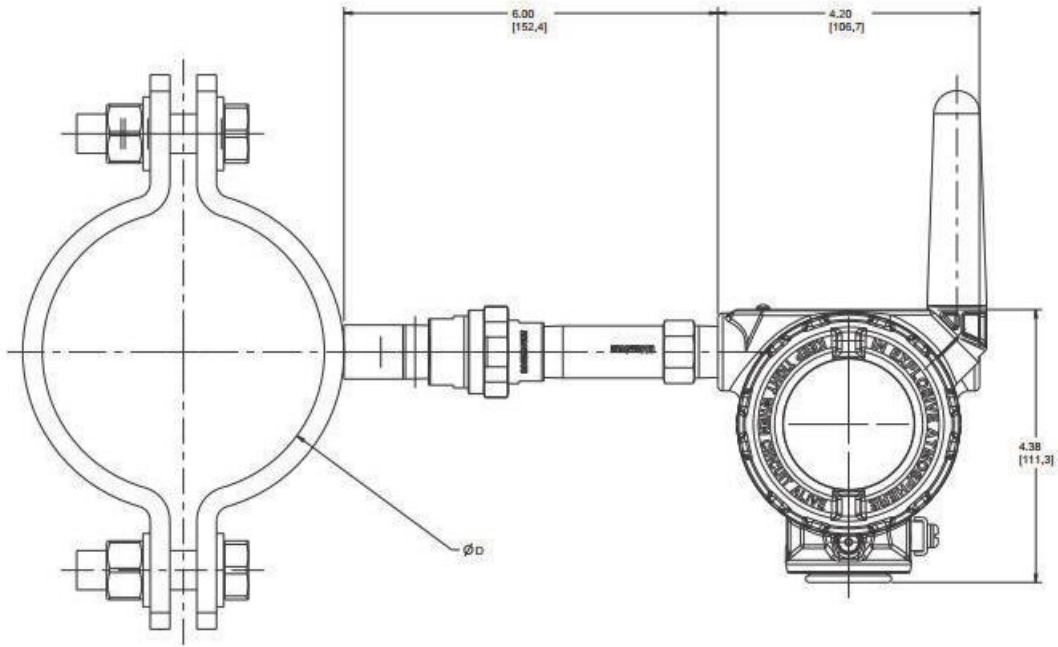

For more information: [Emerson.com](https://www.emerson.com)

©2022 Emerson. All rights reserved.

Emerson Terms and Conditions of Sale are available upon request. The Emerson logo is a trademark and service mark of Emerson Electric Co. Rosemount is a mark of one of the Emerson family of companies. All other marks are the property of their respective owners.

ROSEMOUNT™

