

General Specifications

GS 01C31Y01-01EN

EJAC60E
Hygienic Adapter System (Fluidless Type)
EJA560E
Hygienic Gauge Pressure Transmitter (Fluidless Type)



[Style: S2]

EJAC60E Hygienic Adapter System (Fluidless Type) consists of EJA560E Hygienic gauge pressure transmitter (Fluidless Type) and C10SA Hygienic adapter with various kind of process connections, and outputs a 4 to 20 mA DC signal corresponding to the measured pressure.

It also features quick response, remote setup and monitoring via HART communications and self-diagnostics.

Process connection style

- ISO 2852 Clamp
- ISO 2853 Union
- DIN 11851 Union
- GV In-line Clamp
- GV Clamp

Features

- Strain resistor type, no silicon resonator.
- High temperature: 150°C continuously
- Quick response: 120 ms
- High performance: Remote setup and monitoring via HART and self diagnostics
- Burst Pressure: 25 MPa (3600 psi)

EJAC60E represents a Hygienic Adapter System type. CE marking and other certification are acquired for model code of EJA560E transmitter. See section "MODEL AND SUFFIX CODES" of this document.

Hygienic Adapter System (Fluidless Type)	Applicable Transmitter
EJAC60E	EJA560E



PERFORMANCE SPECIFICATIONS

Zero-based calibrated span and linear output, unless otherwise mentioned.

Specification Conformance

EJA-E series ensures specification conformance to at least $\pm 3\sigma$.

Reference Accuracy of Calibrated Span

(includes the effects of terminal-based linearity, hysteresis, and repeatability)

Measurement span	Reference Accuracy	
	Span $\geq X$	Span $< X$
A	$\pm 0.15\%$ of Span	$\pm(0.0375 \text{ URL}/\text{span})\%$ of Span
B		$\pm(0.045 \text{ URL}/\text{span})\%$ of Span
C		$\pm(0.025 \text{ URL}/\text{span})\%$ of Span

Measurement span	A	B	C
X	100 kPa (14.5 psi)	0.3 MPa (43.5 psi)	0.5 MPa (72.5 psi)
URL (Upper range limit)	400 kPa (58 psi)	1 MPa (145 psi)	3 MPa (435 psi)

STANDARD SPECIFICATIONS

SPAN AND RANGE LIMITS

Measurement Span/Range	MPa	psi (/D1)	bar (/D3)	kgf/cm ² (/D4)
A	Span 20 to 400 kPa	2.9 to 58	0.2 to 4	0.2 to 4
	Range -100 to 400 kPa	-14.5 to 58	-1 to 4	-1 to 4
B	Span 0.1 to 1	14.5 to 145	1 to 10	1 to 10
	Range -0.1 to 1	-14.5 to 145	-1 to 10	-1 to 10
C	Span 0.3 to 3	43.5 to 435	3 to 30	3 to 30
	Range -0.1 to 3	-14.5 to 435	-1 to 30	-1 to 30

*: Hygienic clamps usually have a withstand pressure of 1 MPa (145 psi). If applied pressure exceed 1 MPa (145 psi), clamps with pressure resistance over 1 MPa (145 psi) is necessary.

Ambient Temperature Effects per 28°C (50°F)

Change (All capsules)
 $\pm(0.28\%$ of Span + 0.28% of URL)

Process Temperature Effects Steady State (All capsules)

$\pm(0.1\%$ of URL) per 10°C (18°F) Change

Transient State *

$\pm(8\%$ of URL) for A capsule.
 $\pm(4\%$ of URL) for B and C capsule.

- *: Reference value (this is not a guaranteed value). According to the results of the cold and hot water (temperature difference 90 \pm 5°C) evaluation test.
- *: If the measurement span is small, a setting of 10 or more seconds for the damping time constant is recommended. The output may temporarily exceed the setting range when the temperature of the measured rises rapidly. (Damping time constant can be specified by option code CA.)

Stability (All normal operating condition)

±0.2% of URL for 1 year

Power Supply Effects

±0.005% per Volt (from 21.6 to 32 V DC, 350Ω)

Vibration Effects

Less than 0.1% of URL when tested per the requirements of IEC60770-1 field with general application or pipeline with low vibration level (10-60 Hz, 0.15 mm displacement/60-2000 Hz 2g)

Mounting Position Effects

Rotation in diaphragm plane has no effect. Tilting up to 180 degree will cause zero shift up to ±0.1 kPa (0.4 in H₂O) which can be corrected by the zero adjustment.

Response Time (All capsules)

120 ms

When software damping is set to zero and including dead time of 60 ms (nominal)

□ **FUNCTIONAL SPECIFICATIONS**

Output

Two wire 4 to 20 mA DC output with digital communications, linear or square root programmable. HART FSK protocol is superimposed on the 4 to 20 mA signal.

Output range 3.6 mA to 21.6 mA

Output limits conforming to NAMUR NE43 can be pre-set by option code C2 or C3.

Failure Alarm

Output status at CPU failure and hardware error;
Up-scale: 110%, 21.6 mA DC or more (standard)
Down-scale: -5%, 3.2 mA DC or less

Damping Time Constant (1st order)

Amplifier's damping time constant is adjustable from 0.00 to 100.00 s by software and added to response time.

Update Period

Pressure: 60 ms

Zero Adjustment Limits

Zero can be fully elevated or suppressed, within the lower and upper range limits of the capsule.

External Zero Adjustment

External zero is continuously adjustable with 0.01% incremental resolution of span. Re-range can be done locally using the digital indicator with range setting switch.

Integral Indicator (LCD display, optional)

5-digit numerical display, 6-digit unit display and bar graph.

The indicator is configurable to display one or up to three of the following variables periodically; pressure in %, scaled pressure, measured pressure. See also "Factory Settings."

Local Parameter Setting

Parameter configuration by the external zero adjustment screw and push button (Integral indicator code E) offers easy and quick setup for parameters of Tag number, Unit, LRV, URV, Damping, Output mode (linear/square root), Display out 1, and Re-range by applying actual pressure (LRV/URV).

Burst Pressure Limits

25 MPa (3600 psi)

* : Wetted parts may be destroyed and process fluid is leaks out when exceeding burst pressure.

* : Required to confirm whether pressure exceed 1 MPa (145 psi) or not. (Normal sanitary clamp has a withstand 1 MPa (145 psi).)

Self Diagnostics

CPU failure, hardware failure, configuration error, process alarm for pressure or capsule temperature. User-configurable process high/low alarm for pressure is available.

Signal Characterizer

User-configurable 10-segment signal characterizer for 4 to 20 mA output.

Lightning protector

EJA560E adopts a lightning protector as standard. Allowable current: Max. 6000 A (1×40 μs), Repeating 1000 A (1×40 μs) 100 times
Applicable Standards: IEC 61000-4-4, IEC 61000-4-5

□ **NORMAL OPERATING CONDITION (Optional features or approval codes may affect limits.)**

Ambient Temperature Limits

-40 to 85°C (-40 to 185°F) (General)

-30 to 80°C (-22 to 176°F) (With LCD display)

For relationship between process temperature, see Figure 1

Process Temperature Limits

-20 to 150°C (-4 to 302°F)

For relationship between ambient temperature, see Figure 1

The ambient temperature below 33°C (91.4°F) is become unlimited at 150°C (302°F).

The ambient temperature between 33°C (91.4°F) and 70°C (158°F) are become limited at 150°C (302°F) per 60 minute.

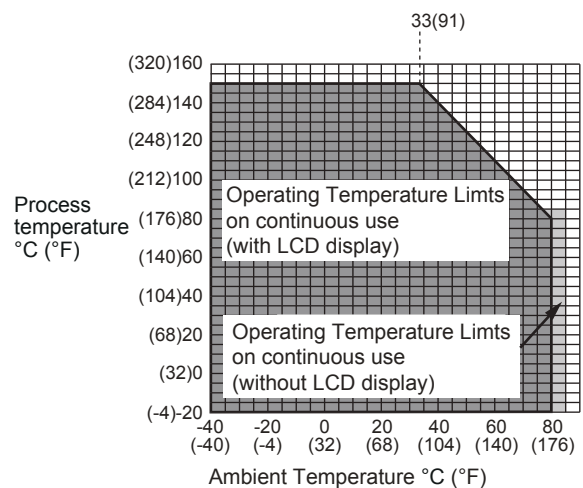

* Available for 1 hour continuously at process temperature 150°C (302°F) and ambient temperature 45°C (113°F)

Figure 1. Relationship Between Ambient Temperature and Process Temperature

Ambient Humidity Limits

0 to 100% RH

Maximum Over Pressure

Capsule	Pressure
A	2 MPa (290 psi)
B	5 MPa (720 psi)
C	7.5 MPa (1080 psi)

*: Calibration is needed once pressure exceed maximum over pressure.

Working Pressure Limits

0.00 kPa abs (Without Degree of Vacuum Limit) to URL (Upper Range Limit)

Behavior with regards to Over Pressure

Applied pressure also include maximum momentary pressure (surge pressure). The measurement method of this sensor is pressure detection using strain of metal diaphragm. The maximum momentary pressure exceeding the above pressure affects the characteristics of the sensor. The causes of the momentary pressure (surge pressure) are considered as follows:

- Surge pressure of bubbly mixed fluid when installed to the upper end of the pipe (Figure 2)
- Inrush pressure when installed to the bending pipe (Figure 3)
- Water hammer
- Steam explosion by steam and water contact (Figure 4)
- Direct washing of sensor with washing nozzle (Figure 5)

Concerning installation, please take the above contents into consideration while installing.

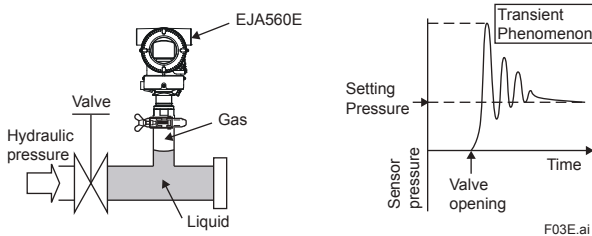

Figure 2. Surge Pressure of Bubbly Mixed Fluid When Installed to the Upper End of the Pipe

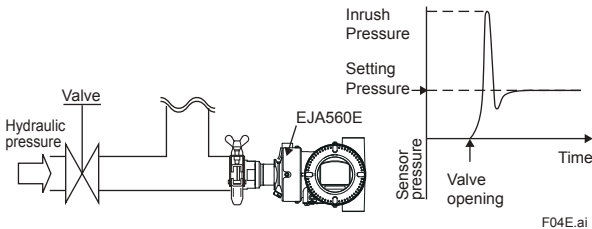

Figure 3. Inrush Pressure When Installed to the Bending Pipe

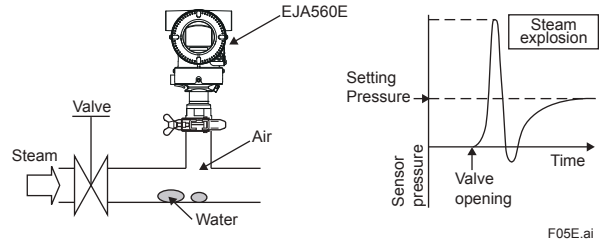

Figure 4. Steam Explosion by Steam and Water Contact

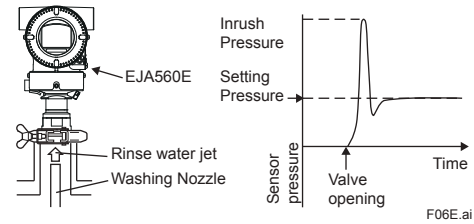

Figure 5. Direct washing of Sensor with Washing Nozzle

Supply & Load Requirements

With 24 V DC supply, up to 550Ω load can be used. See graph below.

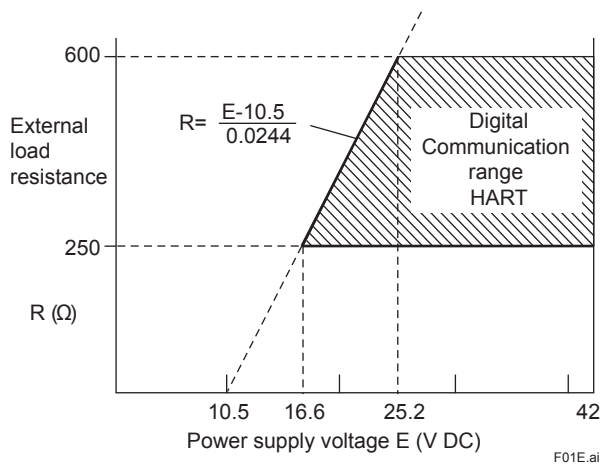

Figure 6. Relationship Between Power Supply Voltage and External Load Resistance

Supply Voltage

10.5 to 42 V DC

Minimum voltage limited at 16.6 V DC for digital communication, HART

Load

0 to 1290 Ω for operation

250 to 600 Ω for digital communication

Hygienic Standards

3-A Sanitary Certification *

*: Not applicable with GV Clamp DN40.

EMC Conformity Standards

EN 61326-1 Class A, Table2
EN 61326-2-3

EU RoHS Directive

EN IEC 63000

Safety Requirements Standards

EN 61010-1
• Installation category: I
(Anticipated transient overvoltage 330 V)
• Pollution degree: 2
• Indoor/Outdoor use

SIL Certification

None

□ **PHYSICAL SPECIFICATIONS**

Wetted Parts Materials

Diaphragm
Duplex stainless steel

The others
316L SST

O-ring
EPDM (Ethylene-propylene rubber) or
FKM (Fluoro-rubber)

Gasket
EPDM (Ethylene-propylene rubber) or
FKM (Fluoro-rubber)

Non-wetted Parts Materials

Housing
• Low copper cast aluminum alloy
• Stainless steel

Coating of Housing
[for aluminum housing]
Polyester resin powder coating Mint-green paint
(Munsell 5.6BG 3.3/2.9 or its equivalent)
[for option code /P□ or /X2]
Epoxy and polyurethane resin solvent coating

Degrees of Protection
IP66/IP67, Type 4X

Pipe
Polyamide

Cover O-rings
[for aluminum housing]
Buna-N, fluoro-rubber (optional)
[for stainless housing]
Silicon

Name Plate and Tag
316 SST or Polyester Label *
*: for amplifier housing code 5 or option code /3A

Clamp
304 SST or SCS 13

Coupling Nut
304 SST

Weight *
[for aluminum housing]
1.3 kg (2.9 lb)
[for stainless housing]
1.4 kg (3.0 lb)
*: Without integral indicator, with ISO 25/38 clamp

Connections
Refer to "MODEL AND SUFFIX CODES."

< Related Instruments >

FieldMate Versatile Device Management Wizard:
Refer to GS 01R01A01-01E.
Power Distributor: Refer to GS 01B04T01-02E or
GS 01B04T02-02E

< Reference >

- *DPHarp EIA*; Registered trademark or trademark of Yokogawa Electric Corporation.
- FieldMate; Registered trademark or trademark of Yokogawa Electric Corporation.
- HART®; Registered trademark of FieldComm Group.

Other company names and product names used in this material are registered trademarks or trademarks of their respective owners.

■ MODEL AND SUFFIX CODES

The model codes of Hygienic Adapter System (Fluidless Type) consist of a transmitter part and an adapter part. Various kinds of products can be realized by combining a transmitter with an adapter. This sheet describes the codes of the hygienic adapter system, a transmitter part and an adapter part.

EJAC60E Hygienic Adapter System (Fluidless Type)

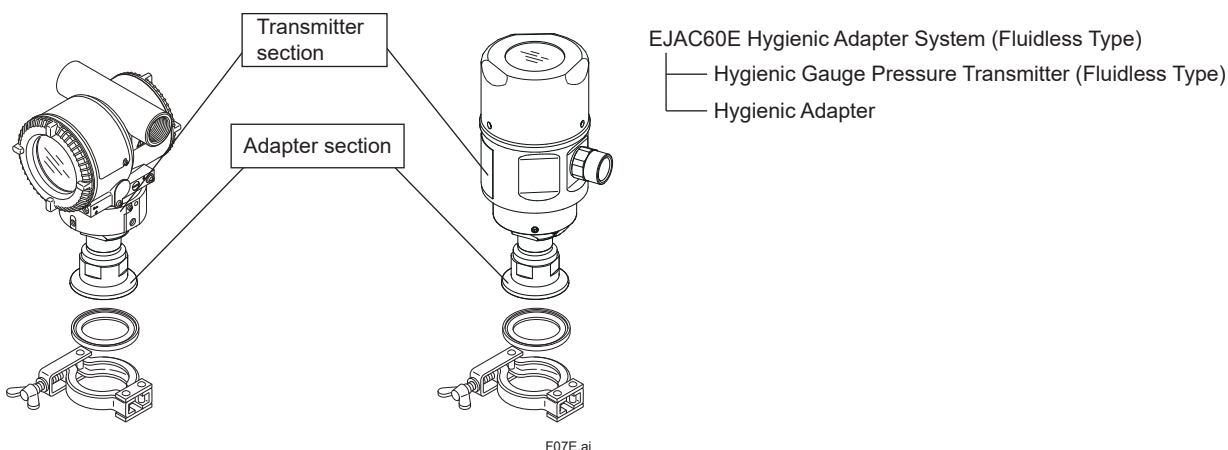

Hygienic Adapter System (Fluidless Type)

Combination Model	Suffix Codes	Description
EJAC60E	Hygienic Adapter System (Fluidless Type)
Measurement type	-G	Gauge Pressure
Style	6	Hygienic Adapter
-----	0	Always 0
Measurement Span	<input type="checkbox"/>	Select from measurement span (capsule) codes of the transmitter.(A, B or C)
Process Connection	C	Clamp connection type
	U	Union connection type
	D	In-line clamp connection type
Wetted parts	<input type="checkbox"/>	Select from wetted parts material codes of the adapter. (Wetted parts material codes: S)
-----	N	Always N
-----	N	Always N
Fill fluid	N	(None)
-----	-N	Always N
-----	N	Always N

Transmitter part
EJA560E Hygienic Gauge Pressure Transmitter (Fluidless Type)

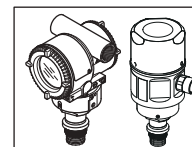

F08E.ai

Model	Suffix Codes	Description
EJA560E	Hygienic Gauge Pressure Transmitter (Fluidless Type)
Output signal	-J	4 to 20 mA DC with digital communication (HART 5 / HART 7 protocol) (Refer to GS 01C31T01-01EN)
Measurement span (capsule)	A B C	20 to 400 kPa (2.9 to 58 psi) 0.1 to 1 MPa (14.5 to 145 psi) 0.3 to 3 MPa (43.5 to 435 psi)
Wetted parts material *1*8	E	[Diaphragm] [Others] 329J4L SST *2 316L SST *3
Connection type	H	G3/4 male connection
-----	N	Always N
Wetted O-ring *5	-E -F	EPDM (Ethylene-propylene rubber) FKM (Fluoro-rubber) *4
Amplifier housing	1 5	Cast aluminum alloy Stainless steel
Electrical connection	0 2 4 5 7 9 A C D G H	G1/2 female, one electrical connection without blind plugs 1/2 NPT female, two electrical connections without blind plugs *6 M20 female, two electrical connections without blind plugs *6 G1/2 female, two electrical connections with a blind plug *6 1/2 NPT female, two electrical connections with a blind plug *6 M20 female, two electrical connections with a blind plug *6 G1/2 female, two electrical connections and a 316 SST blind plug *6 1/2 NPT female, two electrical connections and a 316 SST blind plug *6 M20 female, two electrical connections and a 316 SST blind plug *6 1/2NPT female, one electrical connection without blind plugs *7 M20 female, one electrical connection without blind plugs *7
Integral indicator	D E N	Digital indicator Digital indicator with the range setting switch (push button) (None)
-----	N	Always N
Optional Codes	/□	Optional specification

Most typical selection for each specification
 ex. EJA560E-JAEHN-E10NN/□

- *1: Users must consider the characteristics of selected wetted parts material and the influence of process fluids. The use of inappropriate materials can result in the leakage of corrosive process fluids and cause injury to personnel and/or damage to plant facilities. It is also possible that the diaphragm itself can be damaged and that material from the broken diaphragm can contaminate the user's process fluids.
 Be very careful with highly corrosive process fluids such as hydrochloric acid, sulfuric acid, hydrogen sulfide, sodium hypochlorite, and high-temperature steam (150°C [302°F] or above). Contact Yokogawa for detailed information of the wetted parts material.
- *2: Equivalent to SUS329J4L
- *3: SUS316L or ASTM grade 316L
- *4: Lower limit of ambient temperature: -20°C (-4°F)
- *5: 3-A Sanitary Certification.
- *6: Not applicable for amplifier housing code "5"
- *7: Not applicable for amplifier housing code "1"
- *8: Surface roughness for wetted part: Ra ≥ 0.8 μm

C10SA Hygienic Adapter

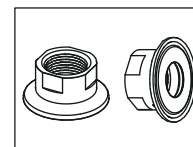

F09E.ai

Model	Suffix Codes	Description
C10SA	Hygienic Adapter
System location	-H	for high pressure side
Process Connection Style	C U D	Clamp connection Union connection In-line clamp connection
Usage	-S	for general use
-----	N	Always N
Adapter material*10	S	316L SST *1
Process Connection Standard	S D V	ISO DIN GV *5
Process Connection Size	8 7 6 2 1 3 4	[ISO type] [DIN type] [GV type] --- DIN25 DN25 --- DIN32 --- ISO25/38 (IDF1.0S/1.5S)*6 DIN40 DN40 ISO51 (IDF2.0S) DIN50 DN40/50 ISO63.5 (IDF2.5S) --- --- ISO76.1 (IDF3.0S) --- DN65/80 ISO101.6 (IDF4.0S) --- DN100
Sealing Face Option	E B C N	Electro polishing *2 Buffing *3 Electro polishing and Buffing *2*3 None
-----	N	Always N
-----	N	Always N
-----	N	Always N
-----	N	Always N
-----	N	Always N
Accessories *4*9	Connection Size -8 -7 -6 -2 -1 -3 -4 -N	[ISO type] [DIN type] ISO25 (IDF1.0S) DIN25 --- DIN32 ISO38 (IDF1.5S) DIN40 ISO51 (IDF2.0S) DIN50 ISO63.5 (IDF2.5S) --- ISO76.1 (IDF3.0S) --- ISO101.6 (IDF4S) --- None
	Standards and Connection Style C U G N	ISO2852 Clamp for Flush type (Clamp Maximum Working Pressure: 1 MPa (145 psi)) ISO2853 Coupling Nut (Maximum Working Pressure: 3 MPa (435 psi)) DIN11851 Coupling Nut (Maximum Working Pressure: 3 MPa (435 psi)) None
	-----	N Always N
	Gasket material *8 E F N	EPDM (Ethylene-propylene rubber) FKM (Fluoro-rubber) *7 None

- *1: SUS316L or ASTM grade 316L.
- *2: Electro polishing for all wetted parts.
- *3: Buffing for wetted part. (JIS-standard: #400)
- *4: Clamp and gasket are not required, all of the code are selected "N".
- *5: All the code of Clamp and gasket can be selected only "N".
- *6: The code "6" of union nut can be selected only ISO38.
- *7: Lower limit of ambient temperature: -20°C (-4°F)
- *8: 3-A sanitary standard.
- *9: Combination is listed in the accessory list.
- *10: Surface roughness for wetted part: Ra ≥ 0.8 μm

■ OPTIONAL SPECIFICATIONS

● EJAC60E Hygienic Adapter System (Fluidless Type)

Item	Description	Code
Oil-prohibited use *10	Degrease cleansing treatment	K21
	Degrease cleansing treatment	With certificates K81
Oil-prohibited use with dehydrating treatment*11	Degrease cleansing and dehydrating treatment	K25
	Degrease cleansing and dehydrating treatment	With certificates K85
Calibration certificate	Text, Traceability	L4
	Text, Traceability, Primary standards list	L5
	Text, Traceability, Primary standards list, Calibration equipment list	L6
	Text, Traceability, Primary standards list, Calibration equipment list, Calibration equipment certificate	L9

● EJA560E Hygienic Gauge Pressure Transmitter (Fluidless type)

Item	Description	Code	
Painting *8	Color change	Amplifier cover only	P□
		Amplifier cover and terminal cover, Munsell 7.5 R4/14	PR
	Coating change	Anti-corrosion coating *1	X2
316 SST exterior parts *2	316 SST zero-adjustment screw and setscrews	HC	
Fluoro-rubber O-ring *8	All O-rings of amplifier housing. Lower limit of ambient temperature: -15°C (5°F)	HE	
Oil-prohibited use	Degrease cleansing treatment	K11	
Oil-prohibited use with dehydrating treatment	Degrease cleansing and dehydrating treatment	K15	
Wired tag plate *8	316 SST tag plate wired onto transmitter	N4	
Output limits and failure operation *3	Failure alarm down-scale: Output status at CPU failure and hardware error is -5%, 3.2 mA DC or less for 4 to 20 mA output type and -5%.	C1	
	NAMUR NE43 Compliant Failure alarm down-scale: Output status at CPU failure and hardware error is -5%, 3.2 mA DC or less.	C2	
	Output signal limits: 3.8 mA to 20.5 mA Failure alarm up-scale: Output status at CPU failure and hardware error is 110%, 21.6 mA or more.	C3	
Data configuration at factory *4	Data configuration for HART communication type, Software damping, Descriptor, Message	CA	
	Data configuration for HART communication type, Software damping, Descriptor, Message, External zero adjustment prohibition setting	CJ	
Calibration units *5	P calibration (psi unit)	(See Table for Span and Range Limits.)	D1
	bar calibration (bar unit)		D3
	M calibration (kgf/cm ² unit)		D4
Material certificate	Diaphragm, Body	M16	
High-humidity environment type *7	Atmospheric release from terminal box *6 Lower limit of ambient temperature: -15°C (5°F)	HH	
Sanitary standard *9	3-A Sanitary Certification	3A	
Parameter list	List of setting and adjustment parameters	YP	

*1: Not applicable with color change option.

*2: 316 or 316L SST.

*3: The hardware error indicates faulty amplifier or capsule.

*4: Also see 'Ordering Information'.

*5: The unit of MWP (Max. working pressure) on the name plate of a housing is the same unit as specified by option codes D1, D3, and D4.

*6: When chose option code HH, the L-side hole of body is sealed with a sealing screw and the reference pressure (atmospheric pressure) is introduced from the terminal box of the amplifier housing.
In the standard specification, the reference pressure (atmospheric pressure) is introduced from the L-side hole of body.

*7: Not applicable with Electrical connection code "0" of transmitter.

*8: Not applicable for amplifier housing code 5.

*9: Not applicable with GV Clamp DN40.

*10: Applicable for combination with /K11 of EJA560E and /K31 of C10SA.

*11: Applicable for combination with /K15 of EJA560E and /K35 of C10SA.

● C10SA Hygienic Adapter

Item	Description	Code
Oil-prohibited use	Degrease cleansing treatment	K31
Oil-prohibited use with dehydrating treatment	Degrease cleansing and dehydrating treatment	K35
Material certificate	Adapter	M17
Certificate	Electro polishing	Y1
	Buffing	Y2
	Buffing and Electro polishing	Y4

Notes for Combination

Process Connection Style	Process Connection Standard	Process Connection Size
C	S	6, 2, 1, 3, 4
	V	6
U	S	6, 2
	D	8, 7, 6, 2
D	V	8, 2, 3, 4

DIMENSIONS

EJA560E Hygienic Gauge Pressure Transmitter (Fluidless Type)

Unit: mm (approx. inch)

- Cast aluminum housing

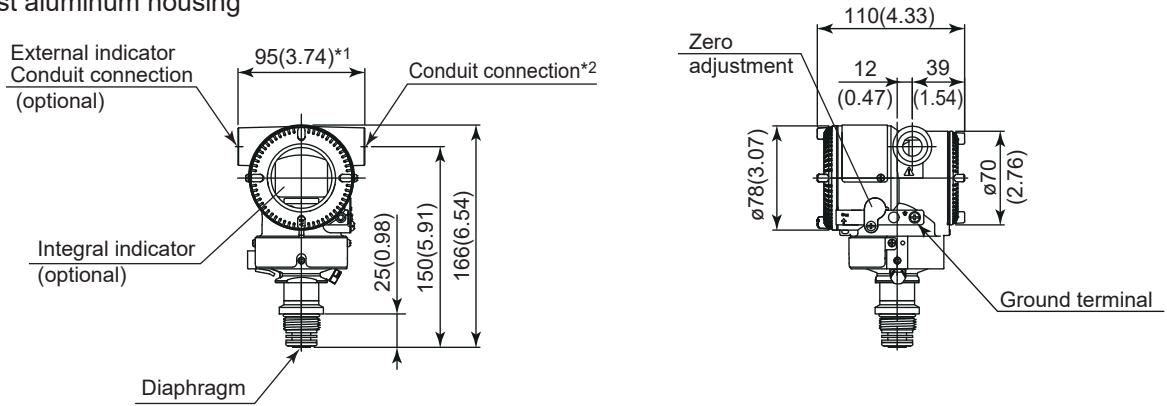

Electrical connection for code 5, 9, A, and D.

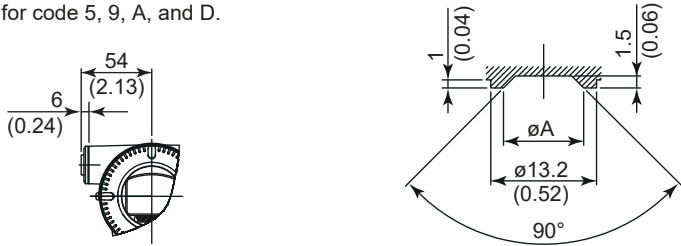

Dimensions	
Measurement span code	øA
A	10(0.39)
B, C	8(0.31)

Cross section dimensions of diaphragm

- *1: When electrical connection code 7 or C is selected, a blind plug is protruded by up to 8 mm (0.31 inch) from conduit connection.
- *2: When option code PP is selected, a blind plug is attached to the conduit connection on both sides.

- Terminal Configuration

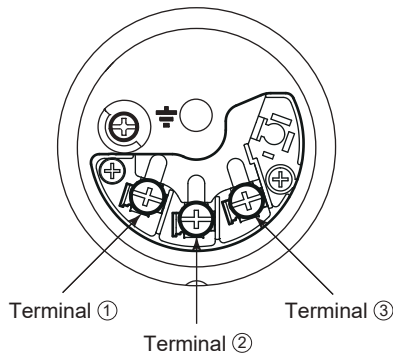

- Terminal Wiring

SUPPLY	+	①] Power supply and output terminals
	-	②	
CHECK	+	③] External indicator (ammeter) terminals*1
	-	②	
		⊥	Ground terminal

- *1: When using an external indicator or check meter, the internal resistance must be 10 Ω or less.

F10E.ai

EJA560E Hygienic Gauge Pressure Transmitter (Fluidless Type)

Unit: mm (approx. inch)

- Stainless steel housing

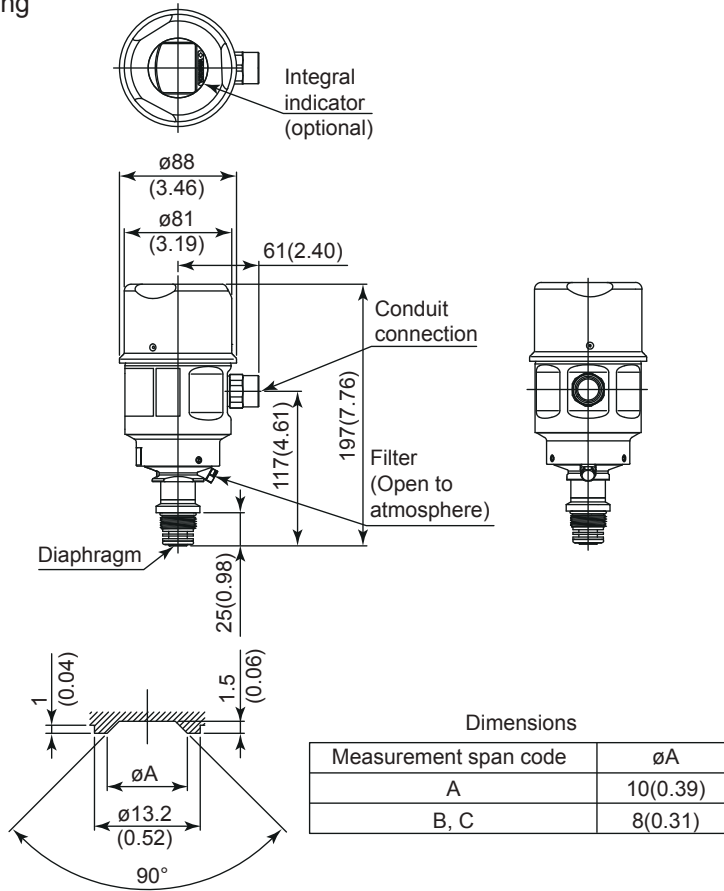

Cross section dimensions of diaphragm

- Terminal Configuration

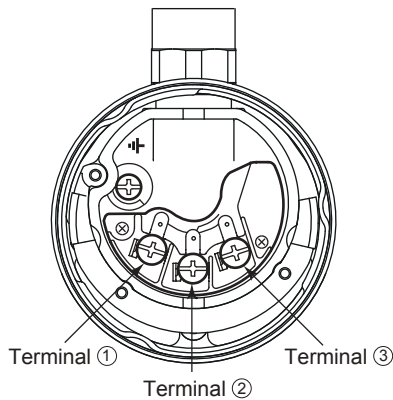

- Terminal Wiring

SUPPLY	+	①] Power supply and output terminals
	-	②	
CHECK	+	③] External indicator (ammeter) terminals*1
	-	②	
		⏏	Ground terminal

*1: When using an external indicator or check meter, the internal resistance must be 10 Ω or less.

F11E.ai

C10SA Hygienic Adapter

Unit: mm (approx. inch)

• **ISO 2852 Clamp Connection**

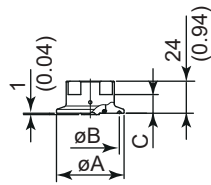
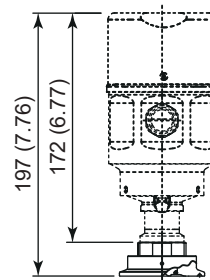
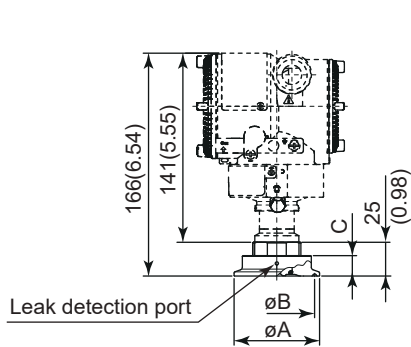

Process connection size for code 6

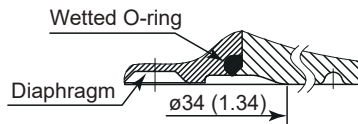

Enlarged view of wetted O-ring area except for code 6

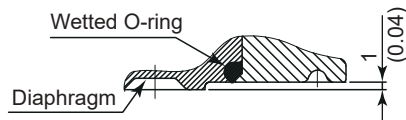

Enlarged view of wetted O-ring area for code 6

F12E.ai

	Code	Adapter size	ϕA	ϕB	C
ISO 2852 Clamp Connection	6	ISO25/38	50.5 (1.99)	43.5 (1.71)	14 (0.55)
	2	ISO51	64 (2.52)	56.5 (2.22)	15.2 (0.60)
	1	ISO63.5	77.5 (3.05)	70.5 (2.78)	15.2 (0.60)
	3	ISO76.1	91 (3.58)	83.5 (3.29)	20 (0.79)
	4	ISO101.6	119 (4.69)	110 (4.33)	20 (0.79)

Unit: mm (approx. inch)

• ISO 2853 Union Connection

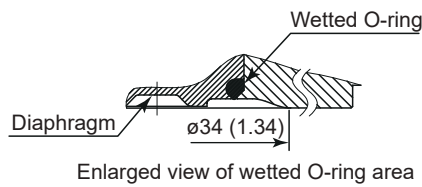
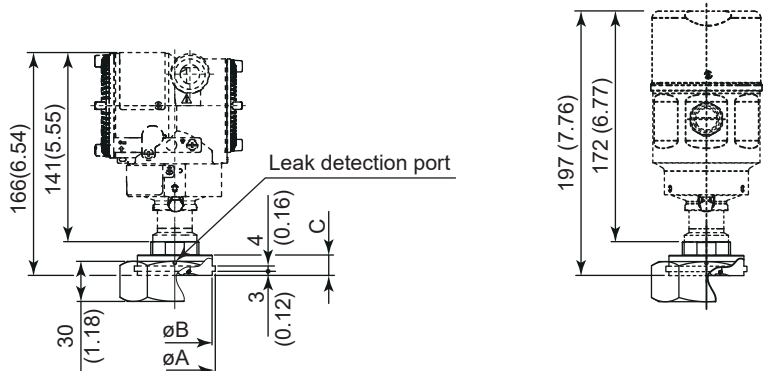

F13E.ai

	Code	Adapter size	øA	øB	C
ISO 2853 Union Connection	6	ISO38	47 (1.85)	42.5 (1.67)	15.2 (0.60)
	2	ISO51	60.5 (2.38)	56.0 (2.20)	15.2 (0.60)

Unit: mm (approx. inch)

• DIN 11851 Union Connection

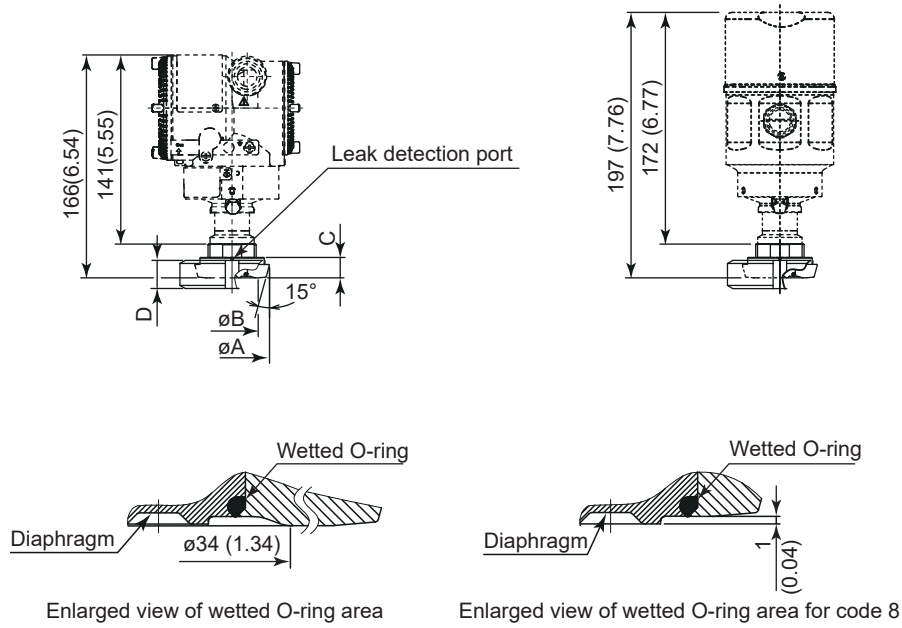

F14E.ai

	Code	Adapter size	øA	øB	C	D
DIN 11851 Union Connection	8	DN25	44 (1.73)	27.5 (1.08)	14 (0.55)	21 (0.83)
	7	DN32	50 (1.97)	33 (1.30)	15.2 (0.60)	21 (0.83)
	6	DN40	56 (2.20)	39 (1.54)	15.2 (0.60)	21 (0.83)
	2	DN50	68.5 (2.70)	51 (2.01)	15.2 (0.60)	22 (0.87)

Unit: mm (approx. inch)

• **GV In-line Clamp Connection**

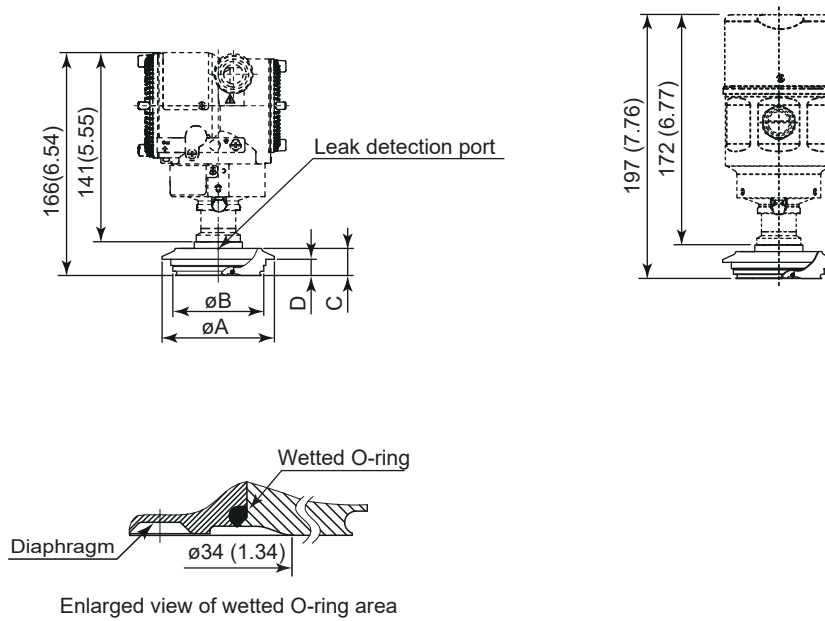

F15E.ai

	Code	Adapter size	ϕA	ϕB	C	D
GV In-line Clamp Connection	8	DN25	66 (2.60)	50 (1.97)	15.2 (0.60)	9.5 (0.37)
	2	DN40/50	84 (3.31)	68 (2.68)	20.2 (0.80)	12.1 (0.48)
	3	DN65/80	115 (4.53)	94.9 (3.74)	22 (0.87)	15.2 (0.60)
	4	DN100	142 (5.59)	122.9 (4.84)	21.8 (0.86)	15.2 (0.60)

Unit: mm (approx. inch)

● **GV Clamp Connection**

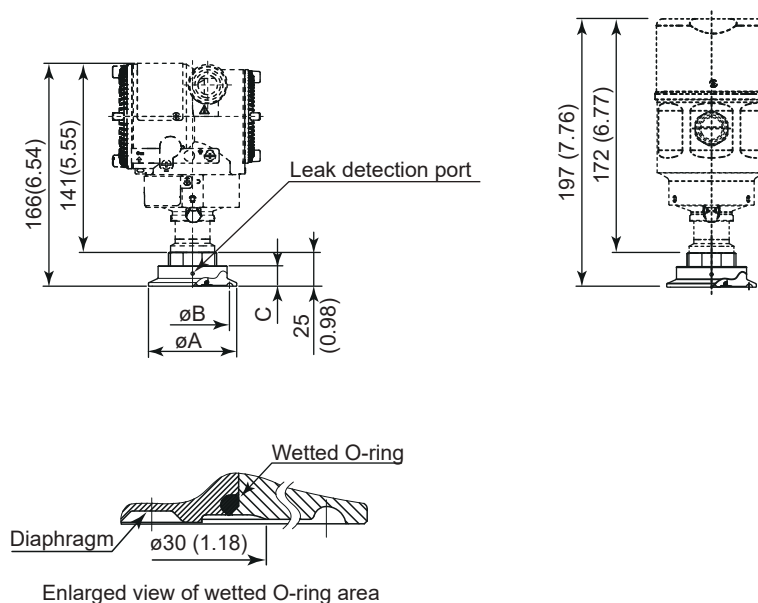

F16E.ai

	Code	Adapter size	øA	øB	C
GV Clamp Connection	6	DN40	66 (2.60)	55.2 (2.17)	15.2 (0.60)

● **Accessory list**

Adapter Style	Adapter Size	Accessory		
		Clamp / Coupling Nut	Gasket (3A)	
			EPDM	FKM
ISO 2852 Clamp	ISO25/38	ISO25/38 Clamp	ISO25 ISO38	ISO25 ISO38
	ISO51	ISO51 Clamp	ISO51	*
	ISO63.5	ISO63.5 Clamp	ISO63.5	*
	ISO76.1	ISO76.1 Clamp	ISO76.1	*
	ISO101.6	ISO101.6 Clamp	ISO101.6	*
ISO 2853 Union	ISO38	ISO38 Coupling Nut	*	*
	ISO51	ISO51 Coupling Nut	*	*
DIN 11851 Union	DIN DN25	DIN DN25 Coupling Nut	*	*
	DIN DN32	DIN DN32 Coupling Nut	*	*
	DIN DN40	DIN DN40 Coupling Nut	*	*
	DIN DN50	DIN DN50 Coupling Nut	*	*
GV In-line Clamp	GV DN25	*	*	*
	GV DN40/50	*	*	*
	GV DN65/80	*	*	*
	GV DN100	*	*	*
GV Clamp	GV DN40	*	*	*

*: We do not stock that product.
This should be prepared by users.

< Ordering Information >

Specify the following when ordering

1. Model, suffix codes, and option codes
2. Calibration range and units
 - 1) Calibration range can be specified with range value specifications up to 5 digits (excluding any decimal point) for low or high range limits within the range of -32000 to 32000. When reverse range is designated, specify Lower Range Value (LRV) as greater than Upper Range Value (URV).
 - 2) Specify only one unit from the table, 'Factory Settings' when shipped.'
3. Display scale and units (for transmitters equipped with integral indicator only)

Specify either 0 to 100 % or engineering unit scale and 'Range and Unit' for engineering units scale: Scale range can be specified with range limit specifications up to 5 digits (excluding any decimal point) for low or high range limits within the range of -32000 to 32000. The unit display consists of 6-digit, therefore, if the specified unit is longer than 7 characters excluding '/', the first 6 characters will be displayed on the unit display.
4. HART PROTOCOL

Specify the HART protocol revision "5" or "7".
5. TAG NO (if required)

Specified characters (up to 22 characters or 16 characters for /N4 tag) are engraved on the stainless steel tag plate or polyester label fixed on the housing.
6. SOFTWARE TAG (if required)

Specified characters (up to 32 characters) are set as "Tag" (the first 8 characters) and "Long tag"*1 (32 characters) in the amplifier memory. Use alphanumeric capital letters.

When the "SOFTWARE TAG" is not specified, specified "TAG NO" is set as "Tag" (the first 8 characters) and "Long tag"*1 (22 characters) in the amplifier memory.

*1: applicable only when HART 7 is selected.
7. Other factory configurations (if required)

Specifying option code /CA or /CJ will allow further configuration at factory. Following are configurable items and setting range.

 - 1) Descriptor (up to 16 characters)
 - 2) Message (up to 30 characters)
 - 3) Software damping in second (0.00 to 100.00)

< Factory Setting >

Tag number	As specified in order
Software damping*1	'2.00 s' or as specified in order
Calibration range lower range value	As specified in order
Calibration range upper range value	As specified in order
Calibration range units	Selected from mmH ₂ O, mmH ₂ O(68°F), mmHg, Pa, hPa, kPa, MPa, mbar, bar, gf/cm ² , kgf/cm ² , inH ₂ O, inH ₂ O(68°F), inHg, ftH ₂ O, ftH ₂ O(68°F) or psi. (Only one unit can be specified)
Display setting	Designated value specified in order.(%, or user scaled value.)

*1: To specify these items at factory, /CA or /CJ is required.

< Information on EU WEEE Directive >

EU WEEE (Waste Electrical and Electronic Equipment) Directive is only valid in the EU. This instrument is intended to be sold and used only as a part of equipment which is excluded from WEEE Directive, such as large-scale stationary industrial tools, a large-scale fixed installation and so on, and, therefore, subjected to the exclusion from the scope of the WEEE Directive. The instrument should be disposed of in accordance with local and national legislation/regulations.