

Technical Information

STT 3000 Smart Temperature Transmitter Series STT170 Specifications

Model STT171, STT173, STT17H, STT17C

34-TT-03-07, May 2023



Overview

The Honeywell STT170 series of programmable temperature transmitters provide cost-effective solutions for temperature monitoring applications. Compared to direct-wired temperature sensor monitoring points, the STT170 series of transmitters delivers increased accuracy, safety and reliability while also reducing wiring costs. These transmitters automatically linearize the temperature output signal bounded by the upper range value and lower range value established by the user. In addition, the user can program high or low limit alarms to activate in the case of sensor failure.

STT171 Features

- Analog 4-20 mA output.
- RTD or Ohm input.
- DIN form B head mount.
- NAMUR NE43 sensor error response.
- Configurable using STT17C configuration tool and PC.

STT173 Features

- Analog 4-20 mA output
- RTD, T/C, Ohm or mV input
- DIN form B head mount
- NAMUR NE43 sensor error response
- Configurable using STT17C configuration tool and PC
- Galvanic isolation



Figure 1– SmartLine STT 3000 Temperature transmitter

STT17H Features

- HART™/4-20 mA output
- RTD, T/C, Ohm or mV input
- Single or dual (difference or average) sensor input
- DIN form B head mount
- HART Multidrop capable
- NAMUR NE43 sensor error response



Dimensions (all models)

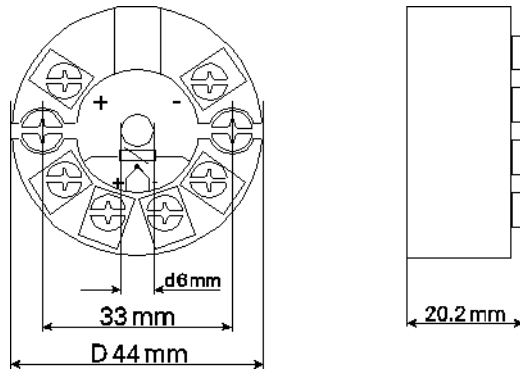

Wiring

STT171

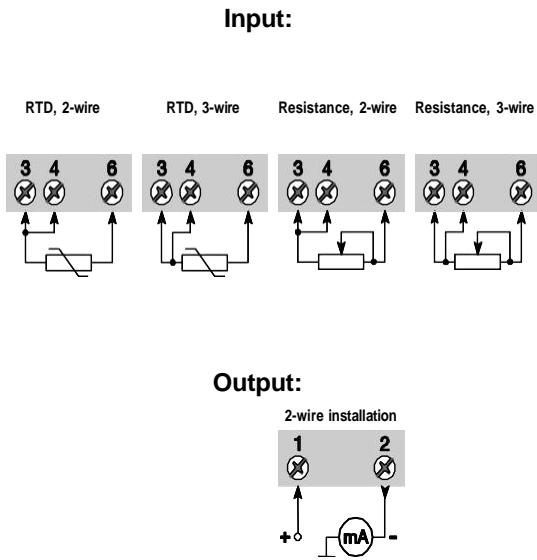

STT173

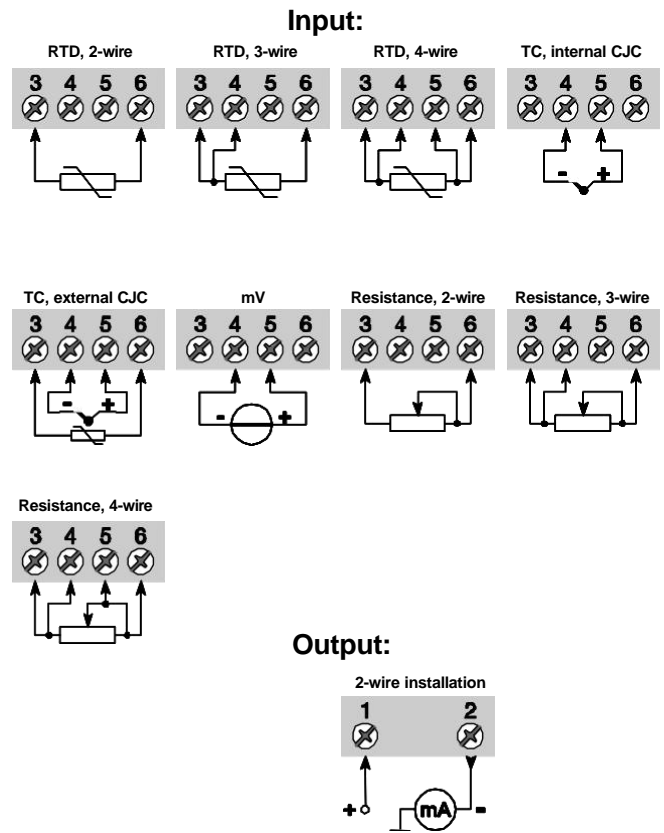

STT17H

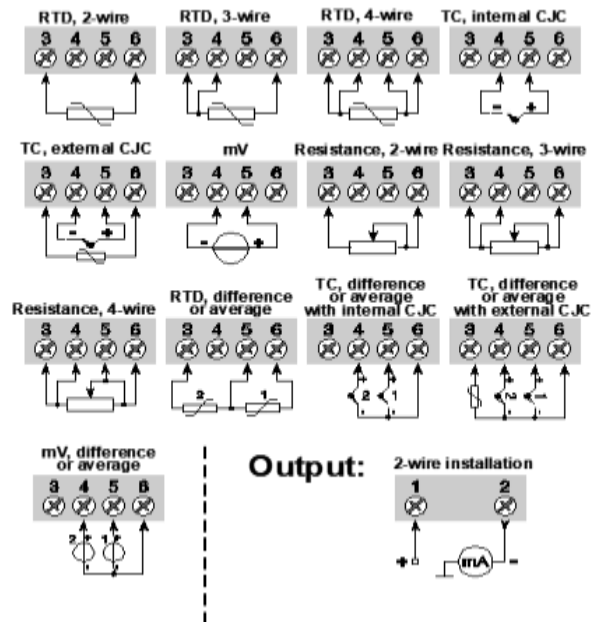
Input:

STT17C Configuration tool

The STT17C configures the STT171, STT173 and STT17H. The intuitive graphical user interface of the STT17C virtually eliminates the need for operator training after installation on a PC. The STT17C includes all software and transmitter interface hardware necessary to configure the STT171, STT173 and STT17H in non-hazardous work environments.

WARNING: The STT17C is not approved for use in Hazardous work environments.

System Requirements:

Windows® 98SE, ME, 2000 and XP with the following recommendations:

Memory: 16 MB

Display resolution: 800 x 600

Hard disk space: 12 MB

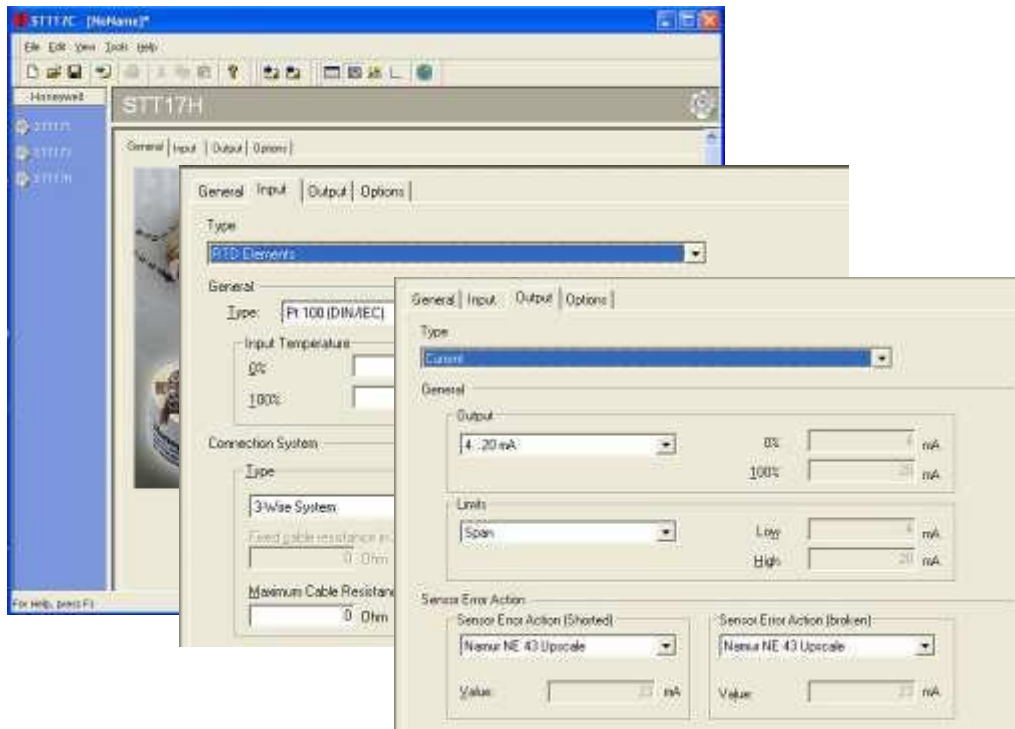
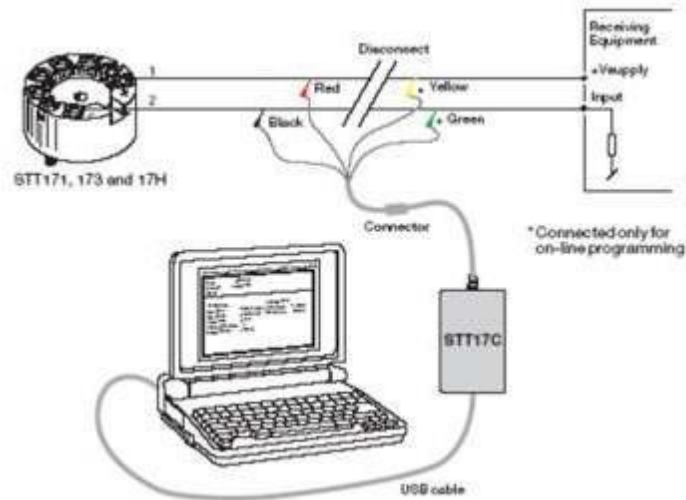

STT171-BS Specifications

Sensor Type	Basic Accuracy*		Rated Range		Standards	Minimum Span**	Temperature Effects per 1.0°C (1.8°F) Change in Ambient Temperature***	
	Fixed	% of Span	°C	°F			Fixed	% of Span
Pt100	0.3°C (0.54°F)	± 0.1	-200 to 850	-328 to 1562	IEC60751	25°C (45°F)	0.01°C (0.018°F)	±0.01
Ni100	0.3°C (0.54°F)	± 0.1	-60 to 250	-76 to 482	DIN 43760	25°C (45°F)	0.01°C (0.018°F)	±0.01
o	0.2 o	± 0.1	0 to 10000 o			30 o	20 mo	±0.01

*whichever is greater; Total Reference Accuracy = Basic Accuracy

**or 50% of upper range value, whichever is greater

*** reference temperature 24°C

OPERATING CONDITIONS

Ambient temperature, rated.....-40 to 85°C (-40 to 185°F)
Humidity.....0 to 95% RH (non-cond.)
Vibration.....Max 4g over 25 to 100Hz

ELECTRICAL INPUT SPECIFICATIONS

Supply voltage.....8 to 30 VDC
Power supply voltage effect..... ≤ 0.005% of span per VDC
Warm-up time..... 5 min
Response time (programmable)..... 0.33 to 60 sec

CURRENT OUTPUT SPECIFICATIONS

Signal output range.....4 to 20 mA
Update time..... 135 msec
Load resistance..... ≤(V supply - 8) / 0.023 A
0 to 870 o

ALARM LEVELS

Programmable..... 3.5 to 4 mA downscale
20 to 23 mA upscale
NAMUR NE43 Upscale.....23 mA
NAMUR NE43 Downscale..... 3.5 mA

APPROVALS

Observed Authority requirements: Standard:
EMC 2004/108/EC
Emmission and immunity EN 61326
ATEX 94/9/EC..... EN 50014, EN 50020,
EN 50281 1-1 and EN 50284
FM, ASCN.....3600, 3611, 3610
CSA, CAN / CSAC22.2 No. 157, E60079-11,
UL 913
Ex / I.S. approval:
KEMA 06 ATEX 0042 X.....  II 1 GD, T80°C...T105°C
EEx ia IIC T4, T6
Max. amb. Temperature for T4..... 85°C
Max. amb. Temperature for T6..... 60°C
Applicable in zone..... 0, 1, 2, 20, 21 or 22
FM, applicable in..... IS, CL I, DIV 1, Grp. A-D, T4...T6
AEx ia IIC
NI, CL I, DIV 2, Grp. A-D, T4...T6
Entity, FM Installation Drawing No..... 50016324
CSA, applicable in..... IS, CL I, DIV 1, Grp. A-D, T4...T6
Ex ia IIC, AEx ia IIC
Entity, Installation Drawing No..... 50016326

Ex / I.S. data:

U_i (max) 30 VDC
I_i (max)..... 120 mADC
P_i (max) 0.84 W
L_i (max)..... 10 µH
C_i (max) 1.0 nF
U_o (max) 27 VDC
I_o (max)..... 7 mADC
P_o (max)..... 45 m W
L_o (max) 35 mH
C_o (max) 90 nF

STT173-BS Specifications

Sensor Type	Basic Accuracy*		Rated Range		Standards	Minimum Span**	Temperature Effects per 1.0°C (1.8°F) Change in Ambient Temperature***	
	Fixed	% of Span	°C	°F			Fixed	% of Span
PT100	0.2°C (0.36°F)	± 0.1	-200 to +850	-328 to +1562	IEC60751	25°C (45°F)	0.01°C (0.018°F)	±0.01
NI100	0.2°C (0.36°F)	± 0.1	-60 to +250	-76 to +482	DIN 43760	25°C (45°F)	0.01°C (0.018°F)	±0.01
B	2°C (3.6°F)	± 0.1	+400 to +1820	+752 to +3308	IEC584	200°C (360°F)	0.2°C (0.36°F)	±0.01
E	1°C (1.8°F)	± 0.1	-100 to +1000	-148 to +1832	IEC584	50°C (90°F)	0.05°C (0.09°F)	±0.01
J	1°C (1.8°F)	± 0.1	-100 to +1200	-148 to +2192	IEC584	50°C (90°F)	0.05°C (0.09°F)	±0.01
K	1°C (1.8°F)	± 0.1	-180 to +1372	-192 to +2502	IEC584	50°C (90°F)	0.05°C (0.09°F)	±0.01
L	1°C (1.8°F)	± 0.1	-100 to +900	-148 to +1652	DIN 43710	50°C (90°F)	0.05°C (0.09°F)	±0.01
N	1°C (1.8°F)	± 0.1	-180 to +1300	-292 to +2372	IEC584	100°C (180°F)	0.05°C (0.09°F)	±0.01
R	2°C (3.6°F)	± 0.1	-50 to +1760	-58 to +3200	IEC584	200°C (360°F)	0.2°C (0.36°F)	±0.01
S	2°C (3.6°F)	± 0.1	-50 to +1760	-58 to +3200	IEC584	200°C (360°F)	0.2°C (0.36°F)	±0.01
T	1°C (1.8°F)	± 0.1	-200 to +400	-328 to +752	IEC584	50°C (90°F)	0.05°C (0.09°F)	±0.01
U	1°C (1.8°F)	± 0.1	-200 to +600	-328 to +1112	DIN 43710	75°C (135°F)	0.05°C (0.09°F)	±0.01
W3	2°C (3.6°F)	± 0.1	0 to +2300	+32 to +4172	ASTM E988-90	200°C (360°F)	0.2°C (0.36°F)	±0.01
W5	2°C (3.6°F)	± 0.1	0 to +2300	+32 to +4172	ASTM E988-90	200°C (360°F)	0.2°C (0.36°F)	±0.01
Ω	0.1 Ω	± 0.1	0 to 5000 Ω			30 Ω	10 mΩ	±0.01
mV	10 μV	± 0.1	-12 to 800 mV			5 mV	1 μV	±0.01

*whichever is greater; Total Reference Accuracy = Basic Accuracy + CJ Accuracy (T/C only)

** or 50% of upper range value, whichever is greater

*** reference temperature 24°C

OPERATING CONDITIONS

Ambient temperature, rated	-40 to 85°C (-40 to 185°F)
Humidity	0 to 95% RH (non-cond.)
Vibration	Max 4g over 25 to 100Hz
Cold junction accuracy	±1.0°C

ELECTRICAL INPUT SPECIFICATIONS

Supply voltage	7.2 to 30 VDC
Power supply voltage effect	≤ 0.005% of span per VDC
Warm-up time	5 min
Response time (programmable)	1 to 60 sec
Galvanic isolation	1500 VAC

CURRENT OUTPUT SPECIFICATIONS

Signal output range	4 to 20 mA
Update time	440 msec
Load resistance (Ω)	≤ (V supply - 7.2) / 0.023 A 0 to 904 Ω

ALARM LEVELS

Programmable	3.5 to 4 mA downscale 20 to 23 mA upscale
NAMUR NE43 Upscale	23 mA
NAMUR NE43 Downscale	3.5 mA

APPROVALS

Observed Authority requirements:

EMC 2004/108/EC	Standard:
Emmission and immunity	EN 61326
ATEX 94/9/EC	EN 50014, EN 50020
FM, ASCN	3600, 3611, 3610
CSA, CAN / CSA	C22.2 No. 157, E60079-11, UL 913

Ex / I.S. approval:

KEMA 06 ATEX 0063 X	Ex II 1 GD, T80°C...T105°C EEx ia IIC T4...T6
Max. amb. Temperature for T4	85°C
Max. amb. Temperature for T6	60°C
Applicable in zone	0, 1, 2, 20, 21 and 22

FM, applicable in	IS, CL I, DIV 1, Grp. A-D, T4...T6 AEx ia IIC
Entity, FM Installation Drawing No	NI, CL I, DIV 2, Grp. A-D, T4...T6 50016324
CSA, applicable in	IS, CL I, DIV 1, Grp. A-D, T4...T6 Ex ia IIC, AEx ia IIC
Entity, Installation Drawing No	50016326

Ex / I.S. data:

U _i (max)	30 VDC
I _i (max)	1.20 mADC
P _i (max)	0.84 W
L _i (max)	10 μH
C _i (max)	1.0 nF
U _o (max)	9.6 VDC
I _o (max)	25 mADC
P _o (max)	60 mW
L _o (max)	33 mH
C _o (max)	3.6 μF

STT17H-BS Specifications

Sensor Type	Basic Accuracy*		Rated Range		Standards	Minimum Span**	Temperature Effects per 1.0°C (1.8°F) Change in Ambient Temperature***	
	Fixed	% of Span	°C	°F			Fixed	% of Span
Pt100	0.2°C (0.36°F)	± 0.1	-200 to +850	-328 to +1562	IEC60751	10°C (18°F)	0.01°C (0.018°F)	±0.01
Pt1000	0.2°C (0.36°F)	± 0.1	-200 to +850	-328 to +1562	IEC60751	10°C (18°F)	0.01°C (0.018°F)	±0.01
Ni100	0.3°C (0.54°F)	± 0.1	-60 to +250	-76 to +482	DIN 43760	10°C (18°F)	0.01°C (0.018°F)	±0.01
B	1°C (1.8°F)	± 0.1	+400 to +1820	+752 to +3308	IEC584	100°C (180°F)	0.2°C (0.36°F)	±0.01
E	0.5°C (0.9°F)	± 0.1	-100 to +1000	-148 to +1832	IEC584	50°C (90°F)	0.05°C (0.09°F)	±0.01
J	0.5°C (0.9°F)	± 0.1	-100 to +1200	-148 to +2192	IEC584	50°C (90°F)	0.05°C (0.09°F)	±0.01
K	0.5°C (0.9°F)	± 0.1	-180 to +1372	-192 to +2502	IEC584	50°C (90°F)	0.05°C (0.09°F)	±0.01
L	0.5°C (0.9°F)	± 0.1	-100 to +900	-148 to +1652	DIN 43710	50°C (90°F)	0.05°C (0.09°F)	±0.01
N	0.5°C (0.9°F)	± 0.1	-180 to +1300	-292 to +2372	IEC584	50°C (90°F)	0.05°C (0.09°F)	±0.01
R	1°C (1.8°F)	± 0.1	-50 to +1760	-58 to +3200	IEC584	100°C (180°F)	0.2°C (0.36°F)	±0.01
S	1°C (1.8°F)	± 0.1	-50 to +1760	-58 to +3200	IEC584	100°C (180°F)	0.2°C (0.36°F)	±0.01
T	0.5°C (0.9°F)	± 0.1	-200 to +400	-328 to +752	IEC584	50°C (90°F)	0.05°C (0.09°F)	±0.01
U	0.5°C (0.9°F)	± 0.1	-200 to +600	-328 to +1112	DIN 43710	50°C (90°F)	0.05°C (0.09°F)	±0.01
W3	1°C (1.8°F)	± 0.1	0 to +2300	+32 to +4172	ASTM E988-90	100°C (180°F)	0.2°C (0.36°F)	±0.01
W5	1°C (1.8°F)	± 0.1	0 to +2300	+32 to +4172	ASTM E988-90	100°C (180°F)	0.2°C (0.36°F)	±0.01
Ω	0.1 Ω	± 0.1	0 to 7000 Ω			25 Ω	5 mΩ	±0.01
mV	10 μV	± 0.1	-800 to 800 mV			5 mV	0.5 μV	±0.01

*whichever is greater; Total Reference Accuracy = Basic Accuracy + CJ Accuracy (T/C only)

** or 50% of upper range value, whichever is greater

*** reference temperature 24°C

OPERATING CONDITIONS

Ambient temperature, rated.....	-40 to 85°C (-40 to 185°F)
Humidity.....	0 to 95% RH (non-cond.)
Vibration.....	Max 4g over 25 to 100Hz
Cold junction accuracy.....	±1.0°C

ELECTRICAL INPUT SPECIFICATIONS

Supply Voltage.....	8 to 30 VDC
Power supply voltage effect.....	≤ 0.005% of span per VDC
Warm-up time.....	30 sec
Response time (programmable).....	1 to 60 sec
Galvanic isolation.....	1500 VAC

CURRENT OUTPUT SPECIFICATIONS

Signal output range.....	4 to 20 mA
Update time.....	440 msec
Load resistance (Ω).....	≤ (V supply - 8) / 0.023 A 0 to 870 Ω

ALARM LEVELS

Programmable.....	3.5 to 4 mA downscale 20 to 23 mA upscale
NAMUR NE43 Upscale.....	23 mA
NAMUR NE43 Downscale.....	3.5 mA

APPROVALS

Observed Authority requirements:

EMC 2004/108/EC	Standard:
ATEX 94/9/EC.....	EN 61326
FM, ASCN.....	EN 50014, EN 50020, EN 50281-1-1 and EN 50284
CSA, CAN / CSA.....	3600, 3611, 3610 C22.2 No. 157, E60079-11, UL 913

Ex / I.S. approval:

KEMA 06 ATEX 0044 X.....	Ex II 1 GD, T80°C...T105°C EEx ia IIC T4...T6
Max. amb. Temperature for T4.....	85°C
Max. amb. Temperature for T6.....	60°C
Applicable in zone.....	0, 1, 2, 20, 21 or 22

FM, applicable in.....	IS, CL I, DIV 1, Grp. A-D, T4...T6 AEx ia IIC NI, CL I, DIV 2, Grp. A-D, T4...T6
Entity, FM Installation Drawing No.....	50016324
CSA, applicable in.....	IS, CL I, DIV 1, Grp. A-D, T4...T6 Ex ia IIC, AEx ia IIC
Entity, Installation Drawing No.....	50016326

Ex / I.S. data:

U _i (max).....	30 VDC
I _i (max).....	120 mADC
P _i (max).....	0.84 W
L _i (max).....	10 μH
C _i (max).....	1.0 nF
U _o (max).....	9.6 VDC
I _o (max).....	28 mADC
P _o (max).....	67 mW
L _o (max).....	33 mH
C _o (max).....	3.5 μF

STT17H-BN Specification

Sensor Type	Basic Accuracy*		Rated Range		Standards	Minimum Span**	Temperature Effects per 1.0°C (1.8°F) Change in Ambient Temperature***	
	Fixed	% of Span	°C	°F			Fixed	% of Span
Pt100	0.2°C (0.36°F)	± 0.1	-200 to +850	-328 to +1562	IEC60751	10°C (18°F)	0.01°C (0.018°F)	±0.01
Pt1000	0.2°C (0.36°F)	± 0.1	-200 to +850	-328 to +1562	IEC60751	10°C (18°F)	0.01°C (0.018°F)	±0.01
Ni100	0.3°C (0.54°F)	± 0.1	-60 to +250	-76 to +482	DIN 43760	10°C (18°F)	0.01°C (0.018°F)	±0.01
B	1°C (1.8°F)	± 0.1	+400 to +1820	+752 to +3308	IEC584	100°C (180°F)	0.2°C (0.36°F)	±0.01
E	0.5°C (0.9°F)	± 0.1	-100 to +1000	-148 to +1832	IEC584	50°C (90°F)	0.05°C (0.09°F)	±0.01
J	0.5°C (0.9°F)	± 0.1	-100 to +1200	-148 to +2192	IEC584	50°C (90°F)	0.05°C (0.09°F)	±0.01
K	0.5°C (0.9°F)	± 0.1	-180 to +1372	-192 to +2502	IEC584	50°C (90°F)	0.05°C (0.09°F)	±0.01
L	0.5°C (0.9°F)	± 0.1	-100 to +900	-148 to +1652	DIN 43710	50°C (90°F)	0.05°C (0.09°F)	±0.01
N	0.5°C (0.9°F)	± 0.1	-180 to +1300	-292 to +2372	IEC584	50°C (90°F)	0.05°C (0.09°F)	±0.01
R	1°C (1.8°F)	± 0.1	-50 to +1760	-58 to +3200	IEC584	100°C (180°F)	0.2°C (0.36°F)	±0.01
S	1°C (1.8°F)	± 0.1	-50 to +1760	-58 to +3200	IEC584	100°C (180°F)	0.2°C (0.36°F)	±0.01
T	0.5°C (0.9°F)	± 0.1	-200 to +400	-328 to +752	IEC584	50°C (90°F)	0.05°C (0.09°F)	±0.01
U	0.5°C (0.9°F)	± 0.1	-200 to +600	-328 to +1112	DIN 43710	50°C (90°F)	0.05°C (0.09°F)	±0.01
W3	1°C (1.8°F)	± 0.1	0 to +2300	+32 to +4172	ASTM E988-90	100°C (180°F)	0.2°C (0.36°F)	±0.01
W5	1°C (1.8°F)	± 0.1	0 to +2300	+32 to +4172	ASTM E988-90	100°C (180°F)	0.2°C (0.36°F)	±0.01
v	0.1 v	± 0.1	0 to 7000 v			25 v	5 mv	±0.01
mV	10 µV	± 0.1	-800 to 800 mV			5 mV	0.5 µV	±0.01

*whichever is greater; Total Reference Accuracy = Basic Accuracy + CJ Accuracy (T/C only)

**or 50% of upper range value, whichever is greater

*** reference temperature 24°C

OPERATING CONDITIONS

Ambient temperature, rated..... -40 to 85°C (-40 to 185°F)
 Humidity..... 0 to 95% RH (non-cond.)
 Vibration..... Max 4g over 25 to 100Hz
 Cold junction accuracy..... ±1.0°C

ELECTRICAL INPUT SPECIFICATIONS

Supply Voltage..... 8 to 35 VDC
 Power supply voltage effect..... ≤ 0.005% of span per VDC
 Warm-up time..... 30 sec
 Response time (programmable)..... 1 to 60 sec
 Galvanic isolation..... 1500 VAC

CURRENT OUTPUT SPECIFICATIONS

Signal output range..... 4 to 20 mA
 Update time..... 440 msec
 Load resistance (v)..... ≤(V supply - 8) / 0.023 A
 0 to 1174 v

ALARM LEVELS

Programmable..... 3.5 to 4 mA downscale
 20 to 23 mA upscale
 NAMUR NE43 Upscale..... 23 mA
 NAMUR NE43 Downscale..... 3.5 mA

APPROVALS

Observed Authority requirements: **Standard:**
 EMC 2004/108/EC
 Emmission and immunity EN 61326
 ATEX 94/9/EC..... EN 60079-0, EN 60079-15

Ex / I.S. approval:

KEMA 06 ATEX 0043 X.....  II 3 GD, T80°C...T105°C
 EEx nA [L] IIC T4. T6
 Applicable in zone..... 2
 Max. amb. Temperature for T4..... 85°C
 Max. amb. Temperature for T6..... 60°C

Vmax..... V

STT171 Custom Configuration Data Sheet

Customer P.O. Number _____

Line Item _____

Model Number _____

Tag Number (max 15 char) _____

Honeywell Sales Order Number _____

Sensor Type:

- Pt100
- Ni100
- Ohms

Output Values:

4 mA Value:

 _____ °C _____ °F _____ Ohms

20 mA Value:

 _____ °C _____ °F _____ Ohms

Response time:

(0.33 – 60 sec)

Output Limits:

- Span (4 to 20 mA)
- Max (3.5 to 23 mA)
- Specify Low _____ mA, High _____ mA
- NAMUR NE 43 (3.8 to 20.5 mA)

Sensor Error Action:

- Off
- Specify _____ mA
- NAMUR NE 43 upscale (23 mA)
- NAMUR NE 43 downscale (3.5 mA)

STT173 Custom Configuration Data Sheet

Customer P.O. Number _____

Line Item _____

Model Number _____

Tag Number (max 15 char) _____

Honeywell Sales Order Number _____

Sensor Type:

- Pt100
- Ni100

Wiring:

- 2-wire
- 3-wire
- 4-wire

- Ohms
- mV

- Type B T/C
- Type E T/C
- Type J T/C
- Type K T/C
- Type L T/C
- Type N T/C
- Type R T/C
- Type S T/C
- Type T T/C
- Type U T/C
- Type W3 T/C
- Type W5 T/C

Cold Junction Compensation:

- Internal
- External / Pt100
- External / Ni100

Output Values:

4 mA Value:

- _____ °C
- _____ °F
- _____ mV
- _____ Ohms

20 mA Value:

- _____ °C
- _____ °
- _____ mV
- _____ Ohms

Response time:

_____ (1 – 60 sec)

Output Limits:

- Span (4 to 20 mA)
- Max (3.5 to 23 mA)
- Specify Low _____ mA, High _____ mA
- NAMUR NE 43 (3.8 to 20.5 mA)

Sensor Error Action:

- Off
- Specify _____ mA
- NAMUR NE 43 upscale (23 mA)
- NAMUR NE 43 downscale (3.5 mA)

STT17H Custom Configuration Data Sheet

Customer P.O. Number _____

Line Item _____

Model Number _____

Tag Number (max 15 char) _____

Honeywell Sales Order Number _____

Sensor Input:

- Single Sensor
- Duplex Sensor (Average)
- Duplex Sensor (Differential)

Sensor Type:

- | | |
|---------------------------------|--------------------------------------|
| <input type="checkbox"/> Pt100 | <input type="checkbox"/> Type B T/C |
| <input type="checkbox"/> Ni100 | <input type="checkbox"/> Type E T/C |
| | <input type="checkbox"/> Type J T/C |
| | <input type="checkbox"/> Type K T/C |
| Wiring: | <input type="checkbox"/> Type L T/C |
| <input type="checkbox"/> 2-wire | <input type="checkbox"/> Type N T/C |
| <input type="checkbox"/> 3-wire | <input type="checkbox"/> Type R T/C |
| <input type="checkbox"/> 4-wire | <input type="checkbox"/> Type S T/C |
| <input type="checkbox"/> Ohms | <input type="checkbox"/> Type T T/C |
| <input type="checkbox"/> mV | <input type="checkbox"/> Type U T/C |
| | <input type="checkbox"/> Type W3 T/C |
| | <input type="checkbox"/> Type W5 T/C |

Cold Junction Compensation:

- Internal
- External / Pt100
- External / Ni100

Output Values:

4 mA Value:

- _____ °C
- _____ °F
- _____ mV
- _____ Ohms

20 mA Value:

- _____ °C
- _____ °
- _____ mV
- _____ Ohms

Response time:

_____ (1 – 60 sec)

Output Limits:

- Span (4 to 20 mA)
- Max (3.5 to 23 mA)
- Specify Low _____ mA, High _____ mA
- NAMUR NE 43 (3.8 to 20.5 mA)

Sensor Error Action:

- Off
- Specify _____ mA
- NAMUR NE 43 upscale (23 mA)
- NAMUR NE 43 downscale (3.5 mA)

Model Selection Guide (34-44-16-07)

Model Selection Guides are subject to change and are inserted into the specifications as guidance only.

Honeywell

STT 3000 Temperature Transmitter Series STT170

Model Selection Guide
34-44-16-07 Issue 35

Honeywell Proprietary

Section 13
Page: STT-19
Effective Date: December 01,2022



Instructions

- Choose Availability column based on Key Number.
- A dot (•) denotes unrestricted availability.
- Select the desired Key Number based on the desired communications protocol.
- Select options and approvals from Tables.

Key Number I II III IV V VI, options

STT17_ - _ - _ - _ - _ - _ - _ - _

List Price equals the sum of all prices for all selections made.

Description	Selection	Availability		
4-20mA Output, RTD input	STT171	↓		
4-20mA Output, universal input	STT173		↓	
HART Protocol, 4-20mA output	STT17H			↓
Configuration tool for STT171, 173 and 17H	STT17C			↓

Table I - Safety Approvals

Approval Body	Approval Type	Location or Classification	00	BS	BN
None	No approval body certifications included		•	•	•
FM, CSA, ATEX	Intrinsically Safe	Class I, Div. 1, Groups A,B,C,D, T4			
		Class I, Zone 0/1; AEx ia IIC, T4			
	Non-Incendive	Class I, Div. 2, Groups A,B,C,D, T4			
		Class I, Div. 2, Groups A,B,C,D, T4			
	* Intrinsically Safe Zone 0/1	Ex II 1 GD, EEx ia IIC, T4..T6			
		Ex II 2 (1) GD, T4..T6			
	Non-Incendive Zone 2	Class I, Div. 2, Groups A,B,C,D, T4			•
		Ex II 3 G, EEx nA [L] T4..T6			

When installed in Field Mount Enclosure Table IV, E __, or T __

Approval	Approval Type	Location or Classification	1G	2G	3S
FM Approval	Intrinsically Safe	Class I, Div. 1, Groups A,B,C,D, T4			
		Class I, Zone 0/1; AEx ia IIC, T4			
CSA	Non-Incendive	Class I, Div. 2, Groups A,B,C,D, T4			
		Class I, Zone 0/1; Ex ia IIC, T4			
ATEX	* Intrinsically Safe Zone 0/1	Ex II 1 GD, EEx ia IIC, T4..T6			
		Ex II 2 (1) GD, T4..T6			

* Ex II GD or II 2 (1) GD allows for installation in potentially explosive atmospheres caused by the presence of combustible dusts only when mounted in a metal enclosure of form B according to DIN 43729 (Head-Mount enclosure) that provides a degree of protection of at least IP 6X in accordance with EN 60529, that is suitable for the application and is correctly installed.

TABLE II - No Option

No Option	0	•	•	•	•
-----------	---	---	---	---	---

TABLE III - Configuration & Certificates

Configuration	None - Factory Default Configuration Supplied	0 __	•	•	•
	Custom Transmitter Configuration with Printed Report **	T __	•	•	•
Calibration	Custom Transmitter Calibration with Printed Report **	C __	•	•	•
Optional Certificates	No Option	_ 0 _	•	•	•
	No Certificate of Conformance/Origin	__ 0	•	•	•
	Certificate of Conformance/Origin	__ R	•	•	•

			Availability				
			STT17_	1	3	H	C
			Selection	↓	↓	↓	↓
TABLE IV - Transmitter Housing and Integral Meters (Reference EN01-6032 for details)							
Housing	No Housing Supplied		0__	•	•	•	•
	Field Housing	Aluminum with Beige Epoxy Coating	E__	d	d	d	
		316 Stainless Steel	T__	d	d	d	
Cable/ Conduit Entry	Not Applicable - No Housing Supplied		_0_	•	•	•	•
	1/2" NPT Cable/ Conduit Entry		_N_	•	•	•	
	M20 x 1.5 Cable/ Conduit Entry		_M_	•	•	•	
Integral Meter	No Integral Meter Supplied		--0	•	•	•	•

TABLE V - Optional Equipment

Mounting	No mounting bracket		0__	•	•	•	•
	Carbon steel pipe mounting bracket for 2" pipe		M__	e	e	e	
	Stainless Steel mounting bracket for 2" pipe		S__	e	e	e	
	Spring loading mounting set		L__	f	f	f	
	DIN rail mounting clip (top hat or G rail)		D__	f	f	f	
M20 adaptors	No adaptors required		_0_	•	•	•	•
	1 adaptor for M20 x 1.5 wiring entry		_1_	•	•	•	
	2 adaptors for M20 x 1.5 wiring entry		_2_	•	•	•	
3/4"NPT adaptors	1 adaptor for 3/4"NPT wiring entry		_3_	•	•	•	
Lightning Protection	No lightning protection supplied		--0	•	•	•	•
	Externally Mountable to Field Mount Housing		--L	•	•	•	
	Internal lightning protection		--S	•	•	•	

TABLE VI - Additional Features

No Selection		00	•	•	•	•
Optional Extended Warranty	Additional Warranty - 1 year	W1	•	•	•	
Customer Tagging	316 SS Wired-on Customer I.D. Tag (4 lines, 28 chars. per line, customer specified information)	TG	•	•	•	b
	316 SS Wired-on Customer I.D. Tag (blank)	TB	•	•	•	
Operator's Manual	STT171 Version; English, French, German Language	M1	•			
	STT173 Version; English, French, German Language	M3		•		
	STT17H Version; English, French, German Language	MH			•	

RESTRICTIONS

Restriction Letters	Available Only With		Not Available With	
	Table	Selection	Table	Selection
b	VI	Select only one option from this group		
d	IV	_N_		
e	IV	E __, or T __		
f	IV	0 __		

ACCESSORIES

	Part Number
DIN rail clip	50017850-001 • • •

** If Custom Configuration option "T" or the Custom Calibration option "C" is ordered, the configuration or calibration information required must be entered as a note on the order. Any of the following elements can be included, based on the selected model number:

(STT171, STT173, STT17H) Tag Number, CJC, Sensor Type, Sensor Wiring, Temperature Units, URV/LRV, Output Range, Output Limits, Sensor Error Action, Response Time.

Sales and Service

For application assistance, current specifications, pricing, or name of the nearest Authorized Distributor, contact one of the offices below.

ASIA PACIFIC

Honeywell Process Solutions,
(TAC) hfs-tac-support@honeywell.com

Australia

Honeywell Limited
Phone: +(61) 7-3846 1255
FAX: +(61) 7-3840 6481
Toll Free 1300-36-39-36
Toll Free Fax:
1300-36-04-70

China – PRC - Shanghai

Honeywell China Inc.
Phone: (86-21) 5257-4568
Fax: (86-21) 6237-2826

Singapore

Honeywell Pte Ltd.
Phone: +(65) 6580 3278
Fax: +(65) 6445-3033

South Korea

Honeywell Korea Co Ltd
Phone: +(822) 799 6114
Fax: +(822) 792 9015

EMEA

Honeywell Process Solutions,
Phone: + 80012026455 or
+44 (0)1344 656000

Email: (Sales)

FP-Sales-Apps@Honeywell.com

or

(TAC)

hfs-tac-support@honeywell.com

AMERICA'S

Honeywell Process Solutions,
Phone: (TAC) 1-800-423-9883 or
215/641-3610
(Sales) 1-800-343-0228

Email: (Sales)

FP-Sales-Apps@Honeywell.com

or

(TAC)

hfs-tac-support@honeywell.com

For more information

To learn more about Temperature Transmitters, visit www.process.honeywell.com
Or contact your Honeywell Account Manager

Process Solutions

Honeywell
1250 W Sam Houston Pkwy S
Houston, TX 77042

Honeywell Control Systems Ltd
Honeywell House, Skimped Hill Lane
Bracknell, England, RG12 1EB

Shanghai City Centre, 100 Jungi Road
Shanghai, China 20061

www.process.honeywell.com

Honeywell

34-TT-03-07

May 2023

©2023 Honeywell International Inc.