

NS Series

The HMI you can rely on



» Proven Reliability

» Best Match

» Machine Management

Machine Control at your fingertips

Expanding markets in emerging countries, short product cycles, and diversifying customer needs are just some of the factors that create drastic changes for the production industry.

To win in severe global market competition, you have to continue to grasp industry changes quickly, understand user needs accurately, and provide diverse forms of added value.

Omron will help you handle ever-changing customer needs with the three keywords of the NS Series.

Let your machines evolve

Best match

Omron has provided even greater compatibility with Omron PLCs and components to provide an advanced design process that lets you achieve appealing machines.

Machine management

The NS Series transforms machine HMIs from simple operation panels and turns them into machine management tools.

Proven reliability

The NS-series HMIs have a proven track record that will take your machines to a higher level of reliability.



NS Series

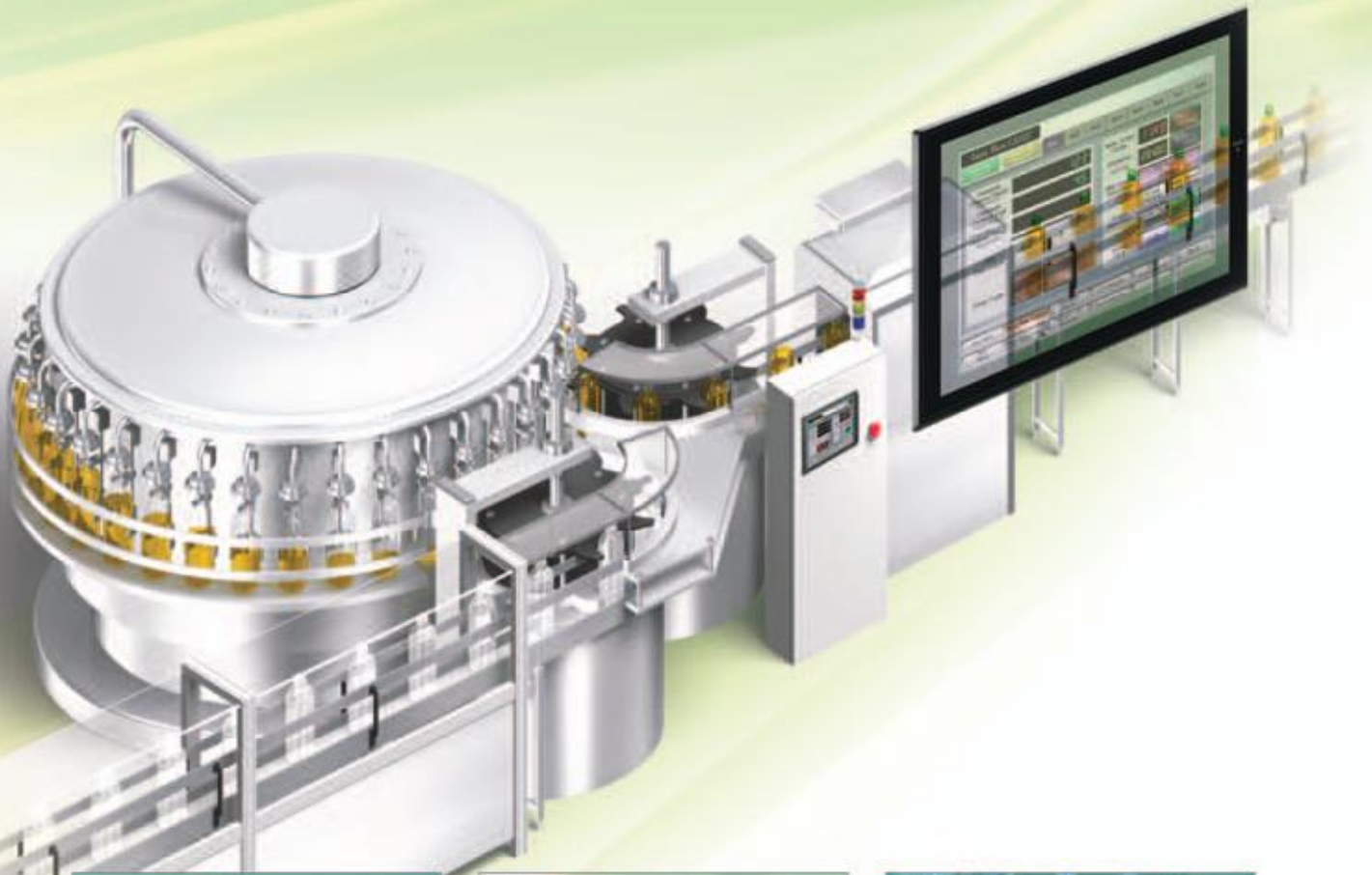

The best match possible

The amount of work and cost of connecting to Omron PLCs and components have been greatly reduced. The results is an incredible range of features that is possible only when unifying to one manufacturer. Connecting to the NJ-series Machine Automation Controller allows the machine designer to quickly achieve the features required by the user through support for improved troubleshooting and structured programming with structures and other new data types.

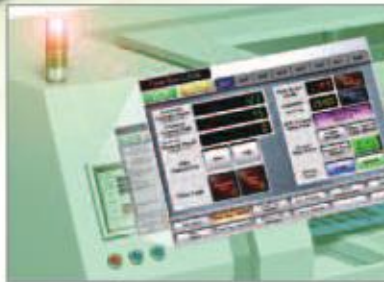

Machine management tool

The machine designer can easily implement PLC troubleshooting, machine troubleshooting, settings for servo drives, temperature controllers, and other control components, status monitoring of connected devices, and uploading/downloading of parameters.









Proven reliability

In the ten years since initial marketing, Omron has globally supplied numerous HMI solutions with the highly reliable NS Series at over 200 sales and service centers around the world.

NS Series Line-up





Standard Models

15 inches	Colour TFT	12.1 inches	Colour TFT LED		
	NS15-TX		NS12-TS		
	32,768 colours		32,768 colours		
	XGA 1024 x 768 pixels		SVGA 800 x 600 pixels		
	Screen memory size: 60 MB		Screen memory size: 60 MB		
	USB Slave		Controller Link		
	Ethernet		Video (RGB input only)		
	USB Master		RGB output		
	RS-232C x 2		Ladder Monitor		
RS-422A/485	Memory Card	RS-232C x 2	Memory Card		
10.4 inches	Colour TFT LED	8.4 inches	Colour TFT LED		
	NS10-TV		NS8-TV		
	32,768 colours		32,768 colours		
	VGA 640 x 480 pixels		VGA 640 x 480 pixels		
	Screen memory size: 60 MB		Screen memory size: 60 MB		
	USB Slave		Controller Link		
	Ethernet		Video		
	USB Master		Ladder Monitor		
	RS-232C x 2		Memory Card	RS-232C x 2	Memory Card
5.7 inches	Colour High-luminance TFT LED	5.7 inches	Colour TFT LED	5.7 inches	Monochrome STN
	NS5-TQ		NS5-SQ		NS5 MQ
	32,768 colours		32,768 colours		16 monochrome gradations
	QVGA 320 x 240 pixels		QVGA 320 x 240 pixels		QVGA 320 x 240 pixels
	Screen memory size: 60 MB		Screen memory size: 60 MB		Screen memory size: 60 MB
	USB Slave		USB Slave		USB Slave
	Ethernet		Ethernet		Ethernet
	RS-232C x 2		RS-232C x 2		RS-232C x 2
	Memory Card		Memory Card		Memory Card

NSH Series

Hand-held Models - A hand-held version of the NS5 is now available to perform operations at the production site.

5.7inches	Colour TFT LED	5.7 inches	Colour TFT LED	Hand-held HMI Cable	
	NSH5-SQR		NSH5-SQG		
	32,768 colours		32,768 colours		
	QVGA 320 x 240 pixels		QVGA 320 x 240 pixels		
	USB Slave		USB Slave		
	RS-232C/422A		RS-232C/422A		
Memory Card	Memory Card	RS-232C	RS-422A		
Equipped with a red switch for an emergency stop input.		Equipped with a gray switch for a stop input.			
Emergency stop (3 inputs)		Emergency stop (3 inputs)			

NSJ Series		Integrated Controller Models -		HMI is unified with the Controller into one package to greatly help standardize equipment and reduce size.		
12.1inches 	Colour TFT LED	10.4 inches 	Colour TFT LED			
	NSJ12-TS01_-G5D		NSJ10-TV01_-G5D			
	32,768 colours		32,768 colours			
	SVGA 800 x 600 pixels		VGA 640 x 480 pixels			
	Screen memory size: 60 MB		Screen memory size: 60 MB			
	USB Slave		Controller Link	USB Slave	Controller Link	
	Ethernet		Ladder Monitor	Ethernet	Ladder Monitor	
	USB Master		Memory Card	USB Master	Memory Card	
	RS-232C x 3		DeviceNet	RS-232C x 3	DeviceNet	
	(Controller Section)		(Controller Section)			
I/O points: 1,280	Program capacity: 60K steps	I/O points: 1,280	Program capacity: 60K steps			
Data Memory: 128K words	Data Memory: 128K words					
8.4 inches 	Colour TFT LED	5.7 inches 	Colour TFT LED			
	NSJ8-TV01_-G5D		NSJ5-TQ11_-G5D			
	32,768 colours		32,768 colours			
	VGA 640 x 480 pixels		QVGA 320 x 240 pixels			
	Screen memory size: 60 MB		Screen memory size: 60 MB			
	USB Slave		Controller Link	USB Slave	Controller Link	
	Ethernet		Ladder Monitor	Ethernet	Memory Card	
	USB Master		Memory Card	RS-232C x 3	DeviceNet	
	RS-232C x 3		DeviceNet			
	(Controller Section)		(Controller Section)			
I/O points: 1,280	Program capacity: 60K steps	I/O points: 1,280	Program capacity: 60K steps			
Data Memory: 128K words	Data Memory: 128K words					

Software



CX-Designer

The software for project creation on the NS series, the CX-Designer Screen Design Software is so easy-to-use that anyone can master it. CX-Designer is included in CX-One and Sysmac Studio.



NS-Runtime

This software enables PLC communications to a personal computer by HMI created screens using CX-Designer.

The NS-series HMIs provide the highest possible compatibility with the road-proven CS/CJ-series the highest new NJ-series Controllers to achieve even greater added value in user machines.

The NJ-series Machine Automation Controllers

You can create a flexible, high-speed, high-precision system based on the NJ-series Machine Automation Controllers. Use tags to access any memory areas, or troubleshoot machines and systems by using the NS-series HMIs to make the most of the strengths of the NJ-series Controllers and to manage machines.



EtherNet/IP

NJ



EtherCAT



The CS/CJ-series PLCs for the reliability of a proven track record

Features are provided to easily connect to CS/CJ-series PLCs to take advantage of their proven track record. Many features that do not require screen creation or programming support everything from design through maintenance to take advantage of the compatibility of Omron PLCs and HMI and to serve as the face of your machines.

CS/CJ



Design

From conceptual designs through commissioning, operation, and maintenance, the NS Series supports every user need.

Reduced work



Troubleshooter

PAGE
10-11

NJ Troubleshooter

PLC Troubleshooter

Machine Troubleshooter

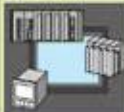

Best Match

PAGE
12-16

Smart Active Parts (SAP)

With EtherNet/IP

Direct Connection to temperature controllers



Multi-language Support

PAGE
16



Data logger & Recipe handling

PAGE
17



Screen Data Security Functions

PAGE
18



Device Data Transfer

PAGE
18



Multifunction Objects

PAGE
19



Versatile Graphs

PAGE
20



Good looking Screens and Objects

PAGE
21



CX-Designer Screen Design Software

PAGE
22-25

Start-up/operations

Attractive, convenient features for easier operation



Level:01
Level:02
Level:03
Level:04
Level:05



260,000-colour Video Display PAGE 26



Analog RGB Output PAGE 26



FTP Function and Web Interface PAGE 27



User Security Functions PAGE 27

Features for reliability and complete maintenance



Single Port Multi Access PAGE 28



PLC Data Trace PAGE 29



Operating log PAGE 29



Ladder Monitor PAGE 30-31



Ordering and technical information PAGE 35-39

Troubleshooter

A Troubleshooter is provided for the connected Omron controller or PLC. This greatly reduces work requirements.

NJ Troubleshooter

Controller errors

Standard feature for NJ-series controllers

Errors are automatically detected and displayed on-screen along with corrective actions for the CPU unit, function modules, EtherCAT slaves, and CJ-series units that are connected in the NJ-series controller. Whenever an error might occur, you can recover normal operation quickly to reduce downtime without using user manuals, or support software on a computer.



User-defined errors

No Work Is Required to Create Alarm Screens.

Frames for alarm screens are provided as standard features in the NS-series HMIs. There is no need to create these screens separately. Management of the meanings of alarms is unified on the Controller, so you do not have to register, add, or correct addresses on the NS-series HMIs.

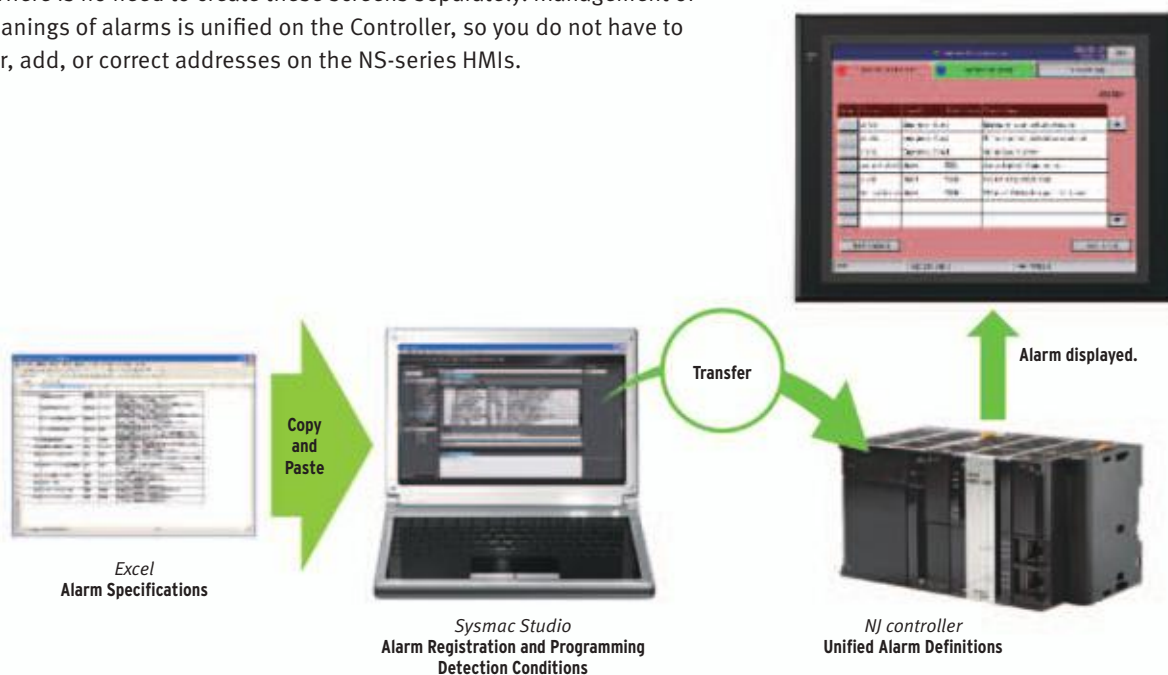

CS/CJ-series PLC Troubleshooter

Constantly monitors PLC errors

Automatically detects PLC errors and displays the error details and recovery procedure on the screen. Even if a problem occurs, it can be resolved quickly without referring to the manuals.

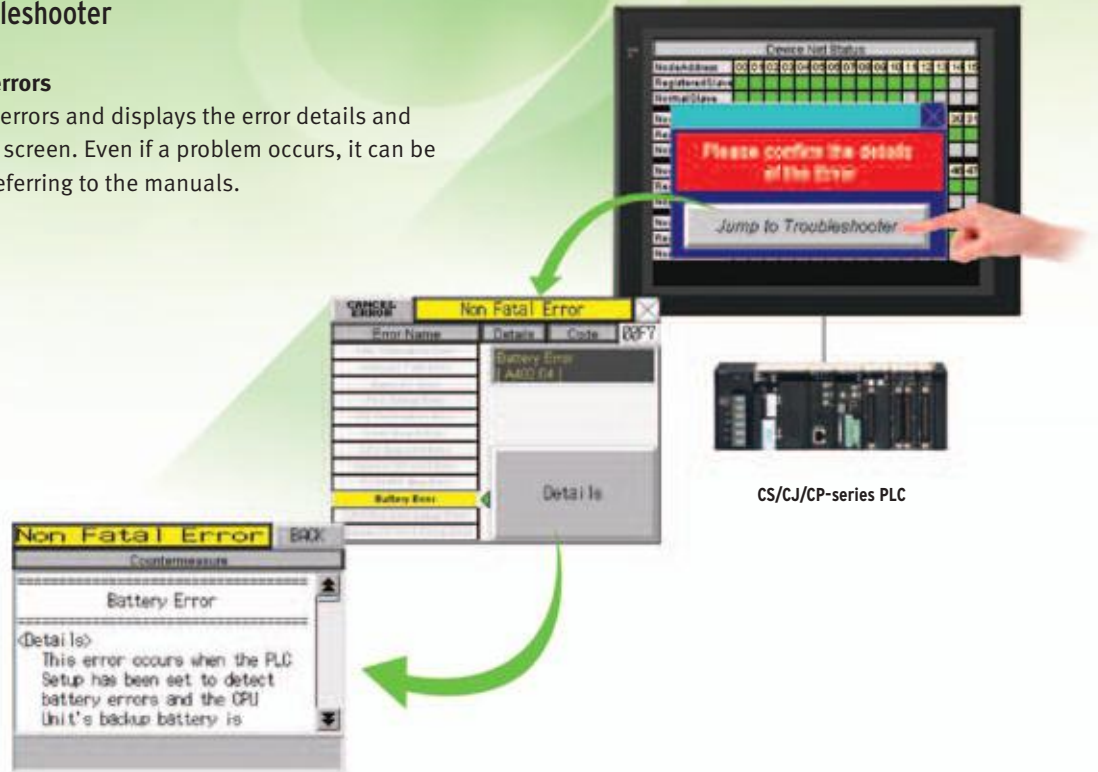

Machine Troubleshooter

Easier design of machine error screens

Individual error screens that were previously made for each error can now be integrated into one. It is possible to switch only the error details (text and screen) without ladder programming in conjunction with the alarm bit.

Specific example

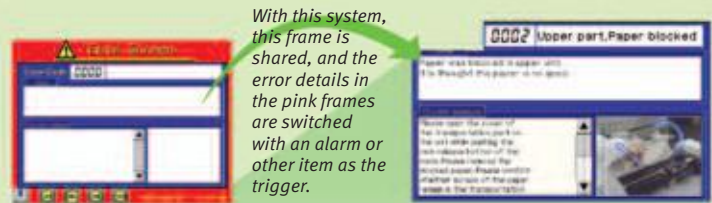

in conjunction with an alarm bit

Alarm bit 10.01 ON
(no paper)



Text selection

Image selection

Alarm bit 10.02 ON
(printing error)



Text selection

Image selection

Best Match

NS Series is the most suitable HMI for the system that comprises Omron components. The advantage is the compatibility (reducing programming and screen data creation work), which will reduce the amount of designing work.

No Screen Designing / No Programming

NS



PLC CPU Unit monitoring screen

Device monitor



PLC Data Trace

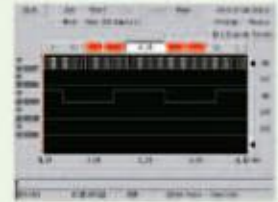

Temperature controllers



PLC

CPU Bus units an Special I/O units

- SAP Library
- Troubleshooting



Remote I/O



Inverter



Vision Sensor

- 260,000-colour video input



Temperature Controllers



Servomotor Servo Driver



Smart Active Parts (SAP Library)

Significantly reduces the effort required to create ladder programming and screens. More than 3,000 library parts (Smart Active Parts) are available, which can directly access Omron PLCs and components. The objects can just be pasted from the Smart Active Parts (SAP Library) to the screen; it is completely unnecessary to create screens and ladder programming.

The temperature controller's setting and monitor screens are completed in no time.

SAP Library, Temperature Controller Parts

CX-Designer Screen Design Software

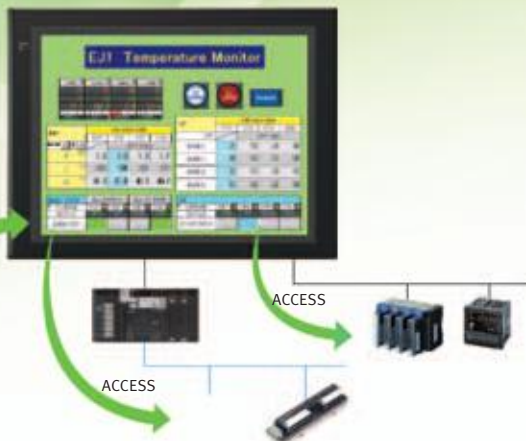

Example screens using support tool objects (Tool Function SAP Library)

Support tool objects can be incorporated to check for errors and make settings, even without a computer.

Plenty of support tool objects (the Tool Function SAP Library) are available, which can easily be incorporated into support tool functions in the NS-series HMI. Just paste the support tool objects in the screen to check for errors and make settings, even without a computer.

PLC CPU unit monitoring screen



NCF unit setting screen

DeviceNet monitoring screen

Computer support tools

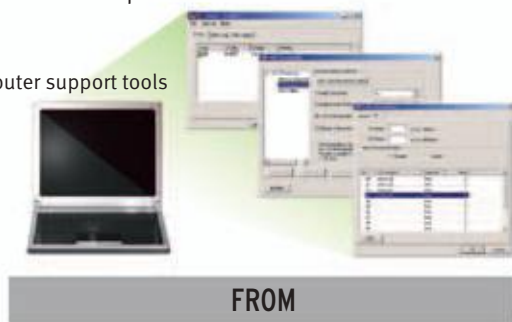

FROM

TO

CPU Bus unit and special I/O unit troubleshooting can also be performed with the SAP Library.

A Troubleshooter SAP Library is available to troubleshoot each Unit in the PLC. When an error occurs in a Unit, the Troubleshooter SAP Library provides an easy-to-understand explanation of the cause of the error as well as the countermeasures.

Troubleshooter SAP for a Position Control unit

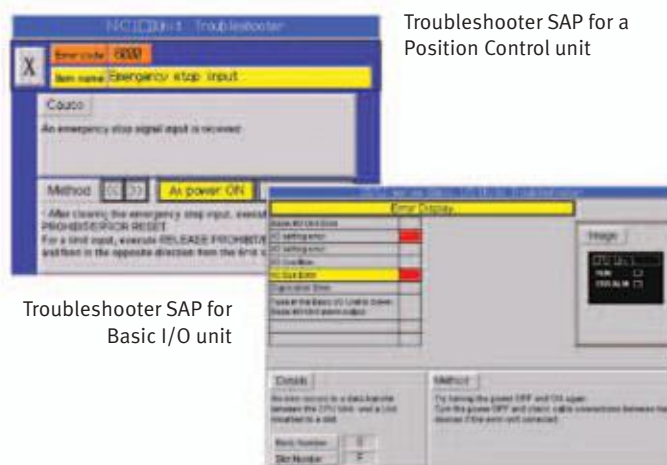

Troubleshooter SAP for Basic I/O unit

EtherNet/IP

Support for data structures This special feature is made possible by combining an Omron CJ2 PLC with an NS-series HMI. The data structures that you define on the Programming Tool can be used on the CX-Designer simply by dragging and dropping them.

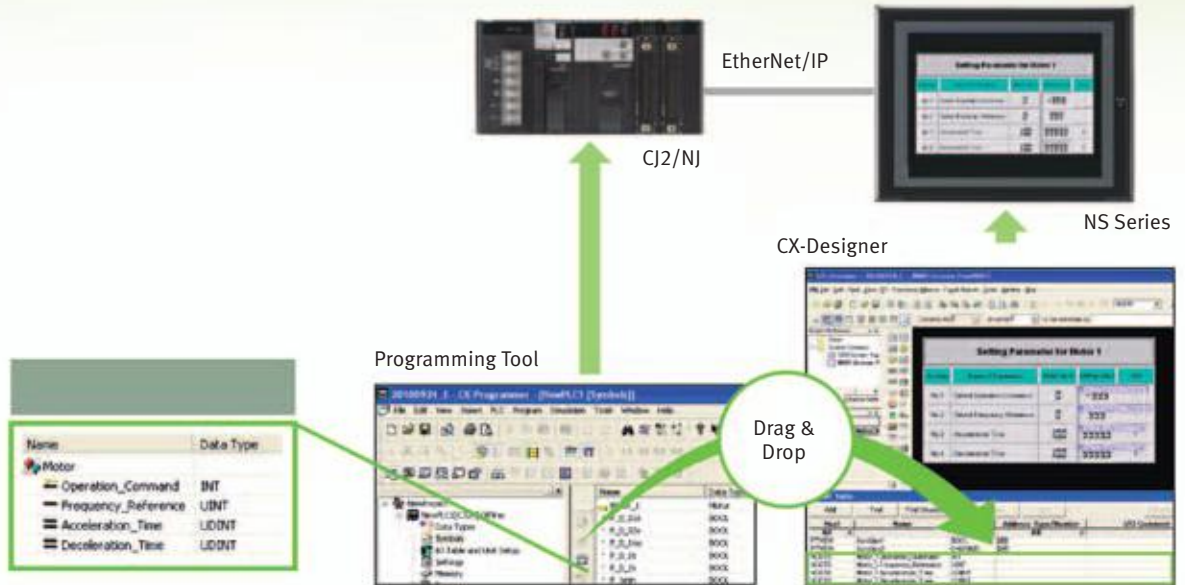

Tag access

A tag is a name given to an address. Tags are managed in the CJ2 CPU Unit, where they are defined as network symbols. The common user-defined tag names are used from programmable terminals and host applications to access memory in a CJ2 CPU Unit without knowing the physical address.

1. Tag names are managed at the PLC with the CX-Programmer.

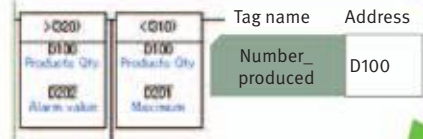

2. For example, create screens with tag names without typing the physical address.



3. All devices will access with Common "Tag"

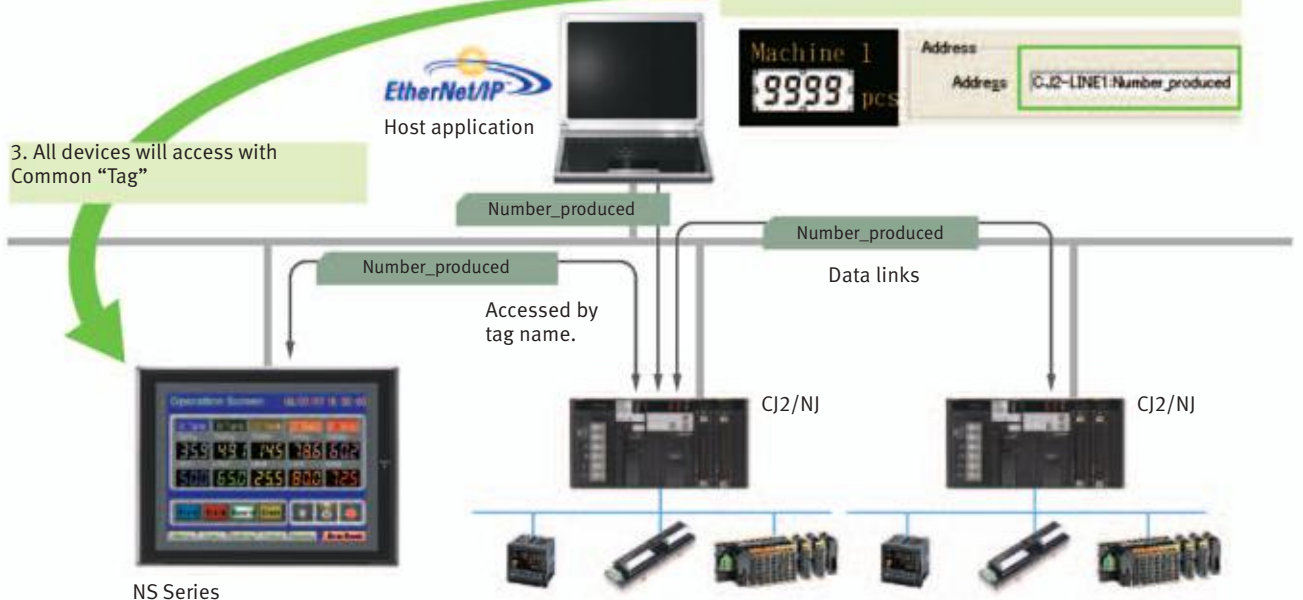

NS Series

Simultaneous and parallel engineering

The host applications can be designed using the tag names of the PLC and HMI. Parallel development will shorten the design time.

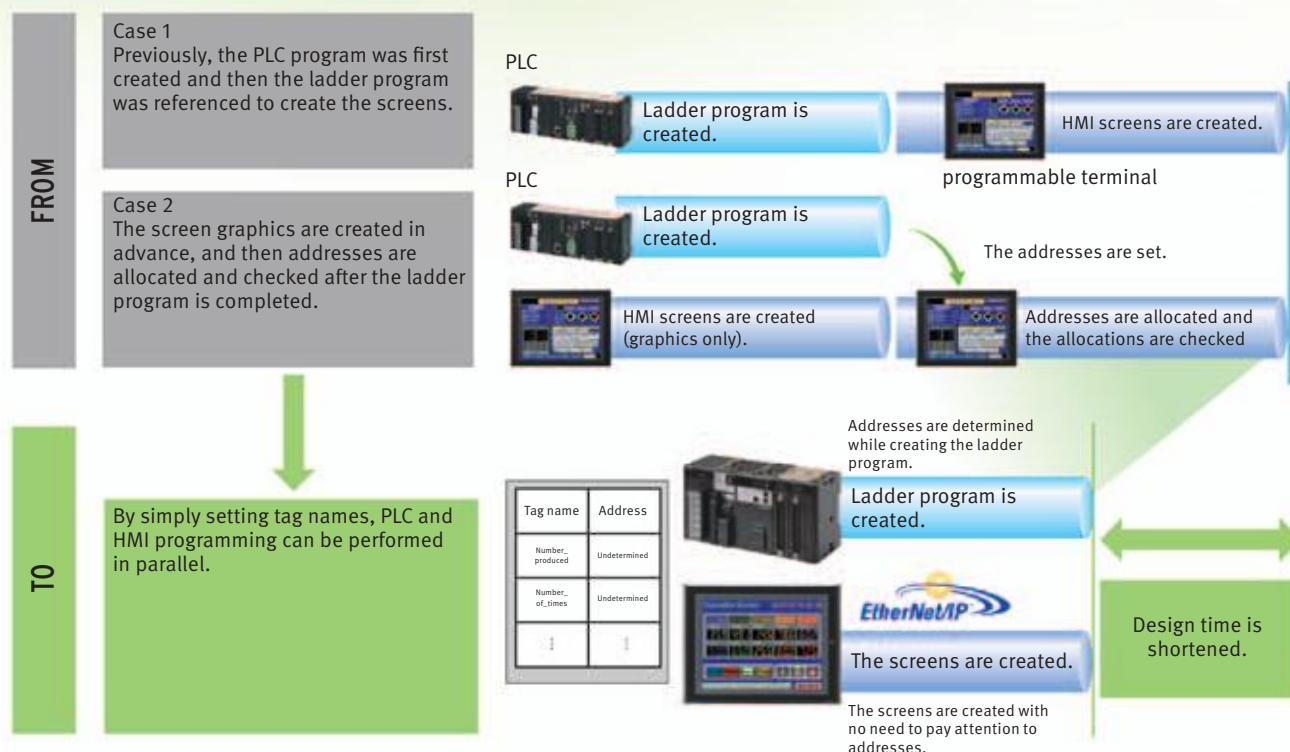

Minimize side effect of address changes

It is possible to access memory with tags, so the HMI and host application are not affected even if the address of data in the PLC is changed.

Specific example

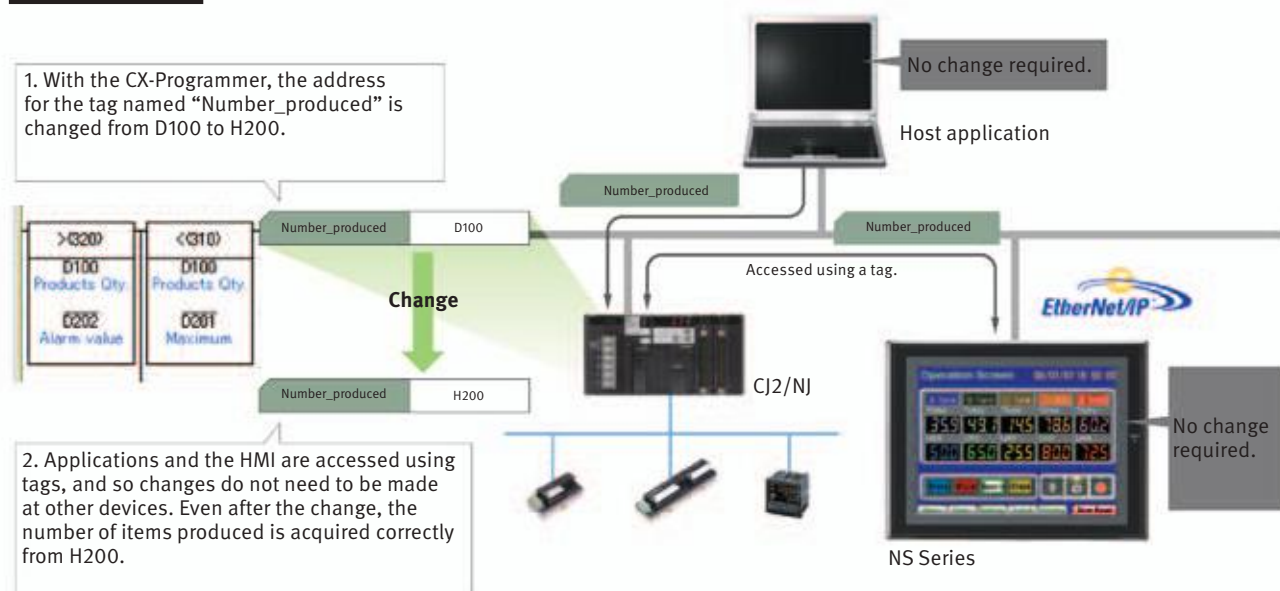

Direct Connection to temperature controllers

Connect Omron temperature controllers directly to the NS-series HMI.

Omron Temperature Controllers can be connected directly to the NS-series HMI's RS-422A. Data does not pass through the PLC, so ladder programming is not required. Also, there are plenty of objects in the SAP Library for temperature controllers, and temperature controller screens can be created easily just by pasting objects from the SAP library to the screens.



Multi-language Support

Support 42 languages and switch the language of the labels among up to 16 languages.

Unicode is supported and 42 Asian and European languages can be combined in screens. Also, it is possible to switch between up to 16 labels using the label switching function, so it is possible to support up to 16 languages in a single screen just by specifying the language to be displayed in each label.

Multi-language conversion is easy.

The screen data in the source language is exported to a CSV file and sent to a translation agency by e-mail for translation. Later, the translated CSV file is just imported to easily provide multi-language support.

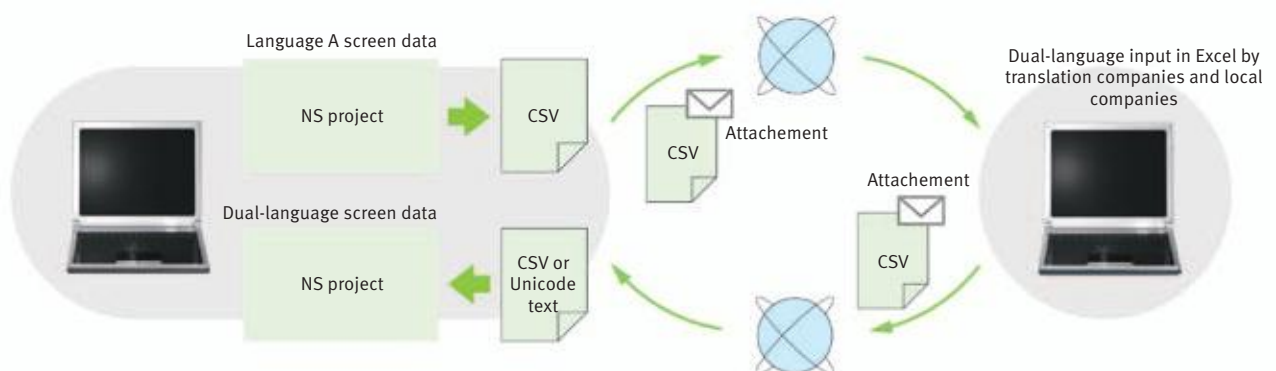

Data logger

Log large amounts of data using a personal computer. Data can be logged through background processing, with up to 160,000 points stored in one file. The logged data is stored in CSV format, and data can be displayed on data log graphs.

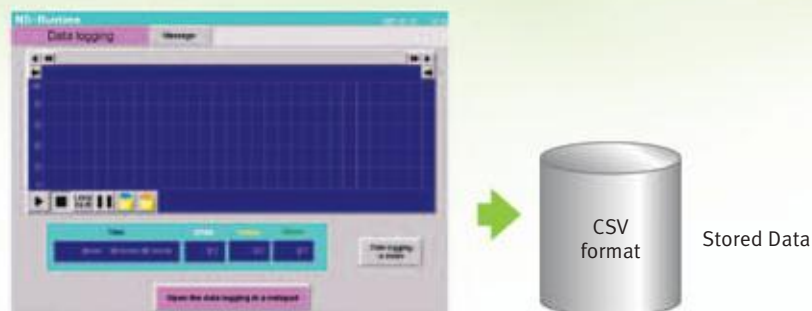

Example: 160,000 Points

Data can be logged for approximately 7.4 days, assuming data is logged every two seconds for 12 hours a day. By using automatic file saving, data logging can be continued even longer than 7.4 days.

Recipe handling

Checking machine data or switching processes from a host computer is easy. Parameter groups in the PLC can be transferred together to a computer, and the transferred data can be checked and edited in CSV format, e.g., using Excel. The edited data can then be transferred together back to the PLC.

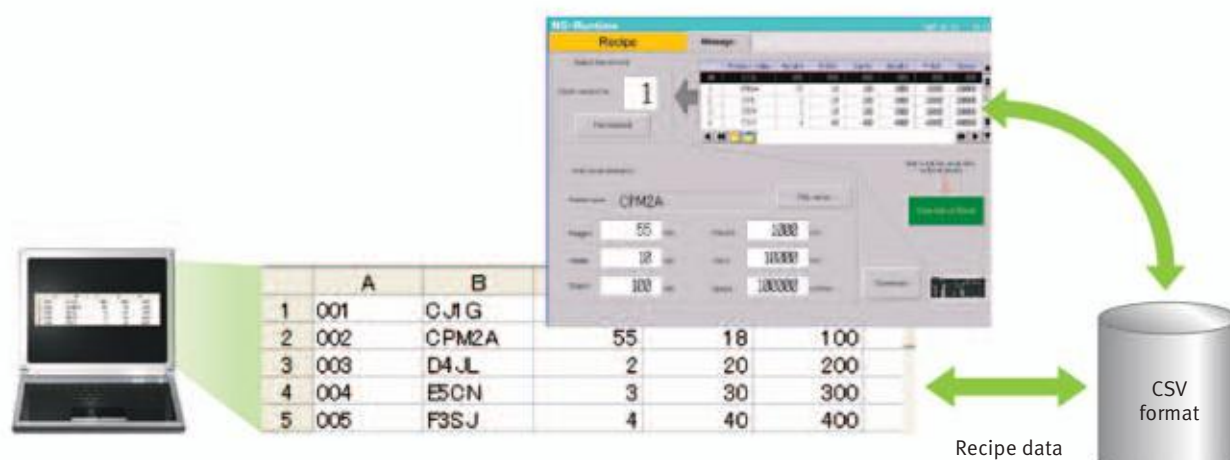

Screen data security functions

Protect important screen data with a password.

If password protection is set in the data transfer security settings when the screen data is designed, a password must be entered to download or upload the screen data, so important screen data can be protected.

Security password



A password between 4 and 64 characters long can be set. The download/upload will start if the user inputs the password that was set when the screen was designed. (Password input will be disabled if the wrong password is input 3 times in a row.)



If a password has been set, the password is required to transfer screen data (download or upload) with the Memory Card.

Device data transfer

Easy Data Exchange between the PLC and Components

For example, temperature controller alarm values can be transferred to the DM Area of the PLC's CPU unit. No communications programming or macros are required.

Multi-vendor support

Devices from multiple vendors are supported. Data can be easily exchanged with PLCs from other companies and Modbus devices.

Multi-vendor support

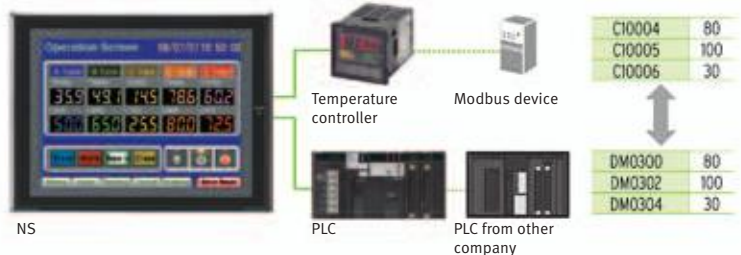

Easy settings

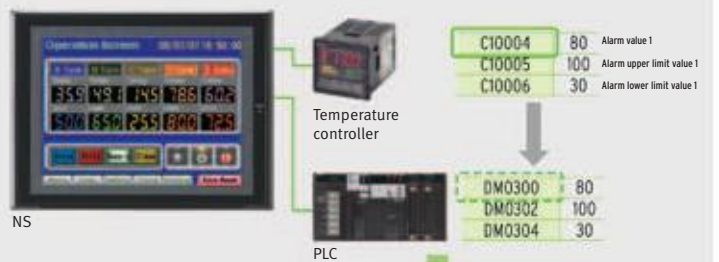

CX-Designer select device data transfer setting from the HMI menu.

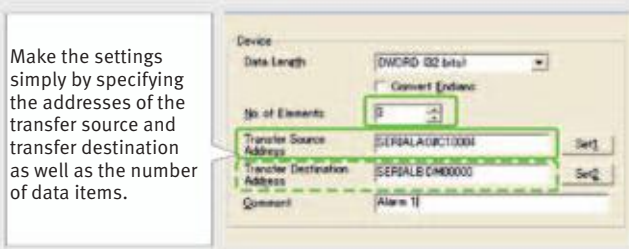

Make the settings simply by specifying the addresses of the transfer source and transfer destination as well as the number of data items.

Device

Data Length: DMC0 02 bits

Convert Endless:

No. of Elements: 3

Transfer Source Address: SERPALAGC10004 [Set]

Transfer Destination Address: SERPALC DM00000 [Set]

Comment: Alarm 1

Multi function

Execute up to 32 functions with one multifunction object.

Multifunction objects combine the functions of multiple objects into one object. Multiple functions can be executed by pressing one button without using troublesome macros. Setup is easy. For example, a setting can be made on-screen using the support software to turn ON a bit to start a machine, set a value and then change the screen.

Multifunction execution with one object

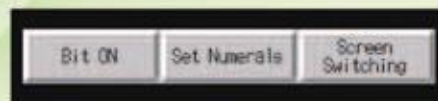

Integration



Execute multiple functions with one button.

Easy On-screen Setup with Support Software!

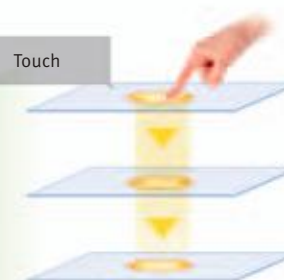

Example: The bit turns ON.
 The word is set.
 The screen changes.

Multifunction objects support four useful functions

Switches that do not immediately operate when touched can be easily made without ladder programming.

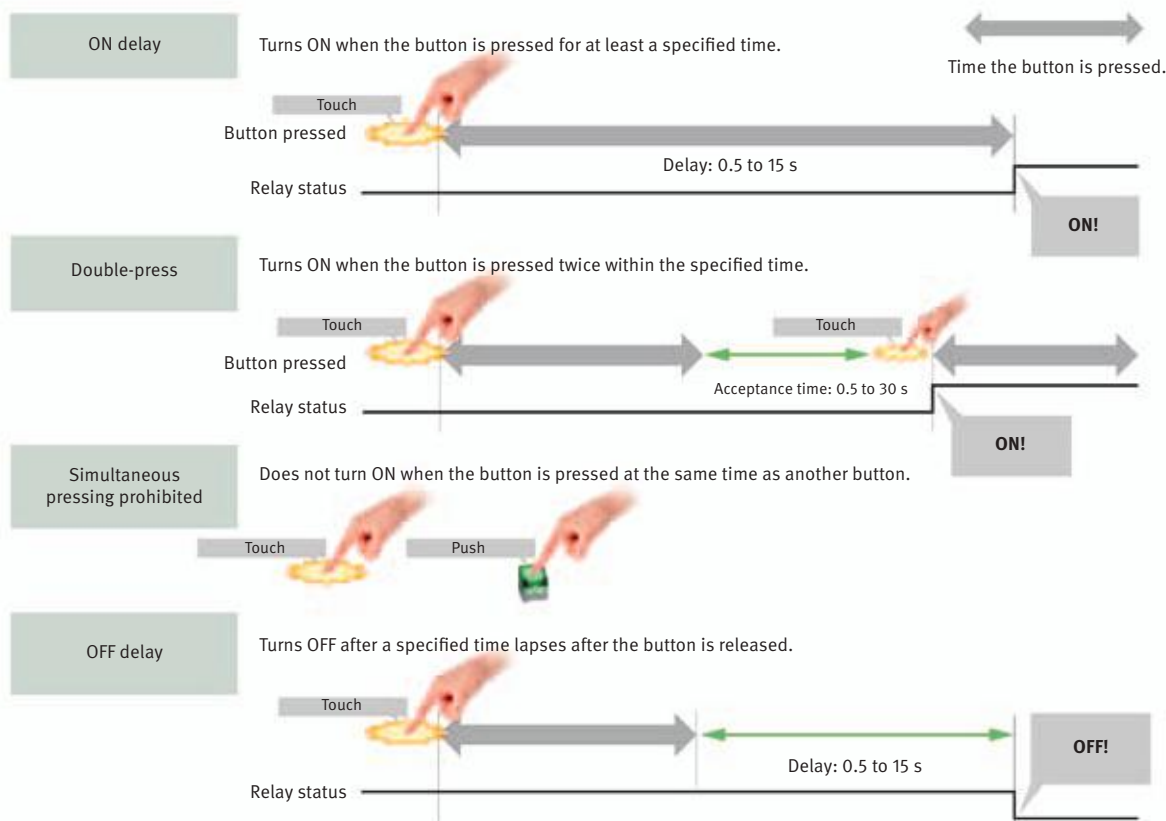

Versatile Graphs

Data Log Graph (Trend Graph)

Up to 128 data can be collected in the cycle of 500ms. Logging data is stored as a CSV file in the memory card inserted in the NS-series HMI.

Logging data is stored as a CSV file in the Memory Card mounted in the NS-series HMI. The data stored in the memory card can be read or deleted from the screen.

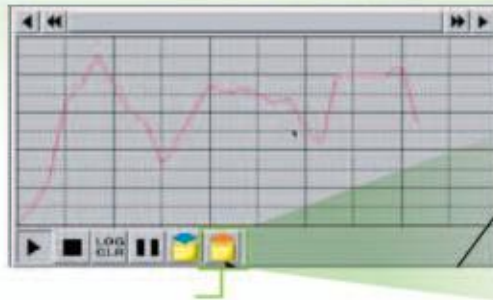

The log data files in the memory card appear as shown below when the read file button is pressed.

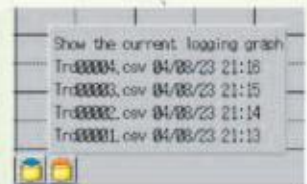

Suffixes are automatically added to file names set in the CX-Designer.

A log can be saved automatically, without any programming, just by selecting the Save the data periodically option in the data log setting window.



LOG001.CSV	04/06/04	10:00
LOG002.CSV	04/06/05	10:00
LOG003.CSV	04/06/06	10:00
LOG004.CSV	04/06/07	10:00
LOG005.CSV	04/06/08	10:00
LOG006.CSV	04/06/09	10:00
LOG007.CSV	04/06/10	10:00

Logging data for each day (43,200 points) is saved in the memory card in CSV format.

It is possible to make a one-week log by automatically saving the data seven times.

Line graph function

The data logged by the PLC can be displayed in overlapping graphs, so a device's operation can be compared for evaluation and analysis. In addition, up to 1,000 words of consecutive data can be displayed as a line graph, data can be displayed together and any region can be magnified.

(1) Graphs can be superimposed.

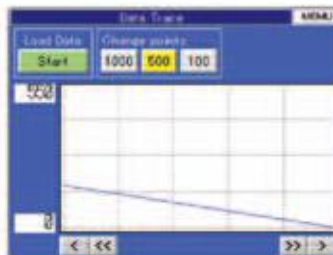

(2) The display can be magnified.

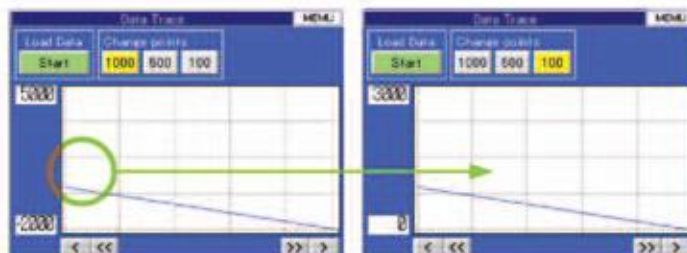

Continuous line function

Any position from the host (PLC) can be plotted as a graph. A graph can be plotted in any position by specifying the X and Y coordinates of the vertices. Also, the graph can be moved on the screen by specifying the movements from the PLC.

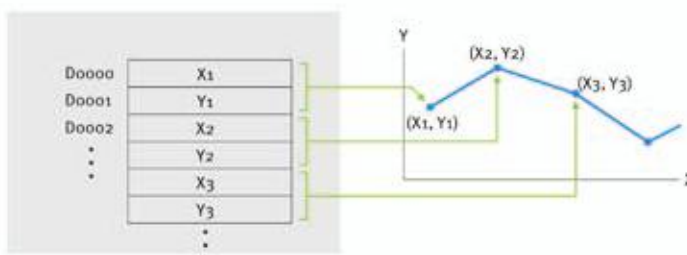

Good looking screens and objects

“Cool” screen templates

Professionally designed screen templates are provided. There are seven different types of attractive screen templates for different themes. Simply select the best template from the library.



“Cool” objects

Backgrounds, buttons, labels, message boxes, and other objects are also provided for various themes.



Screen Designer for NS Series, CX-Designer

User-friendly screen creation

Without screen creation and ladder programming, the CX-Designer Screen Design Software is so easy-to-use that anyone can master it. Quickly create the required screen by dragging and dropping objects. Omron's unified development environment lets you drastically reduce the work required to create screens.

All addresses and comments can be managed using a single Symbol Table.

Improved Icons and Help Shows a list of addresses, names, and comments used in project screen data. Addresses, names, and I/O comments for the CX-Programmer can also be imported.

Host	Name	Type	Address	Type/Number	I/O Comment	Type
ALL	STOP	BOOL	ALL	STOP SWITCH		Network Variable
ALL	RUN	BOOL	ALL	RUN SWITCH		Network Variable
ALL	AUTO	BOOL	ALL	AUTO SWITCH		Network Variable
ALL	STOP	BOOL	0001	STOP SWITCH		None
ALL	RUN	BOOL	0002	RUN SWITCH		None
ALL	AUTO	BOOL	0003	AUTO SWITCH		None
ALL	STOP	BOOL	0004	STOP SWITCH		None
ALL	RUN	BOOL	0005	RUN SWITCH		None
ALL	AUTO	BOOL	0006	AUTO SWITCH		None
ALL	STOP	BOOL	0007	STOP SWITCH		None
ALL	RUN	BOOL	0008	RUN SWITCH		None
ALL	AUTO	BOOL	0009	AUTO SWITCH		None

Improved Icons and Help

Search Result: 4 entries found

Page	ID	Host	Name	Address	I/O Comment	Label	Object Comment	Detailed Information
0010	NUM0014	SERIALA	AutoGen4	DM01001				Numerical Display & Input: Address
0010	NUM0013	SERIALA	AutoGen4	DM01001				Numerical Display & Input: Address
0010	NUM0012	SERIALA	AutoGen4	DM01001				Numerical Display & Input: Address
0010	NUM0011	SERIALA	AutoGen4	DM01001				Numerical Display & Input: Address

The project Workspace enables the user to look through the entire project.

- Screens you want to edit can be opened right away.
- Perform screen management, such as copying or deleting screens, by simply right-clicking.
- Reusing screens from other projects is easy with the CX-Designer.
- Settings for alarms, data logs, communications, and other functions can be easily accessed.

Drastically reduce the number of clicks in the project.

Just click on the object once to display or change properties. Multiple objects can be selected to display and change shared properties all at once.

The Output Window shows search results.

In addition to addresses and I/O comments used in screen data, labels can also be used as search strings and the results can be displayed.

Reading the symbol table

The symbol table created in the CX-Programmer during ladder programming can be read into the CX-Designer by dragging and dropping, so it isn't necessary to manually enter data such as input addresses and I/O comments. Tags (i.e., network symbols) can also be read into the CX-Designer.

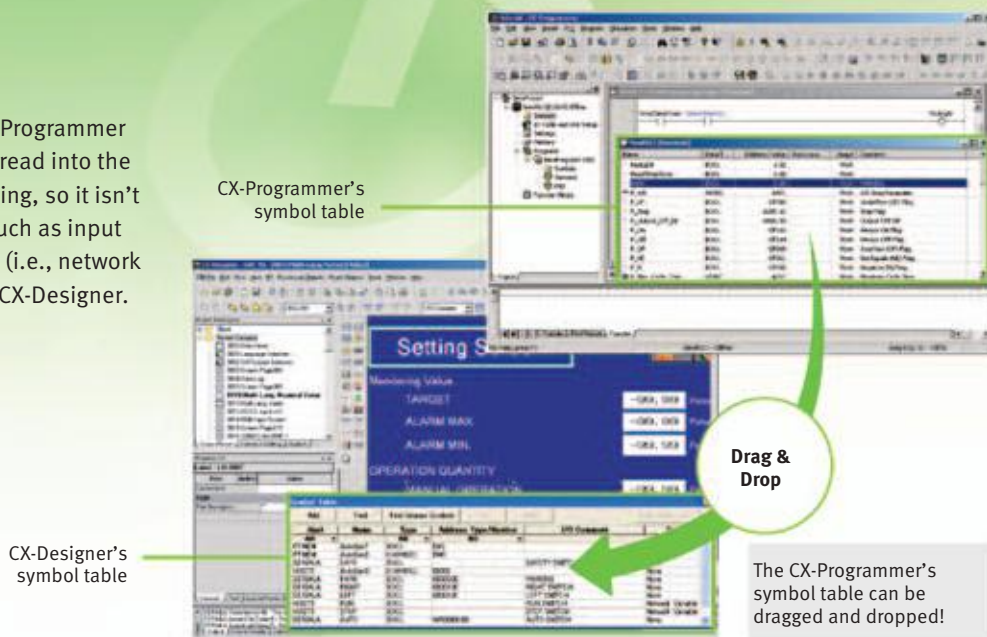

Example of Reading the Symbol Table

The symbol table read from the CX-Programmer can be directly dragged and dropped to the touch switch and lamp.

(1) Create a switch on the screen.

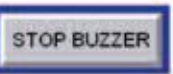

(3) Allocations for buttons and lamps can also be checked on the screen using comments imported from the CX-Programmer.



Example of easy address allocation

(2) Check the comment then drag-and-drop the symbol from the symbol table to the property list.

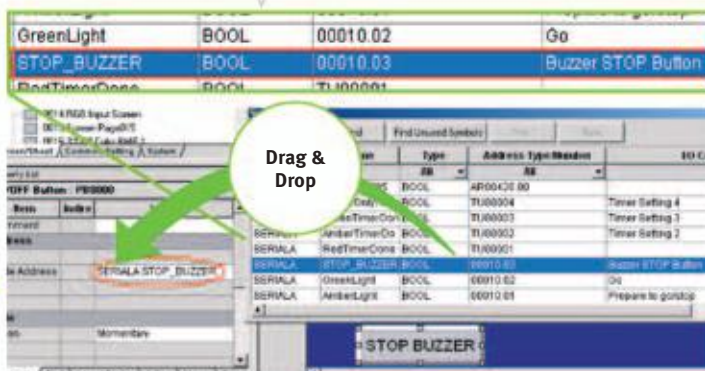

Example of reading I/O comments

If Use I/O comment is selected in advance for the Use symbol text as label, the I/O comments are automatically used as labels when addresses are dragged and dropped from the symbol table. (If Use symbol names is selected, the symbol names are used as the labels.)

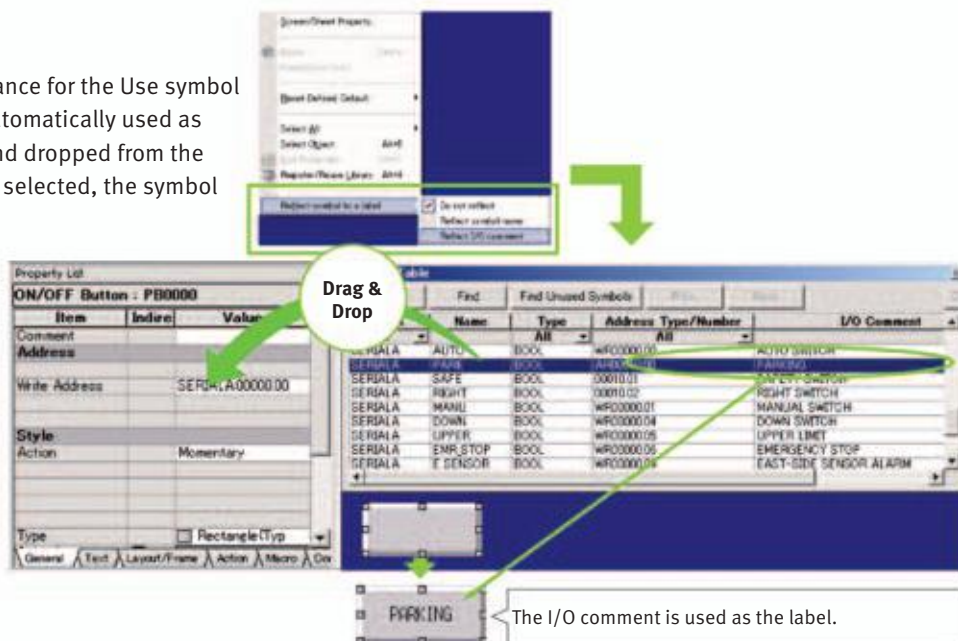

Reading another project's screens and objects

Resources from another project can be easily reused by just selecting the screen or objects that you want to read and dragging and dropping it, so screens can be created intuitively.

Example screen 1

Select the screen that you want to read, drag it to the destination and drop it.

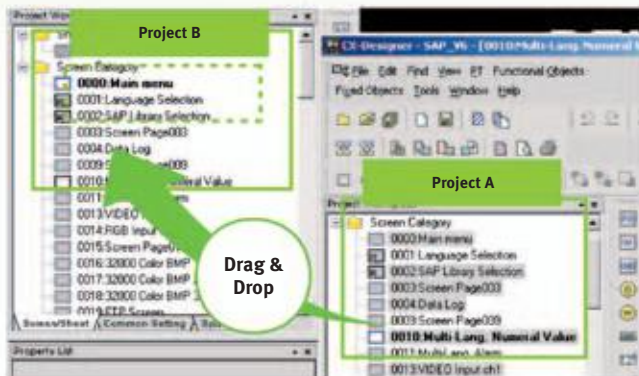

Example screen 2

Select the part that you want to read, drag it to the destination and drop it.

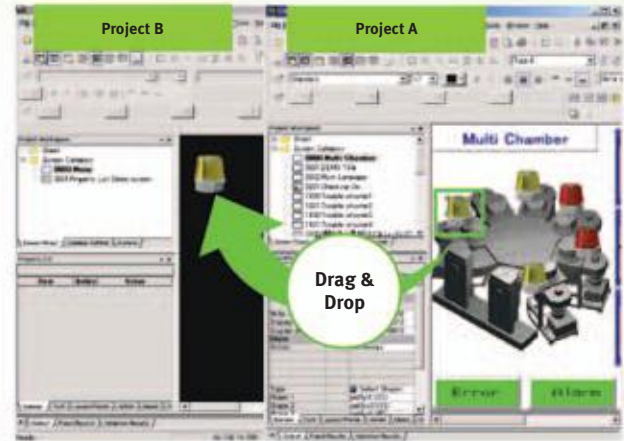

Reading CAD Files

It is possible to import DXF files by dragging and dropping them. The files are read as a diagram, and so less capacity is used than with images. It is also easy to customize the diagram by changing the shape or colour.

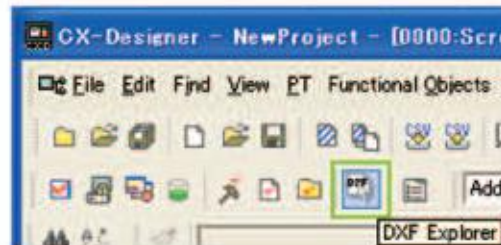

The screen data and ladder program can be checked simultaneously in the computer

The CX-Designer and CX-Programmer interconnects the test functions in the computer through the CX-Simulator. The screens and ladder program checks are performed simultaneously, which significantly increases debugging efficiency. The CX-Programmer also has a new button for integrated simulation. And, work efficiency is further improved with the ability to keep required work screens pinned on front and to zoom in or out as desired.

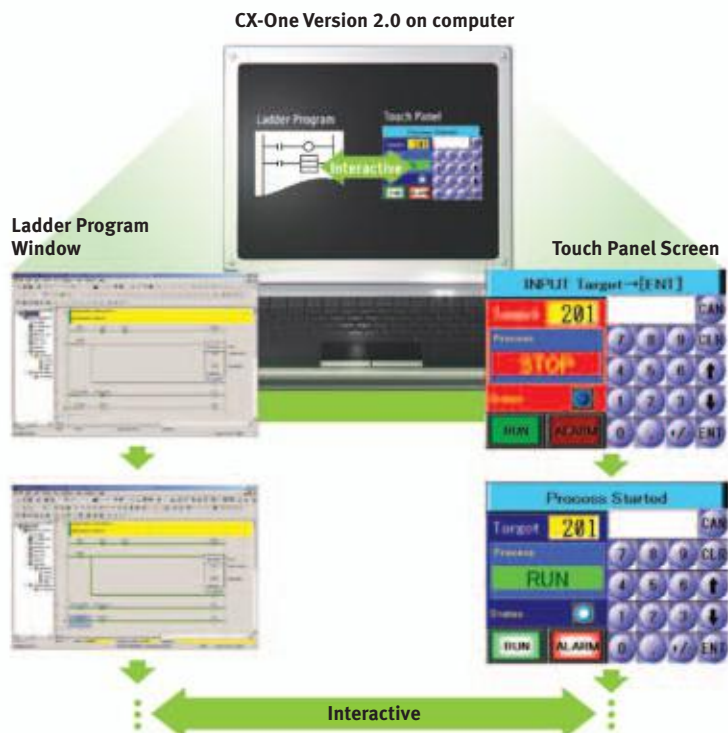

Editing of multiple objects

Addresses and other settings, such as labels and colours, can be set together in a list, making editing operations much more efficient. When the common attributes (such as background colour and text colour) of multiple parts are being changed, the attributes can be changed together using the property list.

Example screen 1 After editing the settings in the list, press the OK Button to make the new settings effective immediately.

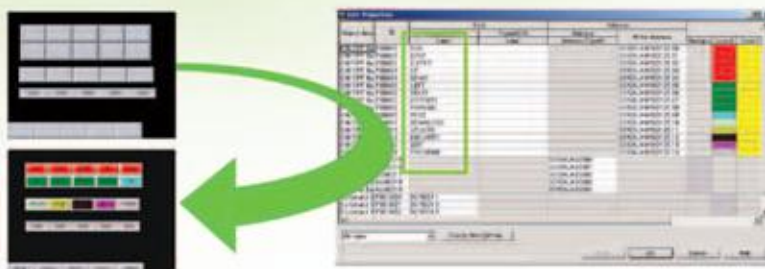

Example screen 2 If the background colour is changed from white to grey in the property list, the background colour is changed for all of the selected objects.

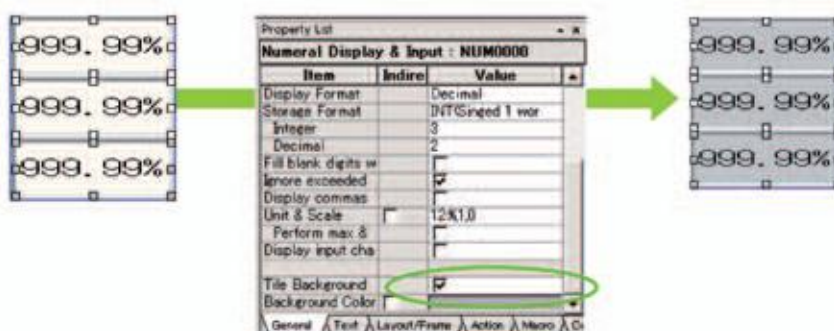

Editing of overlapping objects

The Select Object command is a powerful tool when you want to edit objects hidden by overlapping. A filter function can also be used to aid editing by displaying only the objects to be edited.

Object Selection Window

Right-click and select Select Part to display the objects (all types) on the screen.



Select Object				
All types				
		Range Selection	Release All	
O	Object Comment	ID	X	Y
B		PL0000	96	136
B		PL0001	200	136
B		PL0002	304	136
B		PL0003	408	136
B		PL0004	96	184
B		PL0005	200	184
B		PL0006	304	184
B		PL0007	408	184
B		PL0008	96	232
B		PL0009	200	232
B		PL0010	304	232
B		PL0011	408	232
B		PL0012	96	280
B		PL0013	200	280
B		PL0014	304	280
B		PL0015	408	280
LBL		LBL0016	72	168
LBL		LBL0017	96	80

Filter Function

Use the Select Part command's filter function to select the objects (ON/OFF Button) that you want to edit.



Only the edited object is displayed and it can be edited easily.

260,000-colour Video Display

NS-CA001 Video Input Unit Four video inputs or CCD cameras can be connected and up to four images can be displayed simultaneously if the image size is 320x240 pixels. The NS-CA001 cannot be used with the NS5 or the NS15.

NS-CA002 RGB/Video Input Unit There is an analog RGB input terminal in addition to the two video input terminals. Either of the video signals or the analog RGB signal can be displayed on the NS-series HMI. The NS-CA002 cannot be used with the NS5.

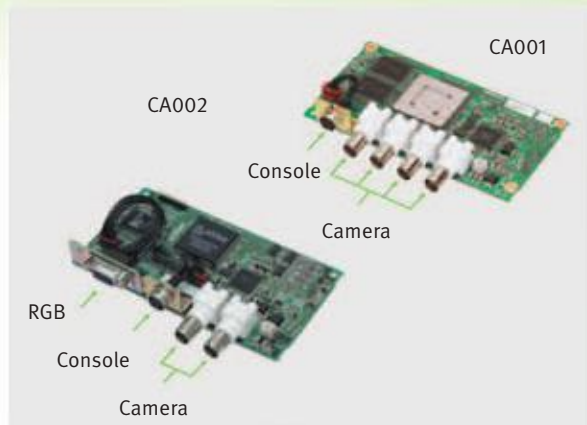

Also compatible with Omron Vision Sensors.



Analog RGB Output

The NS screen viewed on another monitor.

The NS15 screen (XGA) can be displayed on another on-site display that has RGB inputs.



FTP function.

FTP (File Transfer Protocol) allows texts, lists and recipes to be replaced with the put/get command from your computer! You can even replace BMP files.



WEB interface

Monitor and operate the full content of any NS screen on a connected web browser. You can control the full application running on the HMI and even retrieve the log files.



User security functions

Operator access rights and the operating format can be set to one of five password levels.

Each operator can be given one of 5 password levels using the User Security (level authentication) function. A password level can be set for each object, so various objects can be made inoperable or hidden based on the operator's access level.

Operator passwords are managed in 5 levels. Passwords can be up to 16 characters long and the access rights increase as the level number increases.

Level	Role	Access Level
Level 1	Line Operator	Low
Level 2	Group Leader	Level 2
Level 3	Line Manager	Level 3
Level 4	Maintenance	Level 4
Level 5	Administrator	High

The operator cannot manipulate objects with a password level (authentication level) higher than the operator's login level.



Single Port Multi Access (SPMA)

Transfer ladder program data to the PLC via the HMI. Perform online editing via the HMI.

[Computer (Serial/USB) -> NS-series HMI (Ethernet) -> PLC (Ethernet or Controller Link) -> PLC]

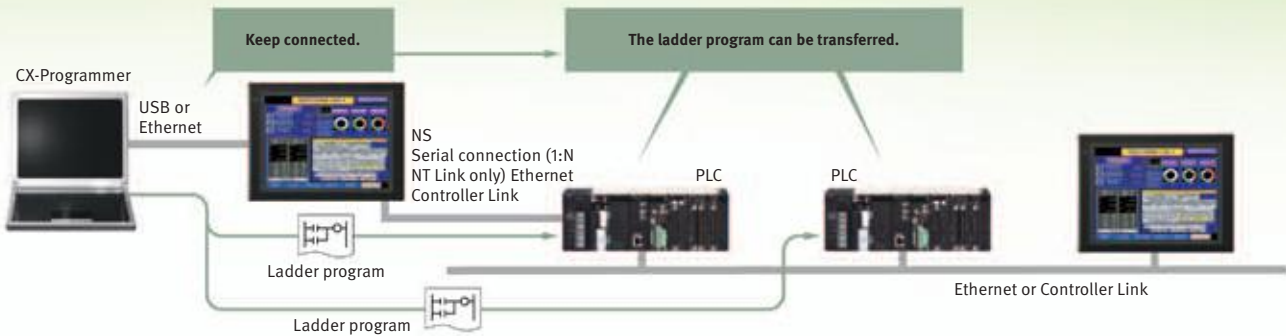

Transfer screen data via the PLC.

[Computer (Serial) -> PLC (Ethernet or Controller Link) -> NS-series HMI]

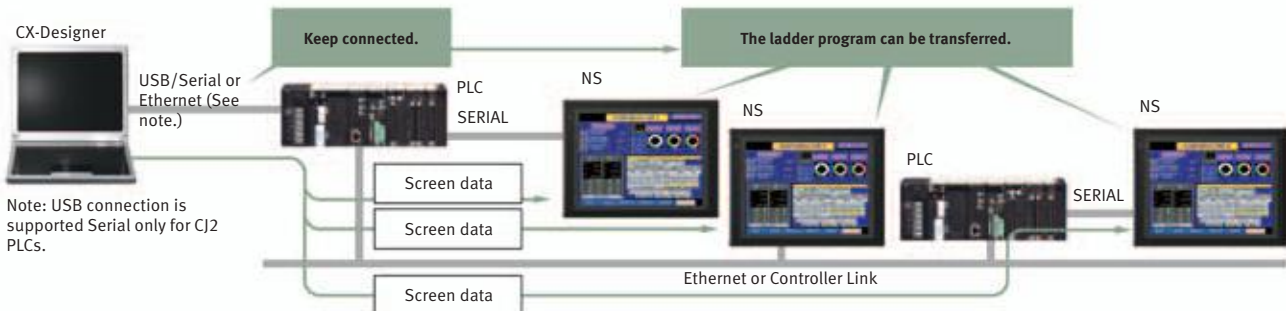

Note: USB connection is supported Serial only for CJ2 PLCs.

Note: SPMA can be used in CS/CJ-series PLCs with lot number 030201 or later.

Note: SPMA via a PLC is not supported when a CP-series PLC is connected. (SPMA via an NS-series HMI is supported with a CP-series PLC.)

Easy automatic connection

A search is automatically made for the PLCs connected to the HMI and the results are displayed using the automatic online connection function in the CX-Programmer. Just select a PLC from the list to connect. This function is also supported for PLCs over network layers.

PLCs registered to the HMI are automatically searched for. Make the connection simply by selecting from the PLC list.



Note 1: SPMA can be used in CS/CJ-series PLCs with lot number 030201 or later.

Note 2: SPMA via a PLC is not supported when a CP-series PLC is connected. (SPMA via an NS-series HMI is supported with a CP-series PLC.)

Note 3: CX-Programmer version 8.2 and higher support automatic online connection via the HMI. NS system version 8.2 or higher is required.

PLC Data Trace

The PLC data trace function can be used without a computer.

The PLC Data Trace function is built into the HMI in addition to the Ladder Monitor and Device Monitor. A bit's status and operation can be viewed in a time chart just by setting the desired PLC bit's address in the HMI. It is also now possible to display word data, save data in CSV files, and save time chart screens in BMP files.

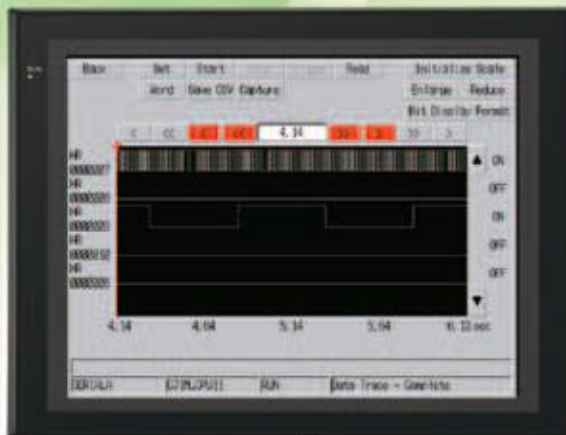

- Note 1: There are differences between this Data Trace function and the CX-Programmer's Data Trace function. Refer to the NS-series Programmable Terminal Programming Manual (Cat. No. V073) for details.
- Note 2: The PLC data trace function cannot be used with the 5.7-inch model.
- Note 3: The PLC data trace function is not supported for connection with a CP1E PLC.



Operating log

What was touched, when and by whom?

Functionality has been improved with the addition of a log to record operators' use of the panels. It is now possible to record and display the time, date, and operation details for buttons (i.e., hardware switches) pressed on the control panel in addition to operations on the touch panel. The operation log can be saved in a CSV file on a memory card mounted in the NS-series HMI.

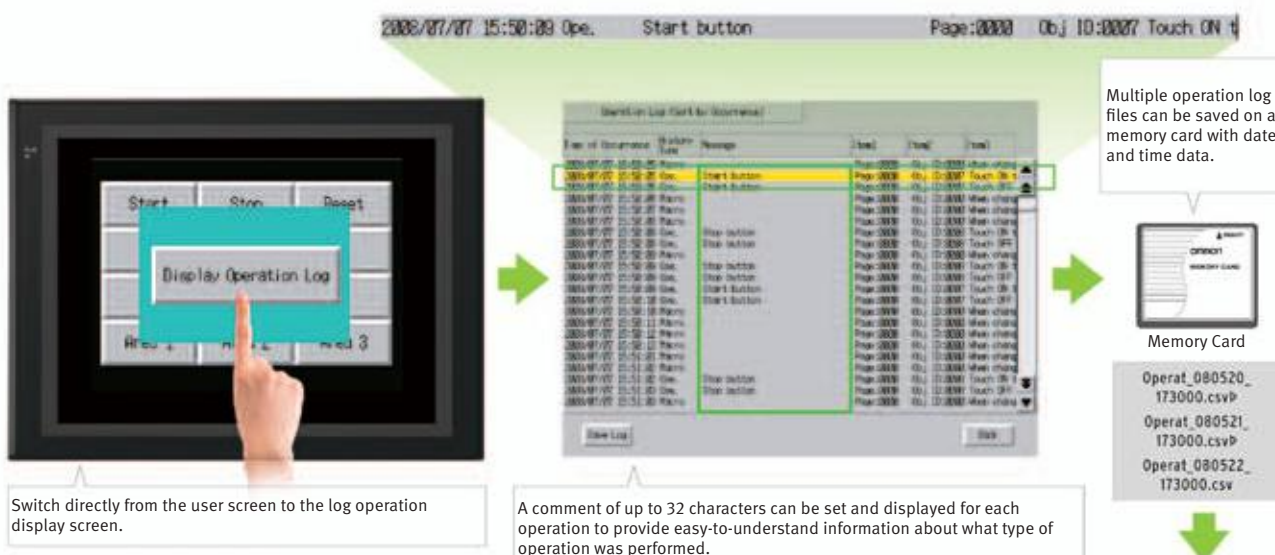

Switch directly from the user screen to the log operation display screen.

A comment of up to 32 characters can be set and displayed for each operation to provide easy-to-understand information about what type of operation was performed.

Multiple operation log files can be saved on a memory card with date and time data.

The files can be opened in Excel.



For example, with a control panel comprised of the NS-series HMI, hardware switches, and an emergency stop button, you can even record and display operation of the emergency stop button.

Line	Time	Message	Page	Event
1	2008/7/7 15:48 M	Start button	PG 03	Start
2	2008/7/7 15:48 M	Stop button	PG 03	Stop
3	2008/7/7 15:48 M	Emergency stop button	PG 03	Emergency stop
4	2008/7/7 15:48 M	Start button	PG 03	Start
5	2008/7/7 15:48 M	Stop button	PG 03	Stop
6	2008/7/7 15:48 M	Emergency stop button	PG 03	Emergency stop
7	2008/7/7 15:48 M	Start button	PG 03	Start
8	2008/7/7 15:48 M	Stop button	PG 03	Stop

Ladder monitor

The ladder program can be monitored without a computer. Ladder programs with I/O comments can be monitored on the HMI's screen and the ladder program can also be edited with the Programming Console function.

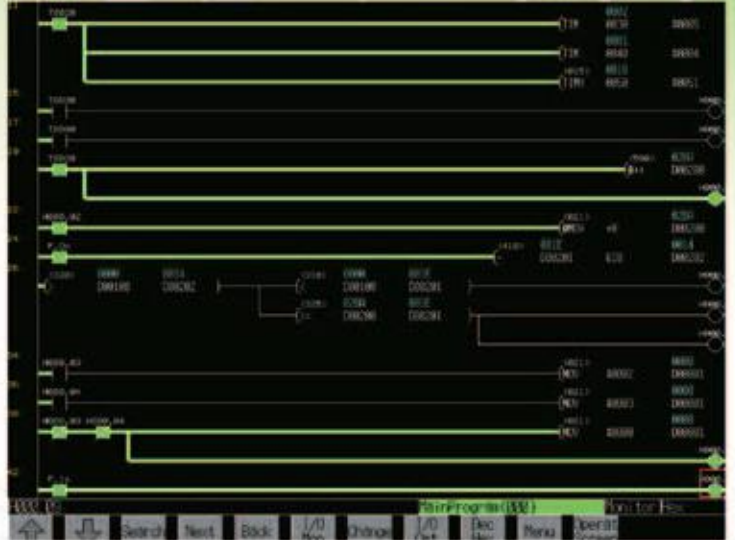

Also meets the requirements of users who need to display devices onsite

Switch Box function

The operator can check the PLC status by displaying just the I/O comments and status.

Device Monitor function

Displays the device's contents, allowing settings to be input and checked and making startup operations more efficient.

Switch Box function



Easy checking the alarm bit and shortens searching time.

When an alarm occurs, touch the message to automatically search for the alarm bit (output bit) for the alarm. This enables you to quickly check the alarm address and investigate why the bit turned ON.



“Find Back”, “Find Next”, useful function supported by the NS-series.

Reduced Time to Investigate Which Output or Input Is Causing the Problem.

Device Monitor function	Operation with NS-series HMI	CX-Programmer
Find the address at specified by the cursor.	Next	“N” Key
Find the output from the input bit or find the input bit from the output at the cursor.	Double-click	“Space” Key
Return to the previous search position.		“B” Key

2. Is this input the cause? What output corresponds to this input?

4. Which of these two inputs is the cause? Let's look at CIO 21.00 first.

6. So is it input CIO 21.01 after all?

Yes, the problem is here!

1. Why is this output not turning ON?

3. Why is this output not turning ON?

5. There's no problem with input CIO 21.00. Let's go back to the previous program section.

Back

Force-setting and force-resetting are possible

Locations that have been force-set are displayed in pink and can be checked at a glance.

1. Select the input bit for which the output will be forced ON.

2. Select the address by touching the panel.

3. Select the Forced Set option and then press the update Button.

4. Forced ON

Minor changes in values of timers or counters can be made without support software.

Check and change I/O While You View the Ladder Diagram on the I/O Monitor

Display and change the present value by specifying the address. It is also possible to force-set/reset bits with the I/O monitor.

Make the selection with the I/O monitor by touching the screen.

Changing the present value of the address selected with the Change Value Button.

Note: The Ladder Monitor function is not supported by the 5.7-inch models.

NS-NSRCL (NS-Runtime)

Achieve machine/line monitoring and data logging on your office computer.

Machine Viewer

Machine viewer in an office environment. There is no need to create complex host applications. Moreover, when an alarm occurs, a PDF file can be displayed as maintenance information. NS Series screens can be reused on the computer and screens can be also newly created independently of touch panels at the production site.

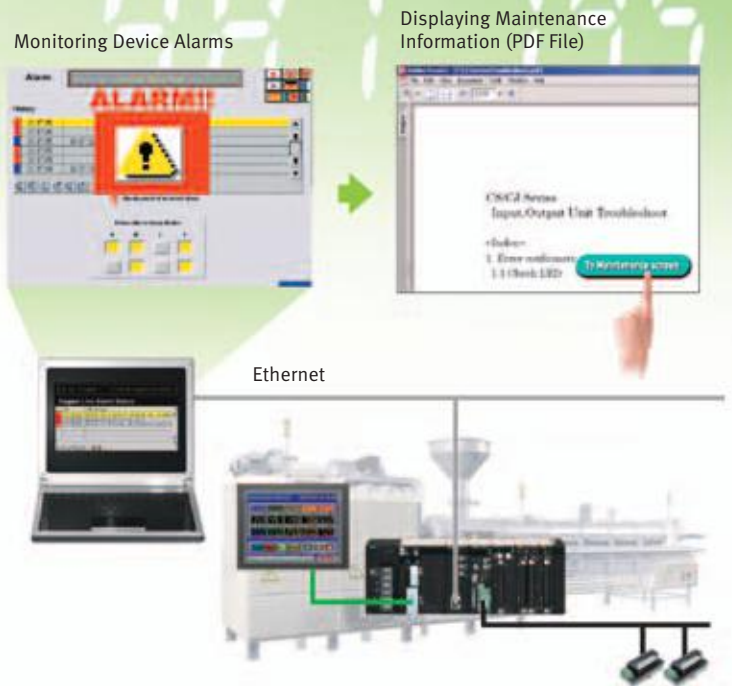

Wide Screen

Computer output can be displayed on another wide-screen monitor. XGA (1,024 x 768 dots) and up to a maximum screen size of 3,840 x 2,400 is supported. Alarms occurring in devices or the line can be monitored.

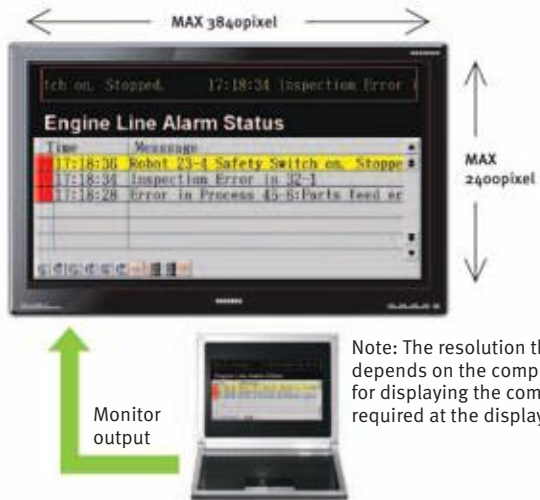

Note: The resolution that can be displayed depends on the computer. An input function for displaying the computer screen is required at the display monitor.

Data logger

Log large amounts of data using a personal computer. Data can be logged through background processing, with up to 160,000 points stored in one file. The logged data is stored in CSV format, and data can be displayed on data log graphs.

Example: 160,000 Points

Data can be logged for approximately 7.4 days, assuming data is logged every two seconds for 12 hours a day. By using automatic file saving, data logging can be continued even longer than 7.4 days.



Recipe handling

Checking machine data or switching processes from a host computer is easy. Parameter groups in the PLC can be transferred together to a computer, and the transferred data can be checked and edited in CSV format, e.g., using Excel. The edited data can then be transferred together back to the PLC.

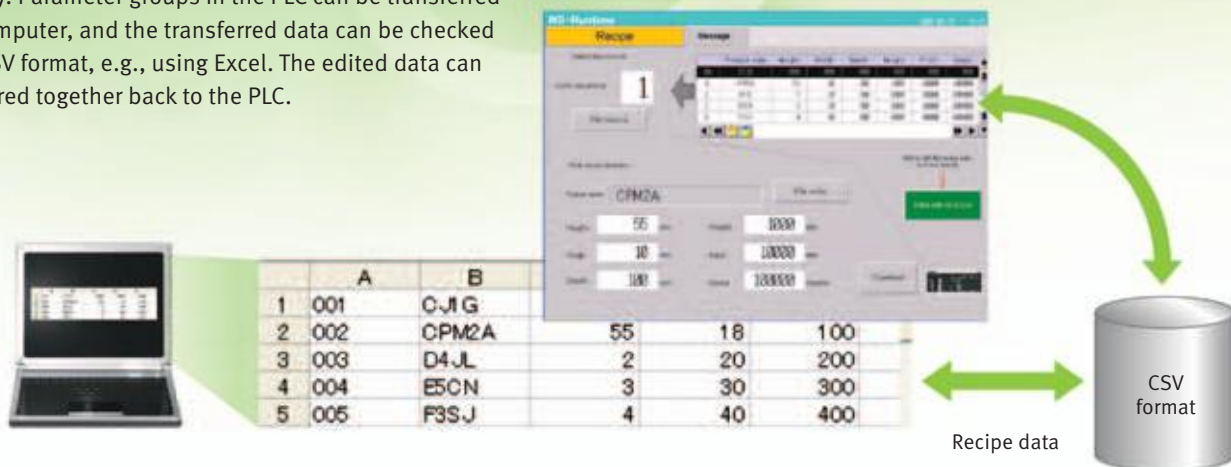

Easy installation

To get started, just install the NS-Runtime in the computer and place the screen data in the applicable folder. NS/NSJ-series screens and NS-Runtime screens can all be managed using one single tool.

Note: The NS-Runtime will operate in a computer environment even if the CX-Designer is not installed. The hardware key (USB dongle) that is supplied with the NS-Runtime is required for operation.

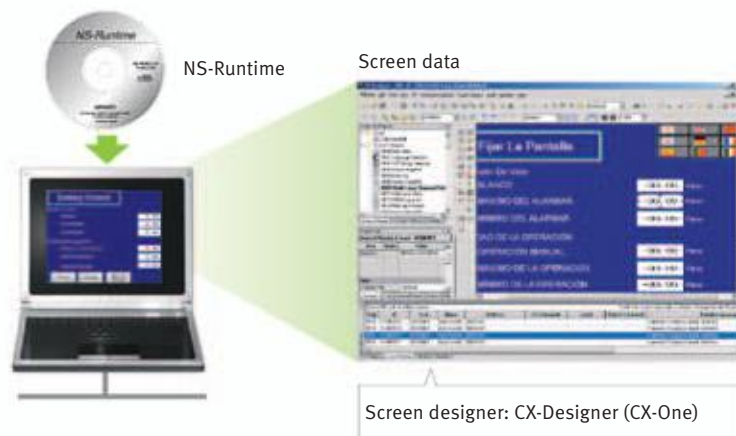

Application startup function

User applications can be started from NS-Runtime. Applications can be started simply by pressing buttons on the screen.

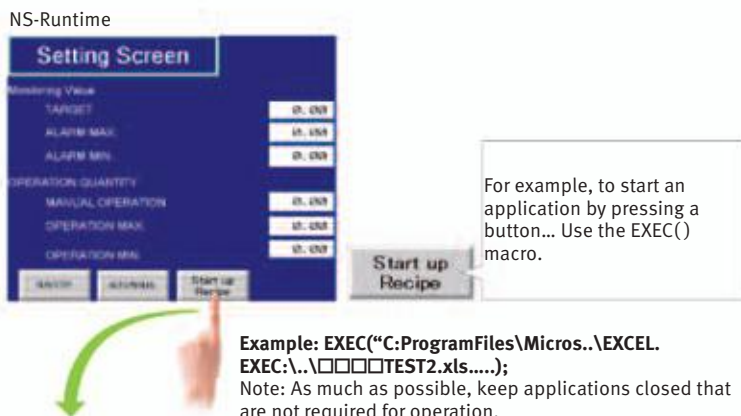

- Note 1: If the screen data is converted from the NS Series, NS-Series HMI system versions must be 8.1 or lower.
- Note 2: Do not use this product for 24-hour operation in an FA environment. Omron shall not be responsible if the computer or application does not operate properly due to noise or other causes. Omron shall not be responsible for any problems that may be caused by any applications other than Omron products.

	A	B	C	D
1	Setting Item	Parameter	Pressure	Oil W
2	Common parameter	1	600	600
3	Production unit	2	700	700
4	Frequency of occurrence of alarm	3	800	800
5		4	900	900
6	Read from PLC		Write to PLC	
7			Print	

HAND-HELD HMI

NSH5 Series

A hand-held version of the NS5 is now available to perform operations at the production site. The NS-series HMI's have a complete set of functions that can be used at the production site, such as the SAP Library, multi-language support, and Programming Console functions.

Function Switches
Use the ten functions switches. F1, F2, F6, F7: Wired outputs F3 to F5, F8 to F10: Communications outputs

Memory Card Interface and USB Slave Connector.

Emergency Stop Switch.
3PST-NC Structure
DPST-NC: Increase safety (wired outputs). SPST-NC: Input to internal NSH5 memory, output to a lamp for emergency stop switch operation, or output via communications, e.g., to a PLC.

Water Resistance to IP65
The water-resistant structure is equivalent to IP65 on all surfaces. The HMI may not be suitable for use in environments with long-term water exposure.

HMI and Cable Sold Separately
Select the Cable according to the application (RS-232C/RS-422A). Connector-loose wires, UL connector, 3 m or 10 m.

3-Position Enable Switch
Increased safety with DPST-NO structure (wired outputs).

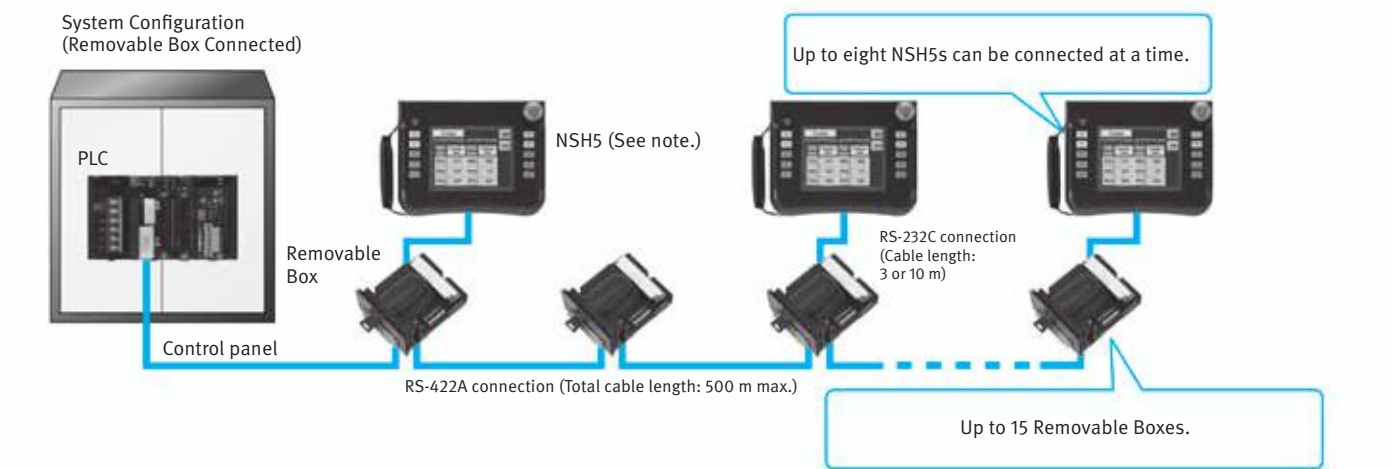

Ordering Information

International Standards

- The standards are available as follows: U: UL, U1: UL (Class I Division 2 Products for Hazardous Locations), C: CSA, UC: cULus, UC1: cULus (Class I Division 2 Products for Hazardous Locations), CU: cUL, N: NK, L: Lloyd, and CE: EC Directives.
- Contact your OMRON representative for further details and applicable conditions for these standards.

Programmable Terminals

Product name	Specifications				Model	Standards
	Effective display area	Number of dots	Ethernet	Case color		
NS5-V2 *1	5.7-inch STN monochrome	320 × 240 dots	No	Ivory	NS5-MQ10-V2	UC1, CE, N, L, UL Type4
				Black	NS5-MQ10B-V2	
			Yes	Ivory	NS5-MQ11-V2	
				Black	NS5-MQ11B-V2	
	5.7-inch TFT color LED backlight		No	Ivory	NS5-SQ10-V2	
				Black	NS5-SQ10B-V2	
			Yes	Ivory	NS5-SQ11-V2	
				Black	NS5-SQ11B-V2	
	5.7-inch High-luminance TFT color LED backlight		No	Ivory	NS5-TQ10-V2	
				Black	NS5-TQ10B-V2	
			Yes	Ivory	NS5-TQ11-V2	
				Black	NS5-TQ11B-V2	
NS8-V2	8.4-inch TFT LED backlight	640 × 480 dots	No	Ivory	NS8-TV00-V2	UC1, CE, N, L
				Black	NS8-TV00B-V2	
			Yes	Ivory	NS8-TV01-V2	
Black	NS8-TV01B-V2					
NS10-V2	10.4-inch TFT LED backlight	640 × 480 dots	No	Ivory	NS10-TV00-V2	UC1, CE, N, L, UL Type4
				Black	NS10-TV00B-V2	
			Yes	Ivory	NS10-TV01-V2	
Black	NS10-TV01B-V2					
NS12-V2	12.1-inch TFT LED backlight	800 × 600 dots	No	Ivory	NS12-TS00-V2	
				Black	NS12-TS00B-V2	
			Yes	Ivory	NS12-TS01-V2	
Black	NS12-TS01B-V2					
NS15-V2	15-inch TFT	1,024 × 768 dots	Yes	Silver	NS15-TX01S-V2	
				Black	NS15-TX01B-V2	
NSH5-V2 Hand-held	5.7-inch TFT	320 × 240 dots	No	Black (Emergency stop button: Red)	NSH5-SQR10B-V2	UC, CE
				Black (Stop button: Gray)	NSH5-SQG10B-V2	

NS-Runtime

Product name	Specifications	Media	Model	Standards
NS-Runtime	NS-Runtime Installer, PDF manual, hardware key (See note.)	CD	NS-NSRCL1	—
			NS-NSRCL3	
			NS-NSRCL10	

Note: A hardware key (USB dongle) is required for NS-Runtime operation.

●System Requirements

Item	Specifications
OS	Windows XP (Service Pack 3 or higher), Vista, or 7 (Support 64-bit version only for Windows 7.)
CPU	Celeron, 1.3 GHz or higher (recommended)
Memory size	HDD: 50 MB min., RAM: 512 MB min. (Windows 7: 1 GB min.). 50 MB is required for the Runtime alone. (An additional 280 MB is required if CX-Server is not already installed.)

Software

●How to select required support software for your controller

The required support software depends on the controller to connect. Please check the following table when purchasing the support software.

Item	Omron PLC System	Omron Machine Automation Controller System
Controller	CS, CJ, CP, and other series	NJ-series
Programmable Terminals	NS-series	NS-series with an Ethernet port
Software	FA Integrated Tool Package CX-One	Automation Software Sysmac Studio

●FA Integrated Tool Package CX-One

Product name	Specifications			Model	Standards
		Number of licenses	Media		
FA Integrated Tool Package CX-One Ver.4. □	<p>The CX-One is a comprehensive software package that integrates Support Software for OMRON PLCs and components.</p> <p>CX-One runs on the following OS. Windows XP (Service Pack 3 or higher), Vista or 7 Note: Except for Windows XP 64-bit version</p> <p>CX-One Version 4.□ includes CX-Designer Ver.3.□. For details, refer to the CX-One catalog (Cat. No. R134)</p>	license *1	DVD	CX-ONE-AL01-EV4	—

*1. Multi licenses are available for the CX-One (3, 10, 30, or 50 licenses).

●Automation Software Sysmac Studio

Please purchase a DVD and required number of licenses the first time you purchase the Sysmac Studio. DVDs and licenses are available individually. Each model of licenses does not include any DVD.

Product name	Specifications			Model	Standards
		Number of licenses	Media		
Sysmac Studio Standard Edition Ver.1. □	<p>The Sysmac Studio provides an integrated development environment to set up, program, debug, and maintain NJ-series Controllers and other Machine Automation Controllers, as well as EtherCAT slaves.</p> <p>Sysmac Studio runs on the following OS. Windows XP (Service Pack 3 or higher, 32-bit version) /Vista (32-bit version) /7 (32-bit/64-bit version)</p>	- (Media only)	DVD	SYSMAC-SE200D	—
	<p>The Sysmac Studio Standard Edition DVD includes support software to set up EtherNet/IP Units, DeviceNet slaves, Serial Communications Units and support software for creating screens on HMIs (CX-Designer). For details, refer to the Sysmac Integrated Catalogue (P072).</p>	1 license*	—	SYSMAC-SE201L	—

Note: To connect the NJ-series Controller, NS system version 8.5 or higher is required. CX-Designer version 3.3 or higher is also required.

* Multi licenses are available for the Sysmac Studio (3, 10, 30, or 50 licenses).





Cable

Product name	Specifications	Model	Standards	
Cable *1 	Screen transfer cable for DOS/V (CX-Designer ↔ PT)	Length: 2 m	XW2Z-S002	-
	USB-Serial Conversion cable	Length: 0.5 m	CS1W-CIF31	N
	USB relay cable	Length: 1 m	NS-USBEXT-1M	-
NSH5 Cables	RS-422A cable (loose wires + D-Sub 9-pin)	Length: 10 m	NSH5-422CW-10M	-
	RS-232C cable (loose wires + D-Sub 9-pin)	Length: 3 m	NSH5-232CW-3M	-
	RS-232C cable (loose wires + D-Sub 9-pin)	Length: 10 m	NSH5-232CW-10M	-
UL-compliant NSH5 Cable	RS-422A cable (loose wires)	Length: 10 m	NSH5-422UL-10M	CU
	RS-232C cable (loose wires + relay cable)	Length: 3 m	NSH5-232UL-3M	
	RS-232C cable (loose wires + relay cable)	Length: 10 m	NSH5-232UL-10M	
PT-to-PLC Connecting Cable *2	PT connection: 9 pins PLC connection: 9 pins	Length: 2 m	XW2Z-200T	-
		Length: 5 m	XW2Z-500T	
	PT connection: 9 pins PLC peripheral port	Length: 2 m	XW2Z-200T-2	
		Length: 5 m	XW2Z-500T-2	
NSH5 Removable Box Cable	RS-232C cable (connectors)	Length: 3 m	NSH5-232CN-3M	
		Length: 10 m	NSH5-232CN-10M	
NSH5 Removable Box	-		NSH5-AL001	
NSH5 Wall-mounting Bracket	-		NSH5-ATT02	
NSH5 Visor	-		NSH5-ATT01	

*1. Use a standard USB Type A male to Type B type male cable to connect the NS series PT to a personal computer (CX-Designer).
Use a standard USB cable to connect the NS series PT to a PictBridge-compatible printer. USB cable type depends on the printer.

*2. To connect the NS series PT to NJ series controller, using a commercially available 10/100-BASE-TX twisted-pair cable.
For detail, refer to the NS series SETUP MANUAL (Cat. No.V083).

Options

Product name	Specifications	Model	Standards	
Video Input Unit 	Inputs: 4 channels Signal type: NTSC/PAL	NS-CA001	UC1, CE	
	Input channels: 2 video channels and 1 RGB channel *1 Signal type: NTSC/PAL	NS-CA002		
Special Cable for the Console	Cable length: 2 m	F150-VKP (2 m)	-	
	Cable length: 5 m	F150-VKP (5 m)		
Controller Link Interface Unit 	For Controller Link Communications	NS-CLK21	UC1, CE	
RS-422A Adapter 	Transmission distance: 500 m total length Note: Use this model when connecting PT models without a V□ suffix. Note: PT models with the V□ suffix can also be connected.	NS-AL002	-	
	Transmission distance: 50 m total length Note: Only PT models with a suffix of V□ are connectable. Use the NS-AL002 to connect models without a V□ suffix.	CJ1W-CIF11	UC1, N, L, CE	
Sheet/Cover *2 	Anti-reflection sheets (5 surface sheets)	NS15	NS15-KBA04	-
		NS12/10	NS12-KBA04	
		NS8	NS7-KBA04	
		NS5	NT30-KBA04	
	Protective covers (5 pack) (anti-reflection coating)	NS12/10	NS12-KBA05	
		NS8	NS7-KBA05	
		NS5	NT31C-KBA05	
	Protective covers (1 cover included) (Transparent)	NS15	NS15-KBA05N	
Protective covers (5 covers included) (Transparent)	NS12/10	NS12-KBA05N		
	NS8	NS7-KBA05N		
	NS5	NT31C-KBA05N		
Attachment	NT625C/631/631C Series to NS12/10 Series	NS12-ATT01		
	NT625C/631/631C Series to NS12/NS10 Series (Black)	NS12-ATT01B		
	NT610C Series to NS12/10 Series	NS12-ATT02		
	NT620S/620C/600S Series to NS8 Series	NS8-ATT01		
	NT600M/600G/610G/612G Series to NS8 Series	NS8-ATT02		
Memory Card 	128 MB	HMC-EF183		
	256 MB	HMC-EF283		
	512 MB	HMC-EF583		
Memory Card Adapter	---	HMC-AP001	CE	
Replacement Battery	Battery life: 5 years (at 25°C)	CJ1W-BAT01	-	
Bar Code Reader	CCD handheld bar code reader (RS-232C interface)	V520-RH21-6	-	

*1. One screen cannot display two video inputs simultaneously.

*2. A Chemical-resistant Cover (NT30-KBA01) is available only for the NS5.

General Specifications

NS5/NS8/NS10/NS12/NS15

Series	NS5-V2	NS8-V2	NS10-V2	NS12-V2	NS15-V2
Rated power supply voltage	24 VDC				
Allowable voltage range	20.4 to 27.6 VDC (24 VDC ±15%)				
Power consumption	15 W max.	25 W max.			45 W max.
Ambient operating temperature	0 to 50 °C (See note on the next page.) Note: The ambient operating temperature is subject to the following restrictions according to the mounting angle. Mounting angle of 0 to 30° to the horizontal: • When no Expansion Units are mounted, the operating temperature range is 0 to 45°C. • When a Video Input Unit or a Controller Link Interface Unit is mounted, the ambient operating temperature is 0 to 35°C. Mounting angle of 30 to 90° to the horizontal: Operating temperature range of 0 to 50°C				
Storage temperature	-20 to 60 °C *1				
Ambient operating humidity	35 to 85% (0 to 40 °C), 35 to 60% (40 to 50 °C) (with no condensation)				
Operating environment	No corrosive gases.				
Noise immunity	Conforms to IEC61000-4-4, 2 kV (power lines).				
Vibration resistance (during operation)	10 to 57 Hz, 0.075 mm amplitude, 57 to 150 Hz, 9.8 m/s ² 30 min each in X, Y, and Z directions				5 to 8.4 Hz, 3.5 mm single amplitude, 8.4 to 150 Hz, 9.8 m/s ² 10 min times each in X, Y, and Z directions
Shock resistance (during operation)	147 m/s ² 3 times each in direction of X, Y, and Z				
Weight	1.0 kg max.	2.0 kg max.	2.3 kg max.	2.5 kg max.	4.2 kg max.
Degree of protection	Front operating panel: Equivalent to IP65 oil-proof type and NEMA4 UL type 4. *2 Note: May not be applicable in locations with long-term exposure to oil.				
Ground	Ground to 100 Ω or less.				
Battery life	5 years (at 25 °C): Replace battery within 5 days after the battery runs low (indicator lights orange).				
Applicable standards	Certified for conformance to UL 508, UL 1604, EMC Directive, NK, and LR Standards.				

*1. Operate the PT within the temperature and humidity ranges shown in the right diagram.

*2. Support for NS5, NS10, NS12 and NS15.

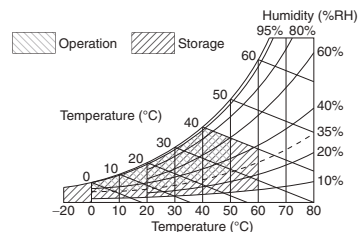

NSH5 Hand-held PT

Series	NSH5-V2	
Type	5.7-inch Color TFT (Hand-held Version)	
Case colour	black	
Built-in Ethernet port	No	
Model	NSH5-SQR10B-V2 (Emergency stop button: Red)	NSH5-SQG10B-V2 (Stop button: Gray)
Rated power supply voltage	24 VDC	
Allowable voltage range	20.4 to 27.6 VDC (24 VDC ±15%)	
Power consumption	10 W max.	
Ambient operating temperature	0 to 40°C	
Storage temperature	-20 to 60°C	
Ambient operating humidity	35% to 85% (0 to 40°C) with no condensation	
Operating environment	No corrosive gases.	
Noise immunity	Common mode: 1,000 Vp-p (between power supply terminals and panel) Normal mode: 300 Vp-p Pulse width: 100 ns to 1 μs, Rise time: 1-ns pulse	
Vibration resistance (during operation)	10 to 57 Hz, 0.075 mm amplitude, 57 to 150 Hz, 9.8 m/s ² 30 min each in X, Y, and Z directions	
Shock resistance (during operation)	147 m/s ² 3 times each in direction of X, Y, and Z	
Weight	1 kg max.	
Degree of protection	Equivalent to IP65.	
Ground	Ground to 100 Ω or less.	
Battery life	5 years (at 25°C): Replace battery within 5 days after the battery runs low (indicator lights orange).	
Applicable standards	Certified for conformance to UL 508, EMC Directive, and EN 60204-1.	

Austria

Tel: +43 (0) 2236 377 800
www.industrial.omron.at

Belgium

Tel: +32 (0) 2 466 24 80
www.industrial.omron.be

Czech Republic

Tel: +420 234 602 602
www.industrial.omron.cz

Denmark

Tel: +45 43 44 00 11
www.industrial.omron.dk

Finland

Tel: +358 (0) 207 464 200
www.industrial.omron.fi

France

Tel: +33 (0) 1 56 63 70 00
www.industrial.omron.fr

Germany

Tel: +49 (0) 2173 680 00
www.industrial.omron.de

Hungary

Tel: +36 1 399 30 50
www.industrial.omron.hu

Italy

Tel: +39 02 326 81
www.industrial.omron.it

Netherlands

Tel: +31 (0) 23 568 11 00
www.industrial.omron.nl

Norway

Tel: +47 (0) 22 65 75 00
www.industrial.omron.no

Poland

Tel: +48 22 458 66 66
www.industrial.omron.pl

Portugal

Tel: +351 21 942 94 00
www.industrial.omron.pt

Russia

Tel: +7 495 648 94 50
www.industrial.omron.ru

South Africa

Tel: +27 (0)11 579 2600
www.industrial.omron.co.za

Spain

Tel: +34 913 777 900
www.industrial.omron.es

Sweden

Tel: +46 (0) 8 632 35 00
www.industrial.omron.se

Switzerland

Tel: +41 (0) 41 748 13 13
www.industrial.omron.ch

Turkey

Tel: +90 212 467 30 00
www.industrial.omron.com.tr

United Kingdom

Tel: +44 (0) 870 752 08 61
www.industrial.omron.co.uk

More Omron representatives
www.industrial.omron.eu

Automation Systems

- Programmable logic controllers (PLC) • Human machine interfaces (HMI) • Remote I/O
- Industrial PC's • Software

Motion & Drives

- Motion controllers • Servo systems • Inverters • Robots

Control Components

- Temperature controllers • Power supplies • Timers • Counters • Programmable relays
- Digital panel indicators • Electromechanical relays • Monitoring products • Solid-state relays
- Limit switches • Pushbutton switches • Low voltage switch gear

Sensing & Safety

- Photoelectric sensors • Inductive sensors • Capacitive & pressure sensors
- Cable connectors • Displacement & width-measuring sensors • Vision systems
- Safety networks • Safety sensors • Safety units/relay units • Safety door/guard lock switches