

MOTOGEN

TECHNICAL SPECIFICATIONS

PARAMETERS	Value
Motor type	132M2B
Frame size	132M
Output power (KW/HP)	7.5/10
Rated voltage D/Y-(V)	380/660
Rated Speed (RPM)	2905
Rated current D/Y-(A)	15.2/8.8
Rated torque (N m)	24.65
Efficiency (%)	88.1
Power factor (cos phi)	0.85
Starting current/Rated current	7.2
Starting torque/Rated torque	2.8
Breakdown torque/Rated torque	3.2
Moment of inertia (Kg*m ²)	0.014361
Weight (Kg)	44.9
Color	Blue-RAL5001
Body	Cast Iron
Stator winding wire material	copper
Rotor winding material	aluminium
Driven end bearing	6308-2Z
Non-driven end bearing	6308-2Z
Insulation class	F
Thermal Class	B
IP درجه حفاظت	65

الکتروموتور 132M2B 7.5-3000 65F 380/660 چدنی (132M2B)
 فنج B3

سایز فریم 100-160

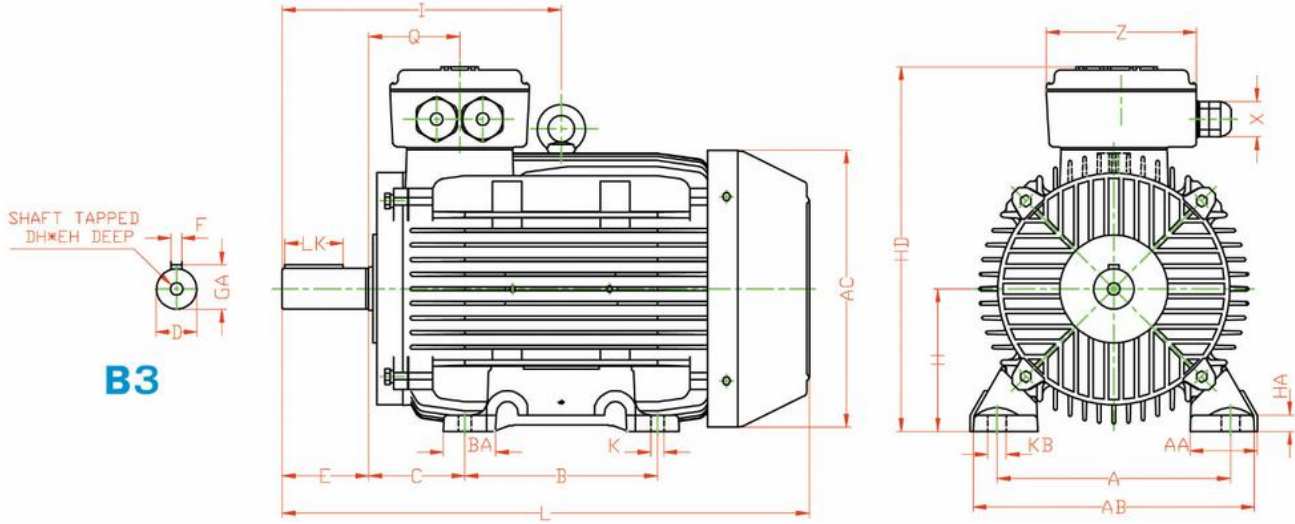

B	BA	K	KB	AB	A	AA	HA	AC	Z	Q	I	L	E	EH	DH	GA	LK	F	D
178	48.5	12	17	260	216	62	15	256.5	139	84	258	487.5	80	28	M12	41	56	10	38

X	T	S	P	N	M	LA	AD	HD	H	C
Pg21	-	-	-	-	-	-	-	337.5	132	89