

MOTOGEN

TECHNICAL SPECIFICATIONS

PARAMETERS	Value
Motor type	CR71M2C
Frame size	71M
Output power (KW/HP)	0.75/1
Rated voltage -(V)	220
Rated Speed (RPM)	2814
Rated current -(A)	4.7
Rated torque (N m)	2.5
Efficiency (%)	74
Power factor (cos phi)	0.98
Starting current/Rated current	2.9
Starting torque/Rated torque	0.4
Breakdown torque/Rated torque	1.6
Color	Blue-RAL5001
Body	Aluminium
Rotor winding material	Aluminium
Stator winding wire material	Copper
(m) Height	45
Flow rate (m ² /s)	0.3
Driven end bearing	6202-2Z
Non-driven end bearing	6202-2Z
Flow rate (m ³ /h)	0.3
Run Capacitor (μF)	25
Run Capacitor Voltage (V)	400
Insulation class	F
Thermal Class	B
درجه حفاظت IP	44

الکترو پمپ خانگی جتی 0.75 CAM100 CR71M2C (پمپ آب خانگی)
فلنج B34

سایز فریم 56-112

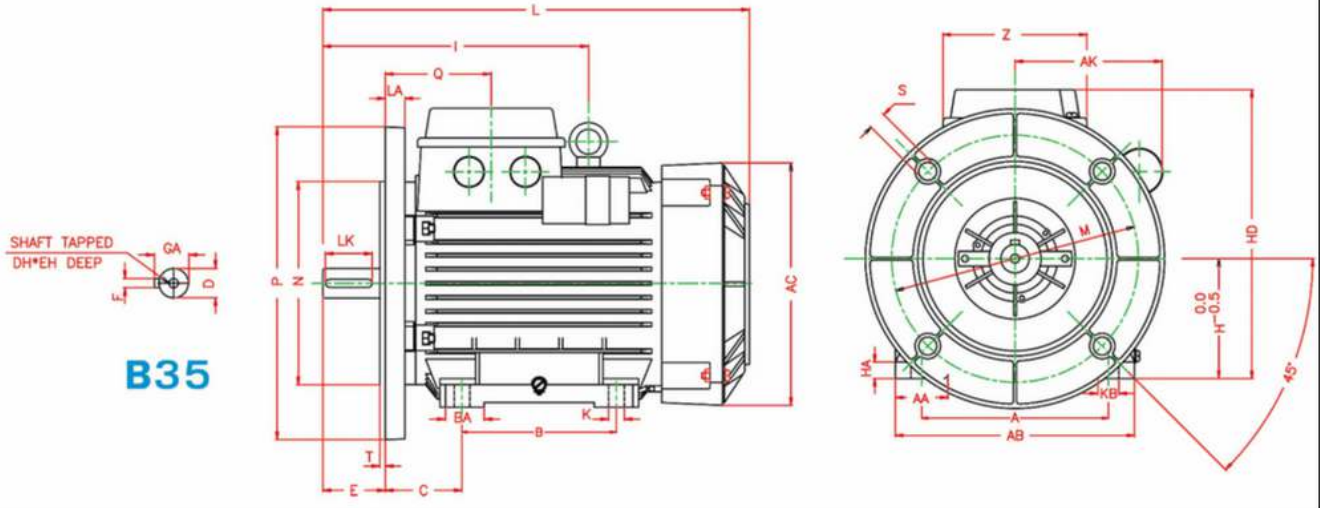

C	B	BA	K	KB	AB	A	AA	HA	AC	Z	Q	L	E	EH	DH	GA	LK	F	D
45	90	18	7	10	140	112	28	11	138	76	58	241	30	-	-	16	18	5	14

FLANGE SYM (DIN)	FLANGE SYM (IEC)	T	S	P	N	M	LA	AK	HD	H
A160	FF130	3.5	10	160	110	130	10	110	175	71