

# MOTOGEN

## TECHNICAL SPECIFICATIONS

PARAMETERS	Value
Motor type	CR90L2B
Frame size	90
Output power (KW/HP)	2.2/3.0
Rated voltage D/Y-(V)	220
Rated Speed (RPM)	2840
Rated current D/Y-(A)	12.6
Rated torque (N m)	7.4
Efficiency (%)	83.2
Power factor (cos phi)	0.98
Starting current/Rated current	3.7
Starting torque/Rated torque	0.4
Breakdown torque/Rated torque	1.6
Moment of inertia (Kg*m2)	0.001816
Color	RAL7024 GRAY
Body	aluminium
Stator winding wire material	copper
Rotor winding material	aluminium
Driven end bearing	6205-2Z
Non-driven end bearing	6205-2Z
Insulation class	F
Thermal Class	B
IP درجه حفاظت	54

الکتروموتور (CR90L2B) 2.2-3000 54F  
فلنج B3

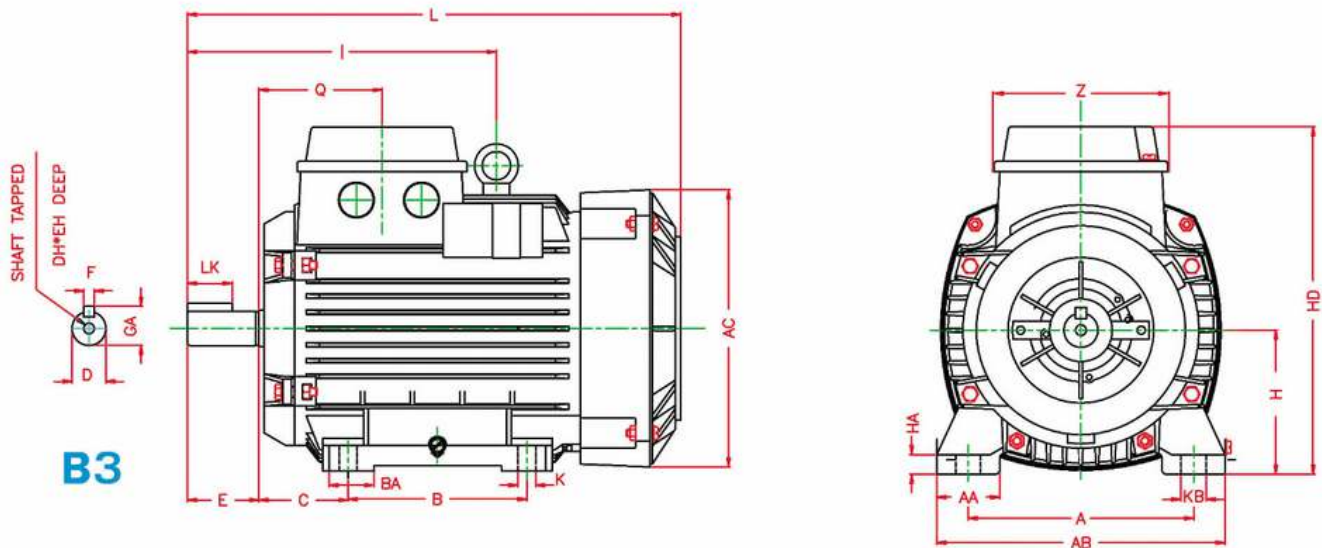

D F LK GA DH E H E L Q Z AC HA AA A AB KB K BA B C  
 24 8 32 27 M8 19 50 325 70.5 96 175 12 43.3 140 182 14 10 30 125 56

H HD AK LA M N P S T FLANGE SYM (IEC) FLANGE SYM (DIN)  
 90 215 137 12 165 130 200 12 3.5 FF165 A200