

SITRANS FCT010

Overview



FCT010 is based on the latest developments within digital signal processing technology – engineered for high measuring performance, fast response to step changes in flow, fast dosing applications, high immunity against process noise, easy to install commission and maintain.

The FCT010 transmitter delivers true multi-parameter measurements i.e. massflow, volumeflow, standard volumeflow, density, temperature. All with a single Modbus connection.

The FCT010 IP67 transmitter is compact mounted with all sensors of type FCS300, FCS400, MASS 2100 DI 3, DI 6, DI 15.

For MASS 2100 DI 1.5 to DI 15 and FC300 DN 4 an analogue connection is available for a remote FCT010 solution.

Benefits

Flow calculation and measurement

Dedicated mass flow calculation with DSP technology

- Fast dosing and flow step response with maximum 10 ms response time
- 100 Hz update rate to all outputs
- Independent low flow cut-off settings for mass and volume flowrates
- Automatic zero-point adjustment on command from discrete input or host system

Operation

- User-configurable settings over SIMATIC PDM

Alarms and safety

- Advanced diagnosis and service menu enhances troubleshooting and meter validation
- Configurable upper and lower alarm and warning limits for all process values
- Alarm handling can be selected between Siemens and NAMUR standard configurations

Outputs and control

- Single channel Modbus RTU output
- Individually configurable for massflow, volumeflow, standard volumeflow, density, temperature
- One Totalizer (data not secured by power failure)

Approvals and certificates

The FCT010 coriolis flowmeter program was designed from the ground up to comply with or exceed the requirements of international standards and regulations.

Application

SITRANS FCT010 transmitters are suitable for applications within the entire process industry where there is a demand for accurate flow measurement. The meter is capable of measuring both liquid and gas flow.

Coriolis flowmeters can be applied in all industries, such as:

- Chemical & Pharma: detergents, bulk chemicals, acids, alkalis, paint mixing systems, solvents and resins, pharmaceuticals, blood products, vaccines, insulin production
- Food & Beverage: dairy products, beer, wine, soft drinks, CO₂ dosing, CIP/SIP-liquids, mixture recipe control
- Automotive: fuel injection nozzle & pump testing, filling of AC units, engine consumption
- Oil & Gas applications e.g. test separators
- Hydrocarbon processing: oil refining, derivatives manufacturing, polymerisation
- Water & Waste Water: dosing of chemicals for water treatment

The Modbus communication mean that all of the process information can be read either instantaneously (10 ms update) or periodically as plant operation requires.

Design

The transmitter SITRANS FCT010 is designed in an IP67/NEMA 4X aluminum enclosure with corrosion resistant coating.

It is compact mounted with the following sensors:

- FCS300 DN 15, DN 25, DN 50, DN 80, DN 100, DN 150
- FCS400 DN 15, DN 25 and DN 50
- MASS 2100 DI 3, DI 6, DI 15

It can be remote mounted with the following sensors:

- MASS 2100 DI 1.5, DI 3, DI 6, DI 15

- FC300 DN 4

FCT010 is available with Modbus RS 485 RTU as standard.

SensorFlash

SensorFlash is a standard, 4 GByte micro SD card with the ability to be updated by PC. It is supplied with each sensor with the complete set of certification documents including calibration report. Material, pressure test, factory conformance certificates are optional at ordering.

The Siemens SensorFlash memory unit for the FCT010 only has the function of documentation including a parameter backup and a FW bundle. The Sensor Flash is not mounted into the FCT010 and will not have the extra features as the FCT030 transmitter has.

- Storing of alarm history log
- Storing of parameter change log

Function

The following functions are available:

- Mass flowrate, volume flowrate, density, process temperature
- Single Modbus RTU I/O
- Low flow cut-off, adjustable
- Density cut-off or empty pipe cut-off, adjustable
- Flow direction adjustable
- Alarm system consisting of alarm-log, alarm pending menu
- Uni/bidirectional flow measurement
- Flowrate outputs are freely configurable between maximum negative and maximum positive flows according to the sensor capacity
- Process noise filter for optimization of measurement performance under non-ideal application conditions. 5-stage pumping filter compensates for flow fluctuations caused by e.g. single acting piston pumps
- Full service menu for effective and straight forward application and meter troubleshooting
- Aerated flow filtering system, for advanced filtering of fluids with gas or air bubbles

Technical specifications

SITRANS FCT010

Number of process variables	5
Measurement of	<ul style="list-style-type: none"> • Mass flow • Volume flow • Density • Process media temperature • Standard volume flow
I/O	Modbus RTU
Galvanic isolation	All inputs and outputs are galvanically isolated, isolation voltage 500 V
Cut-off	
Low-flow	0 ... 9.9 % of maximum flow
Limit function	Mass flow, volume flow, density, sensor temperature
Totalizer	One eight-digit counters for forward, or reverse flow - data recovery not protected at power loss
Zero point adjustment	Via SIMATIC PDM
Ambient temperature	
Operation	
• Transmitter	-40 ... +60 °C (-40 ... +140 °F) (humidity max. 95 %)
Storage	
• Transmitter	-40 ... +70 °C (-40 ... +158 °F) (humidity max. 95 %)
Communication Ch1	Modbus RS 485 RTU
Enclosure	
Material	Aluminum corrosion Class C4
Rating	IP67/NEMA 4X to EN/IEC 60529 (1 mH ₂ O for 30 min.)
Mechanical load	18 ... 1000 Hz random, 3.17 g RMS, in all directions, to IEC 68-02-36
Supply voltage	
Supply	12 ... 27 V DC Ex d: 12-24 V DC Intrinsic safe: Ui: 20 V, Ii: 484 mA, Pi: 2.3 W, Li: 0.6 uH, Ci: 1.9 nF
Fluctuation	No limit
Power consumption	1.1 W
EMC performance	
Emission	EN 55011/CISPR-11 (Class A)
Immunity	EN/IEC 61236-1 (Industry)

SITRANS FCT010

NAMUR	Within the value limits according to "General requirements" with error criteria A in accordance with NE 21
Environment	
Environmental conditions acc. to IEC/EN/UL 61010-1	<ul style="list-style-type: none">• Altitude up to 2000 m• Pollution degree 2
Maintenance	The flowmeter has a built-in error log/pending menu which should be inspected on a regular basis.
Cable glands	M12 connector Cable glands are available in nylon, nickel plated brass or stainless steel (316L/W1.4404) in the following dimensions: <ul style="list-style-type: none">• 1 × M20• 1 × ½" NPT
Digital cable connection	Standard industrial signal cable up to 75 m long with 2 × screened pairs or 4-wire overall screen can be laid between the sensor and transmitter. Siemens offers cables in a selection of pre-cut lengths and prepared for either gland or plug connection.
Analog cable connection (MASS 2100/FC300)	Standard industrial cable up to 15 m distance between sensor and transmitter. PVC insulated 5 × 2 × Ø 0.34 mm, twisted and screened in pairs, temperature range -20 ... +105 °C
Approvals	
Hazardous area	FCT010 can be installed in zone 1 for gas and zone 21 for dust (dust: depending on sensor type) and Class 1 Div 1/ Zone 1 <ul style="list-style-type: none">• ATEX, IECEx, cCSAus (Class 1 Div 1), EAC Ex, cCSAus Zone 1, NEPSI Zone 1
Certificates	
CE mark	<ul style="list-style-type: none">• Pressure equipment• Low voltage directive• WEEE• RoHS
Regional certifications	<ul style="list-style-type: none">• C-TICK (Australia and New Zealand EMC)• EAC (Belarus, Armenia, Kazakhstan, Russia)• KCC (South Korea) (in preparation)

Dimensional drawings

Dimension for the FCT010 remote mounted (for analog cable connections for MASS 2100 / FC300 DN4)

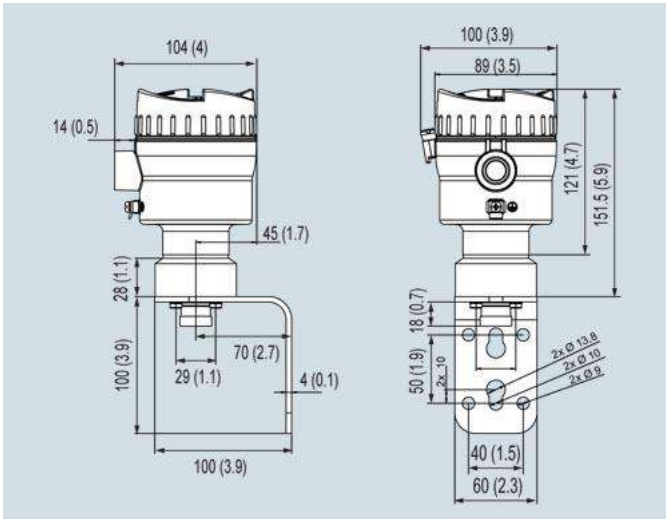

SITRANS FCT010, dimensions in mm (inch)